



ASSEMBLY INSTRUCTIONS
COASTER FINE FURNITURE



Fine Furniture for every stage of life

107072
Side Chair

ITEM: 107072

ASSEMBLY INSTRUCTIONS



ASSEMBLY TIPS:

1. Remove hardware from box and sort by size.
2. Please check to see that all hardware and parts are present prior to start of assembly.
3. Please follow attached instructions in the same sequence as numbered to assure fast & easy assembly.



WARNING!



1. Don't attempt to repair or modify parts that are broken or defective. Please contact the store immediately.
2. This product is for home use only and not intended for commercial establishments.







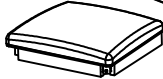

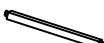
ASSEMBLY TIME

15 MINUTES

PARTS IDENTIFICATION

A	BACK FRAME		1PC
B	SEAT CUSHION WITH FRAME		1PC
C	LEFT FRONT LEG		1PC
D	RIGHT FRONT LEG		1PC
E	STRETCHER		2PCS

HARDWARE IDENTIFICATION

1	LONG BOLT (1/4" x 75mm - BLK)		4PCS
2	MEDIUM BOLT (1/4" x 50mm - BLK)		4PCS
3	SHORT BOLT (1/4" x 35mm - BLK)		2PCS
4	LOCK WASHER (1/4" x 13mm - BLK)		10PCS
5	FLAT WASHER (1/4" x 19mm - BLK)		10PCS
6	ALLEN WRENCH (4mm x 64mm - BLK)		1PC
7	FLAT HEAD SCREW (4mm x 40mm - BLK)		4PCS

NOTE:

Quantities shown are for one chair.

Phillips head screw driver is required in the assembly process; however, manufacturer does not provide this item.

ITEM: **107072**
ASSEMBLY INSTRUCTIONS
STEP 1

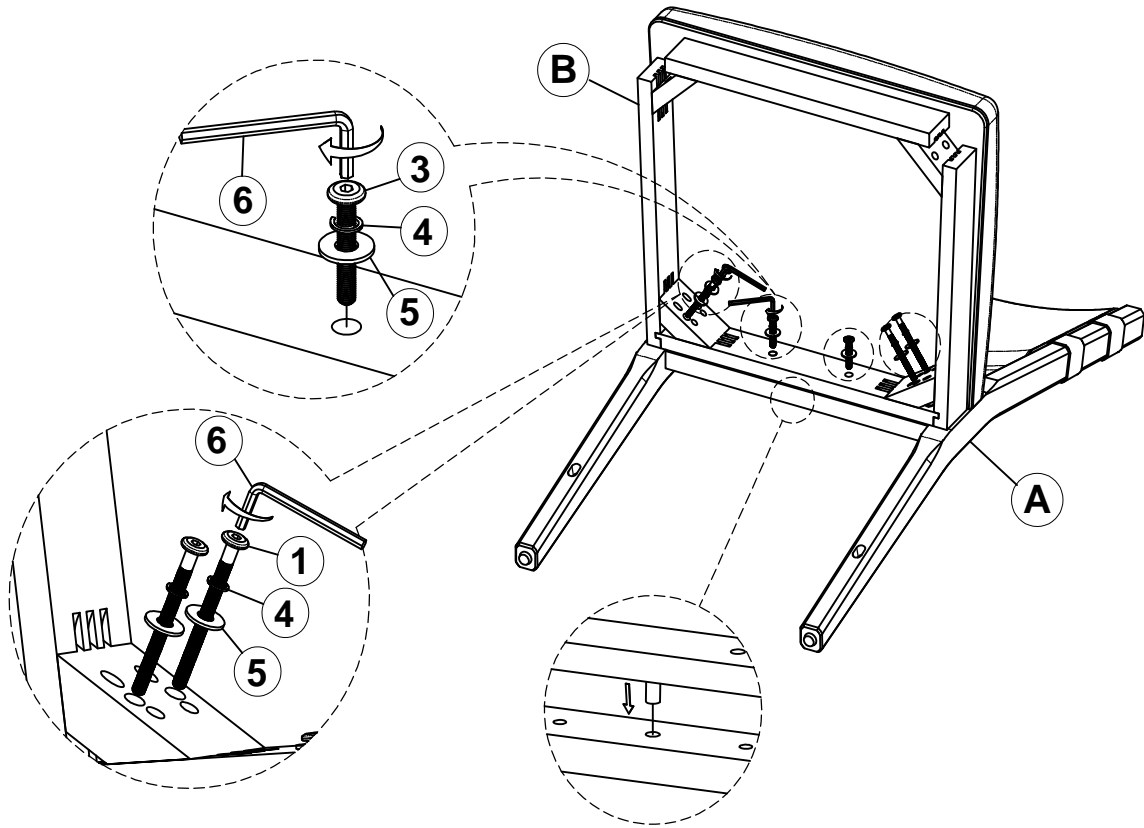

STEP 2

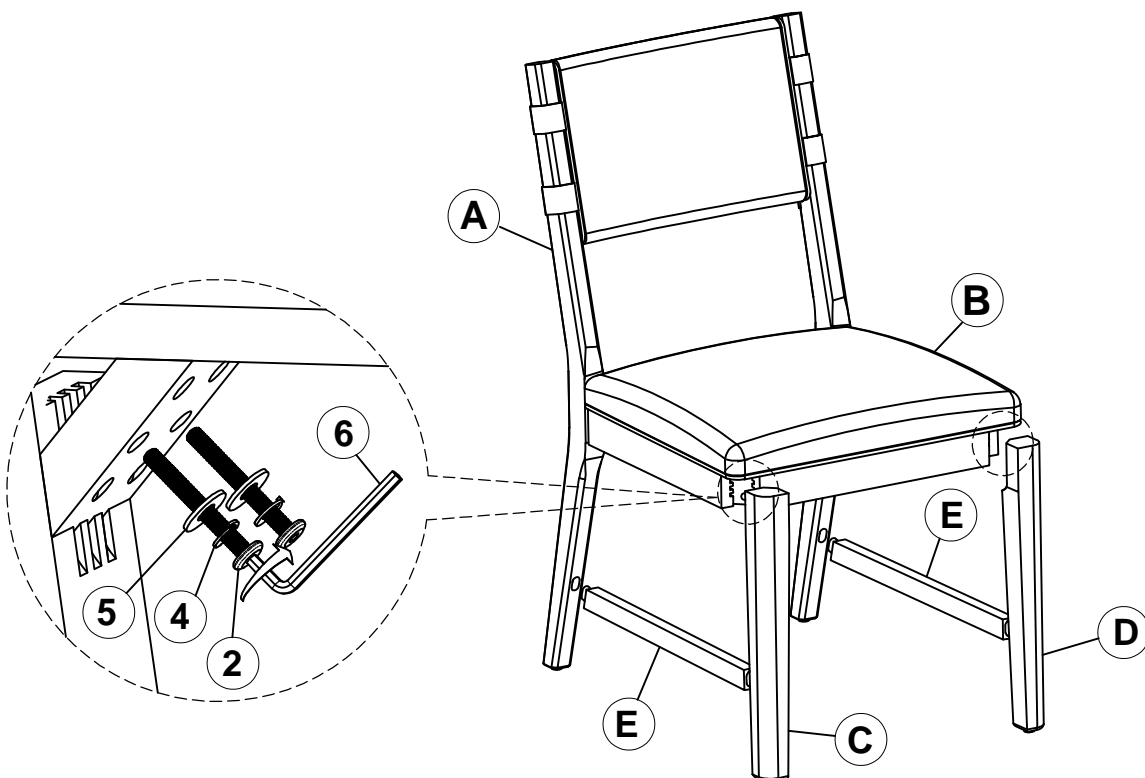

ITEM: **107072**
ASSEMBLY INSTRUCTIONS
STEP 3

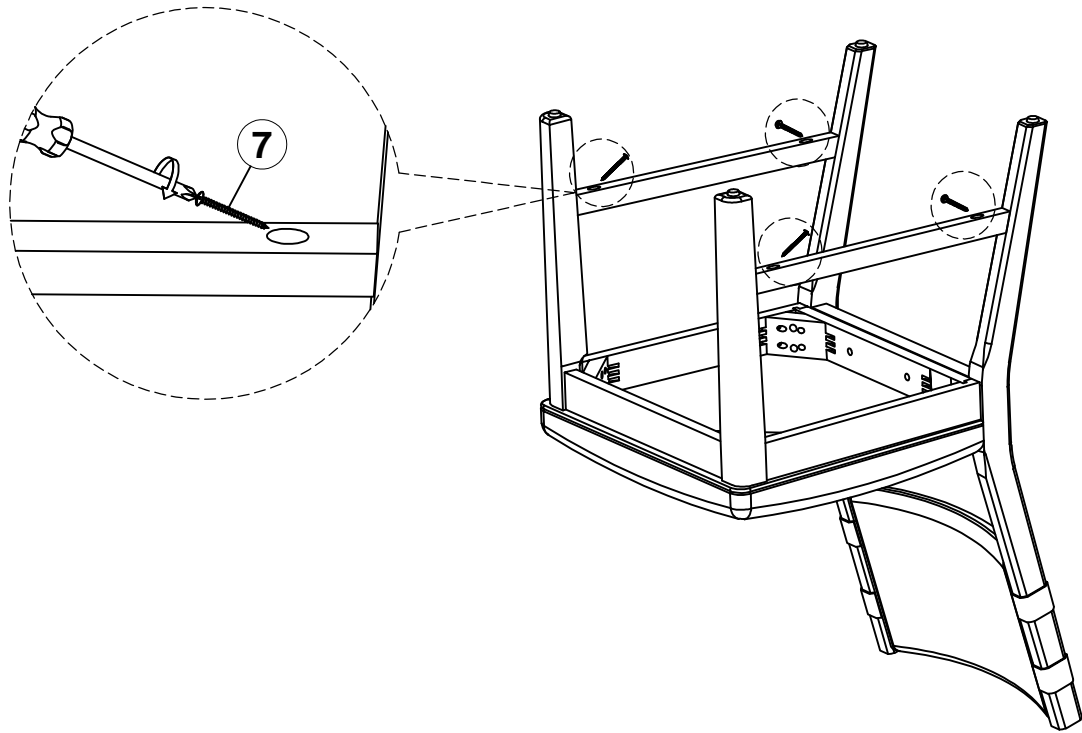

STEP 4
COMPLETE

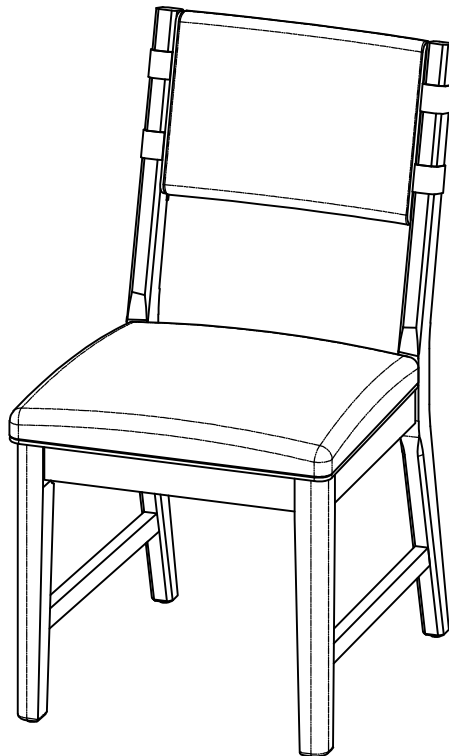

ITEM: 107072

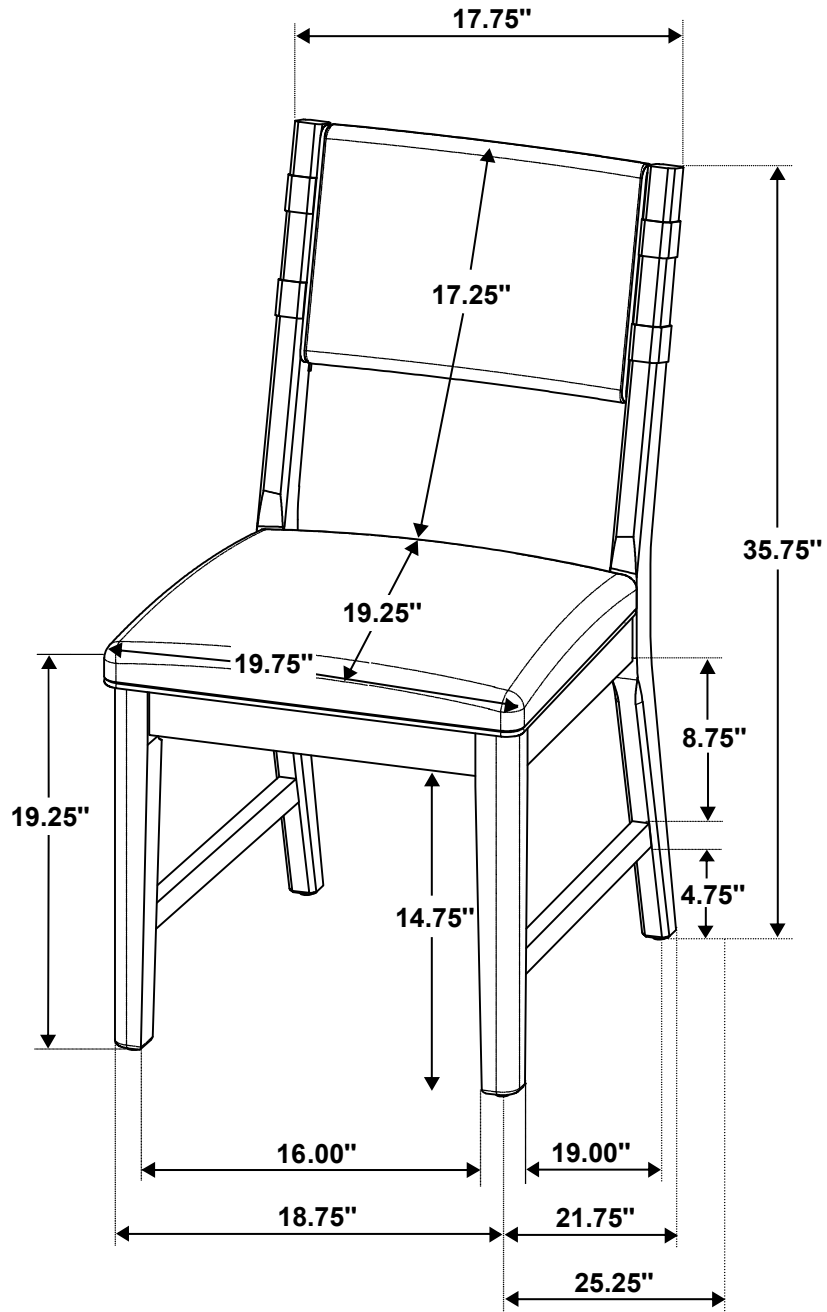

Note: Dimension tolerance $\pm 5\%$