



ASSEMBLY INSTRUCTIONS
COASTER FINE FURNITURE



Fine Furniture for every stage of life

108540 (B1&B2)
Dining Table

ITEM: 108540(B1&B2)



ASSEMBLY INSTRUCTIONS

ASSEMBLY TIPS:

1. Remove hardware from box and sort by size.
2. Please check to see that all hardware and parts are present prior to start of assembly.
3. Please follow attached instructions in the same sequence as numbered to assure fast & easy assembly.



WARNING!

1. Don't attempt to repair or modify parts that are broken or defective. Please contact the store immediately.
2. This product is for home use only and not intended for commercial establishments.



ASSEMBLY TIME

15 MINUTES

PARTS IDENTIFICATION

B1 (BOX 1)

A TOP

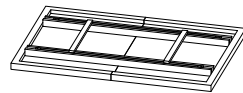

1PC

B LEAF



1PC

C CROSSBAR



1PC

D APRON



2PCS

B2 (BOX 2)

E LEG FRAME

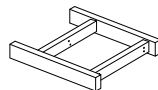

2PCS

HARDWARE IDENTIFICATION

Z-B1 (BOX 1) - HARDWARE PACK IS LOCATED IN 108540(B1)

1 BOLT
(Ø5/16" x 1-1/2" - RBW)

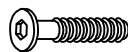

12PCS

2 THREADED BOLT
(Ø5/16" x 3" - RBW)



4PCS

3 LOCK WASHER
(Ø5/16" - RBW)



12PCS

4 FLAT WASHER
(Ø5/16" - RBW)



12PCS

5 HEX NUT
(Ø5/16" - RBW)



4PCS

6 HALF ROUND NUT
(Ø5/16" - RBW)



4PCS

7 ALLEN WRENCH
(4MM - RBW)



1PC

8 WRENCH
(RBW)



1PC

ITEM: **108540(B1&B2)**

ASSEMBLY INSTRUCTIONS

STEP 1

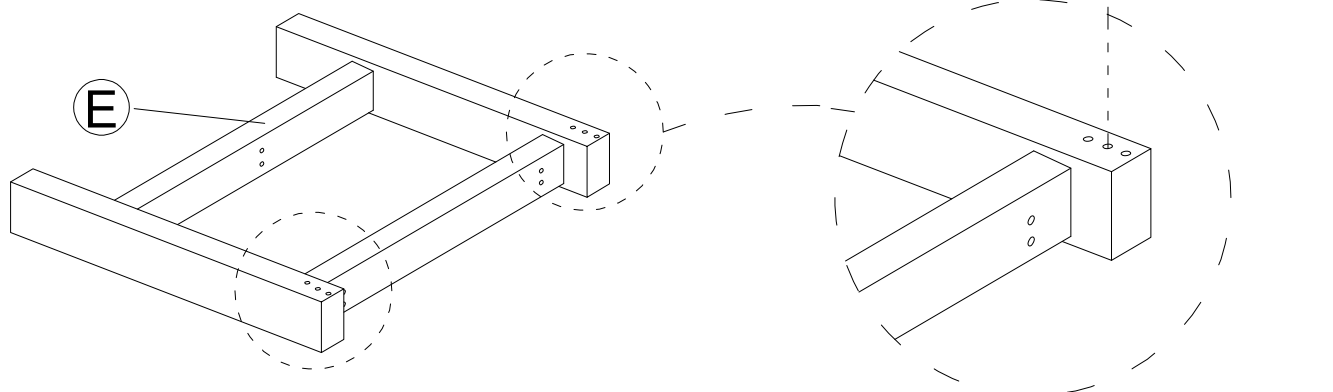

STEP 2

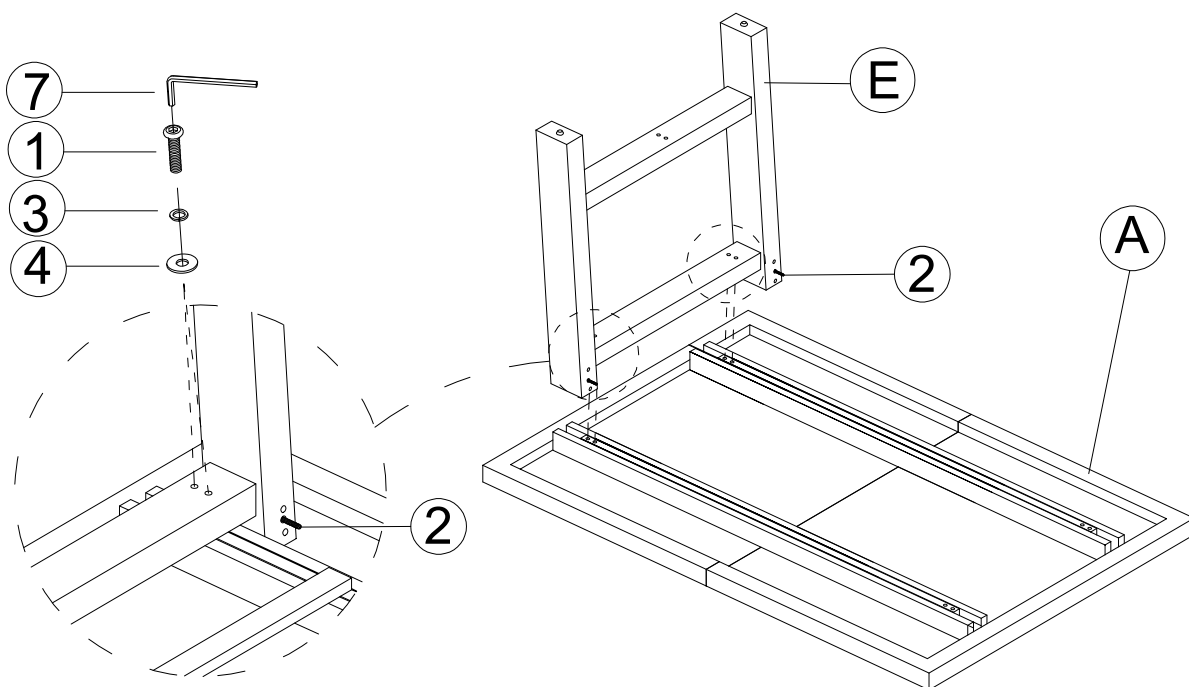

STEP 3

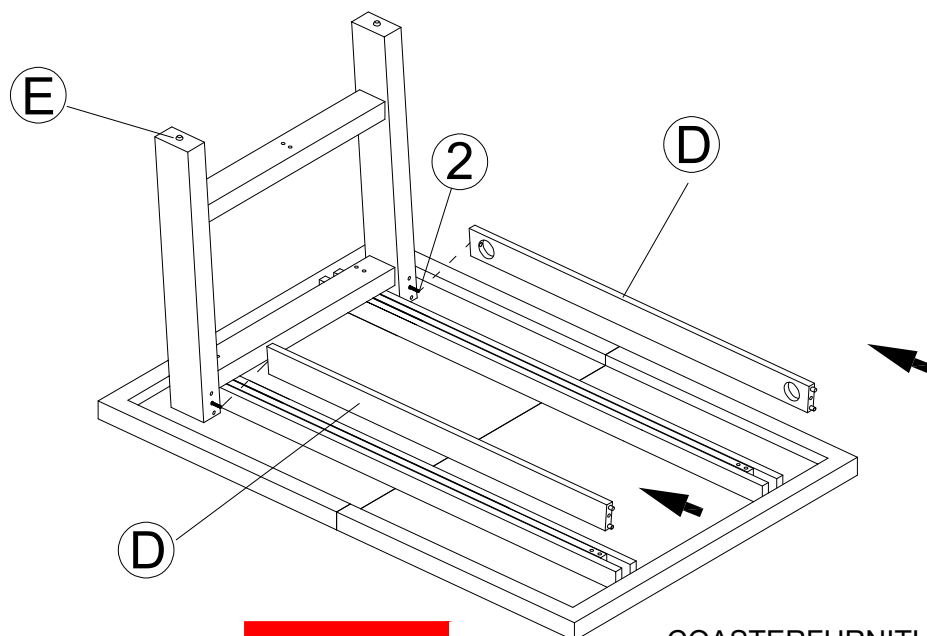

ITEM: 108540(B1&B2)

ASSEMBLY INSTRUCTIONS

STEP 4

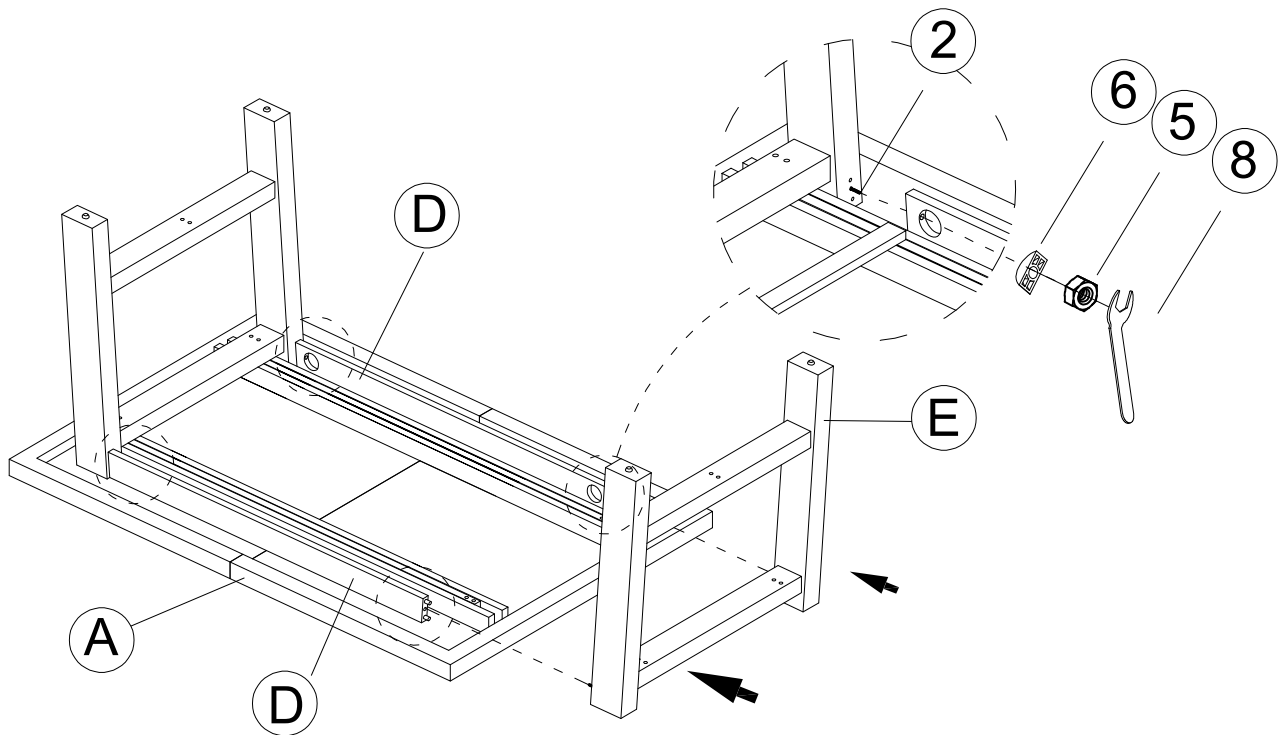

STEP 5

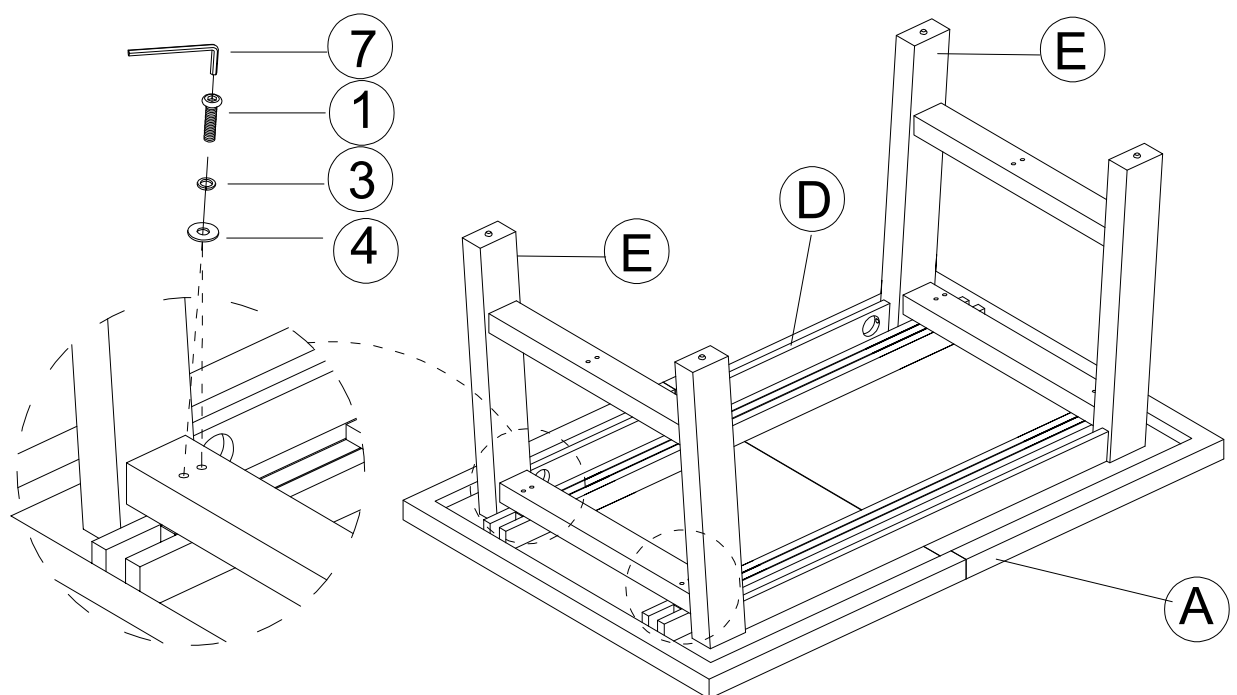

ITEM: **108540(B1&B2)**

ASSEMBLY INSTRUCTIONS



STEP 6

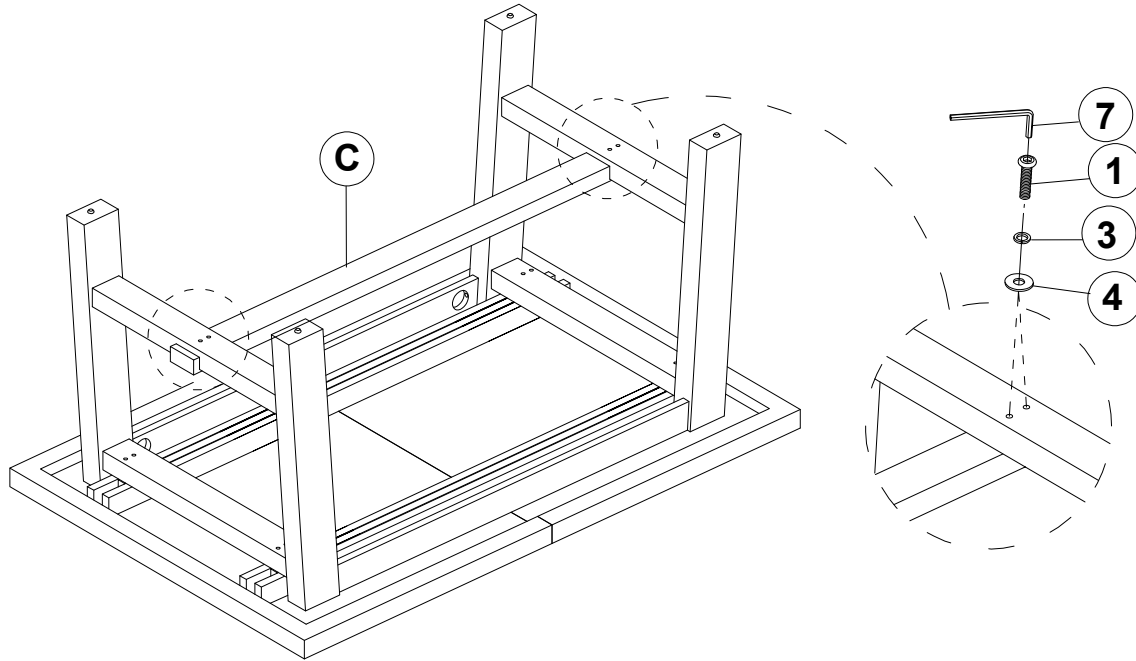

STEP 7
COMPLETE

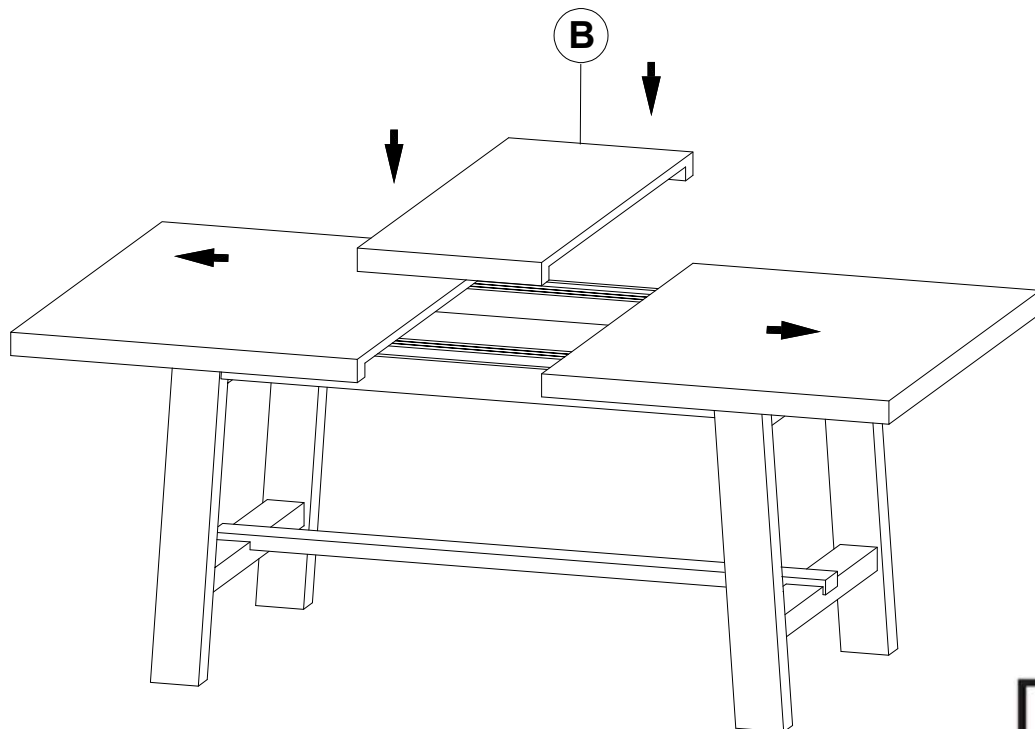

ITEM: 108540(B1&B2)

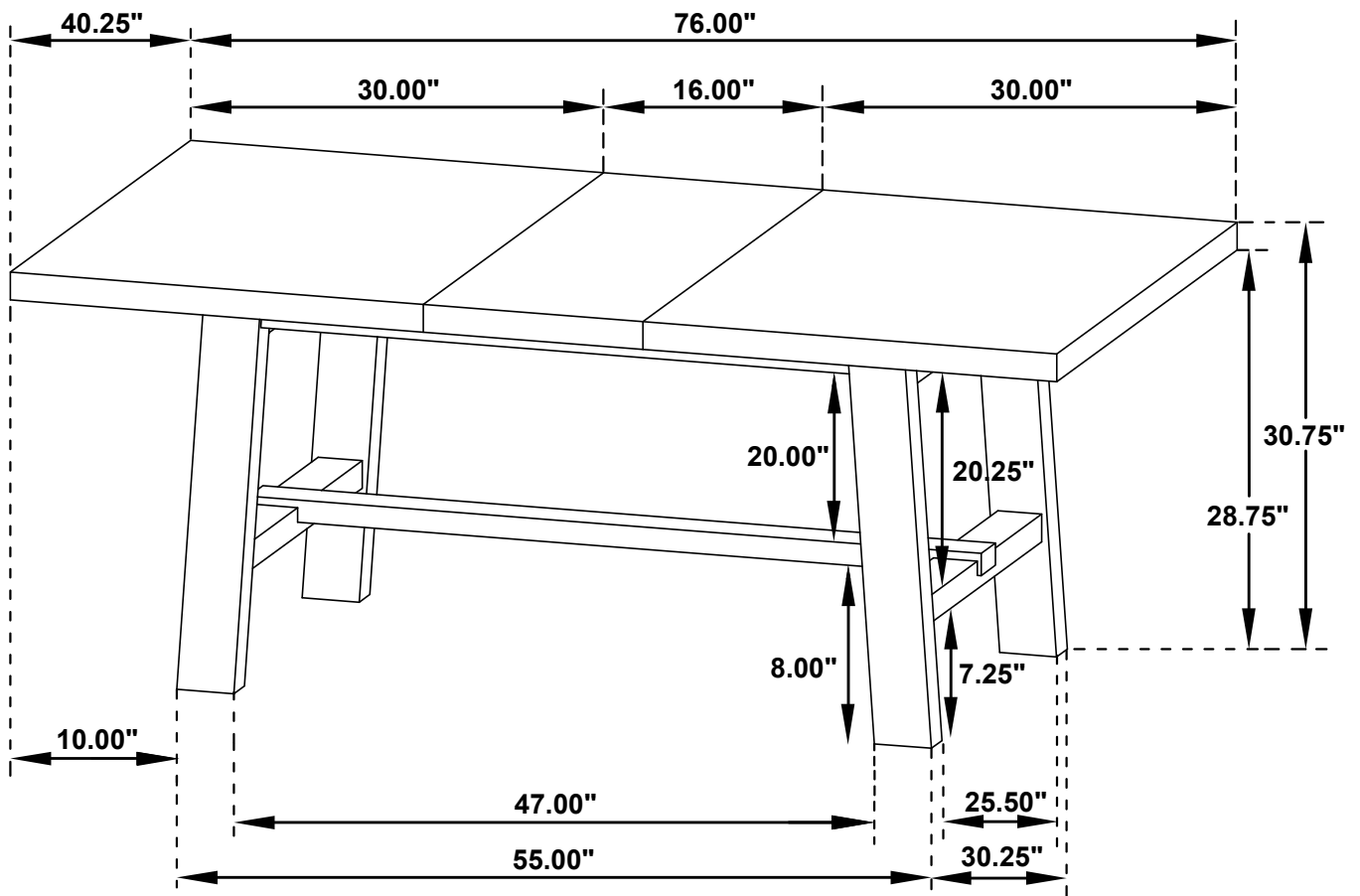

Note: Dimension tolerance $\pm 5\%$



ASSEMBLY INSTRUCTIONS
COASTER FINE FURNITURE



Fine Furniture for every stage of life

108542
Side Chair

ITEM: 108542



ASSEMBLY INSTRUCTIONS

ASSEMBLY TIPS:

1. Remove hardware from box and sort by size.
2. Please check to see that all hardware and parts are present prior to start of assembly.
3. Please follow attached instructions in the same sequence as numbered to assure fast & easy assembly.



WARNING!

1. Don't attempt to repair or modify parts that are broken or defective. Please contact the store immediately.
2. This product is for home use only and not intended for commercial establishments.



ASSEMBLY TIME

15 MINUTES

PARTS IDENTIFICATION

A BACK FRAME

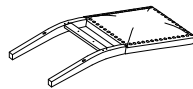

1PC

B SEAT CUSHION WITH FRAME

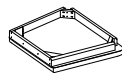

1PC

C LEFT FRONT LEG

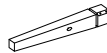

1PC

D RIGHT FRONT LEG

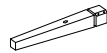

1PC

E LEFT SIDE STRETCHER



1PC

F RIGHT SIDE STRETCHER

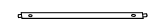

1PC

G MIDDLE STRETCHER



1PC

HARDWARE IDENTIFICATION

1 LONG BOLT
(Ø1/4" x 3" - RBW)



4PCS

2 MEDIUM BOLT
(Ø1/4" x 2" - RBW)



4PCS

3 SHORT BOLT
(Ø1/4" x 1-1/2" - RBW)



2PCS

4 LOCK WASHER
(Ø1/4" - RBW)



10PCS

5 FLAT WASHER
(Ø1/4" - RBW)



10PCS

6 ALLEN WRENCH
(4MM - RBW)



1PC

7 PAN HEAD SCREW
(#8MM x 1-1/2" - RBW)

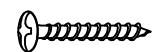

6PCS

NOTE:

Quantities shown are for one chair.

Phillips head screw driver is required in the assembly process; however, manufacturer does not provide this item.

ITEM: 108542

ASSEMBLY INSTRUCTIONS

STEP 1

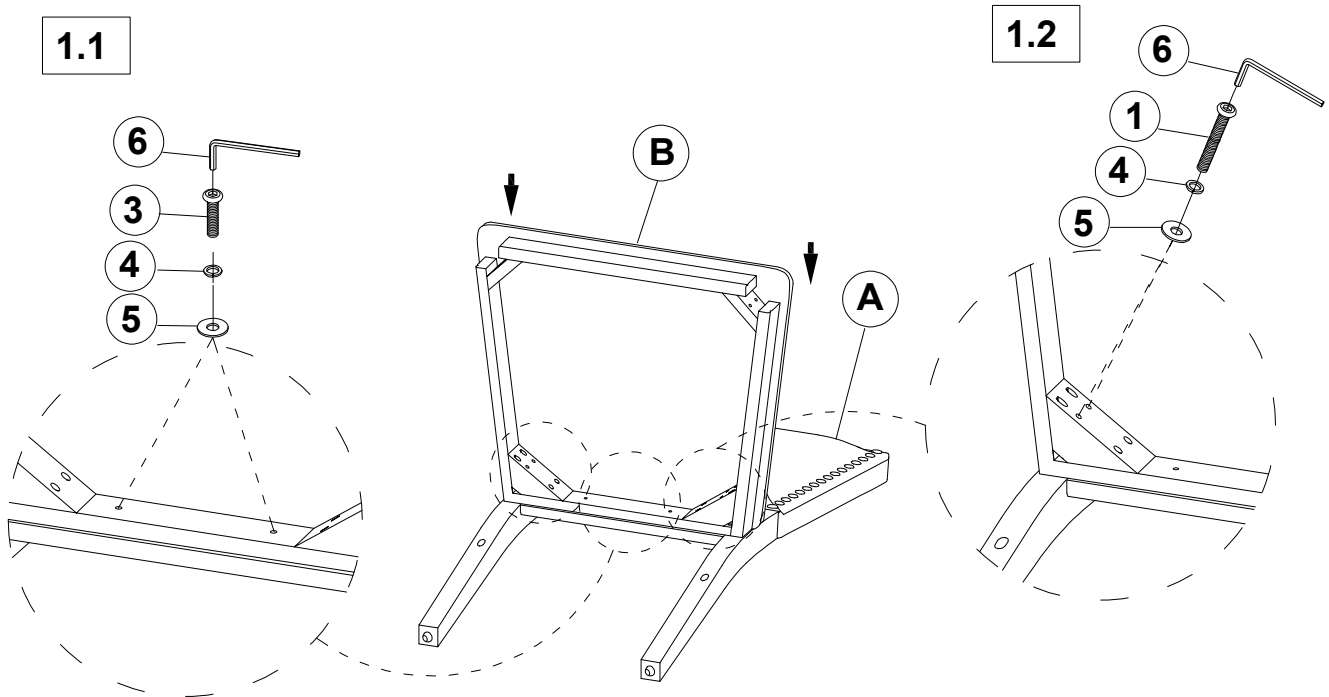

STEP 2

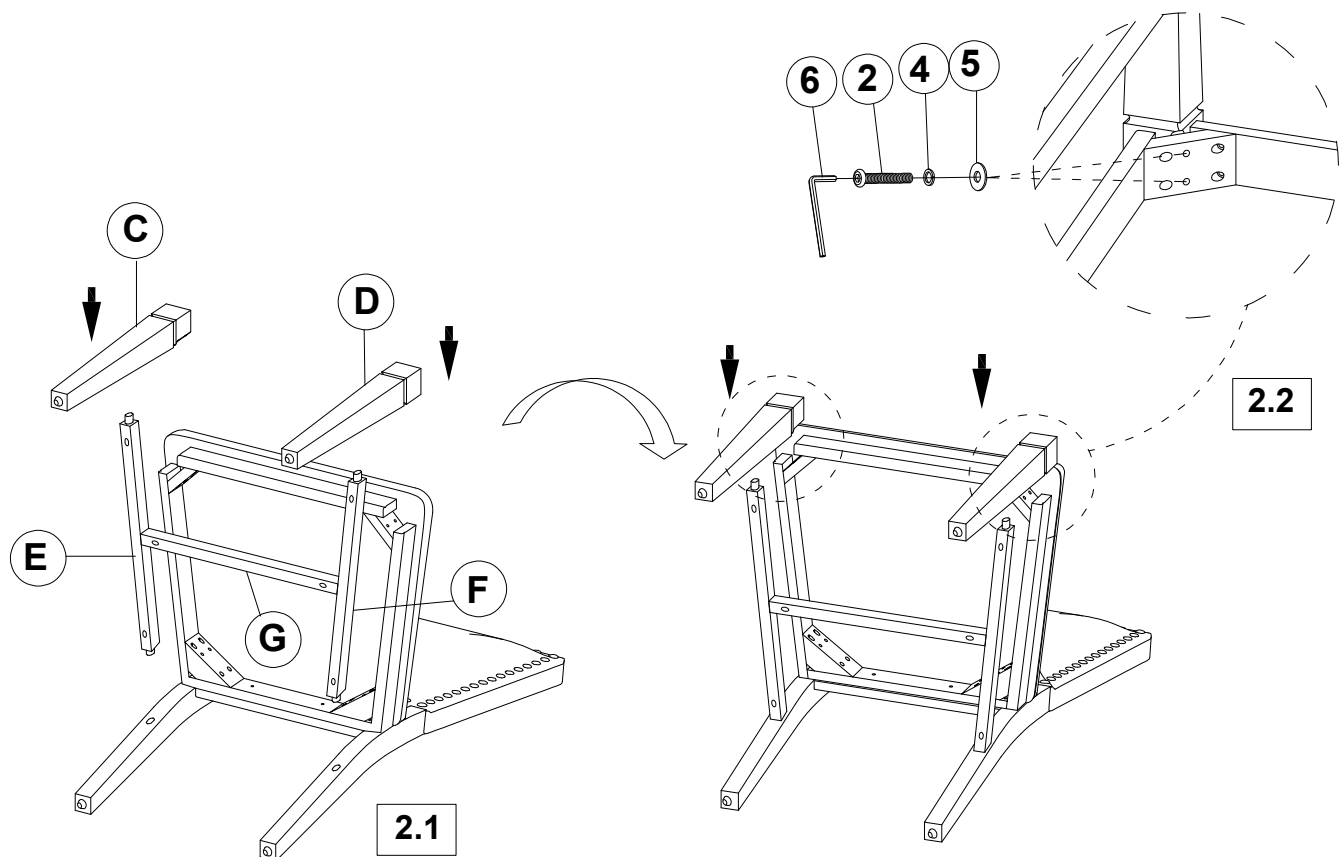

ITEM: **108542**

ASSEMBLY INSTRUCTIONS



STEP 3

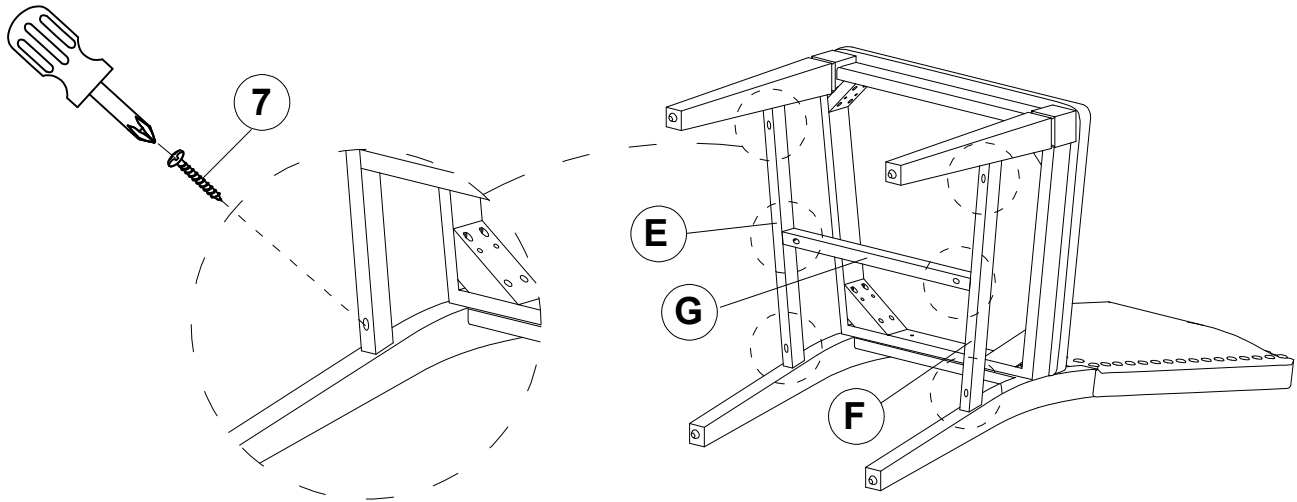

STEP 4

COMPLETE

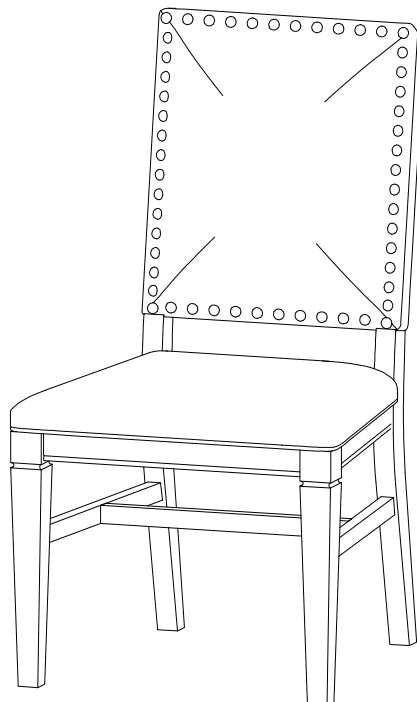

ITEM: 108542

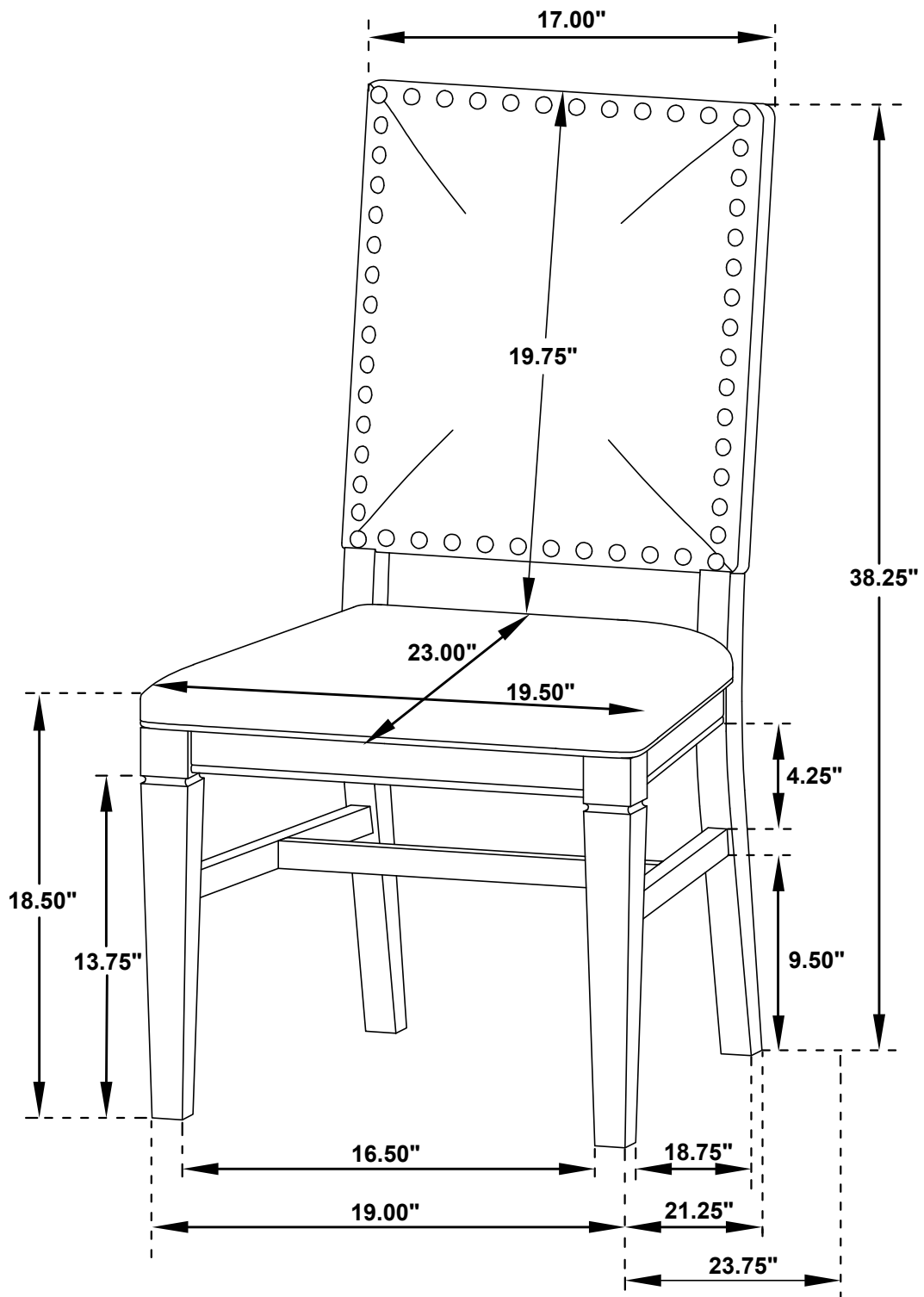

Note: Dimension tolerance $\pm 5\%$



ASSEMBLY INSTRUCTIONS
COASTER FINE FURNITURE



Fine Furniture for every stage of life

108543
Bench

ITEM: 108543



ASSEMBLY INSTRUCTIONS

ASSEMBLY TIPS:

1. Remove hardware from box and sort by size.
2. Please check to see that all hardware and parts are present prior to start of assembly.
3. Please follow attached instructions in the same sequence as numbered to assure fast & easy assembly.



WARNING!

1. Don't attempt to repair or modify parts that are broken or defective. Please contact the store immediately.
2. This product is for home use only and not intended for commercial establishments.



ASSEMBLY TIME

15 MINUTES

PARTS IDENTIFICATION

A SEAT



1PC

C CROSSBAR



1PC

B LEG FRAME



2PCS

HARDWARE IDENTIFICATION

1 BOLT

(Ø5/16" x 1-1/2" - RBW)

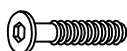

8PCS

3 FLAT WASHER

(Ø5/16" - RBW)



8PCS

2 LOCK WASHER

(Ø5/16" - RBW)



8PCS

4 ALLEN WRENCH

(4MM - RBW)

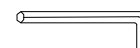

1PC

ITEM: **108543**

ASSEMBLY INSTRUCTIONS



STEP 1

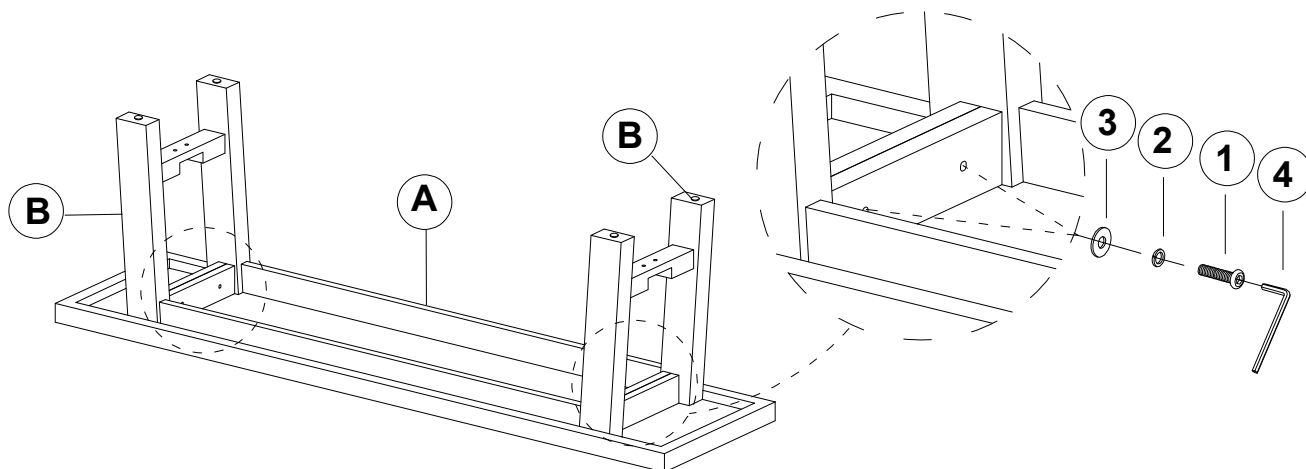

STEP 2

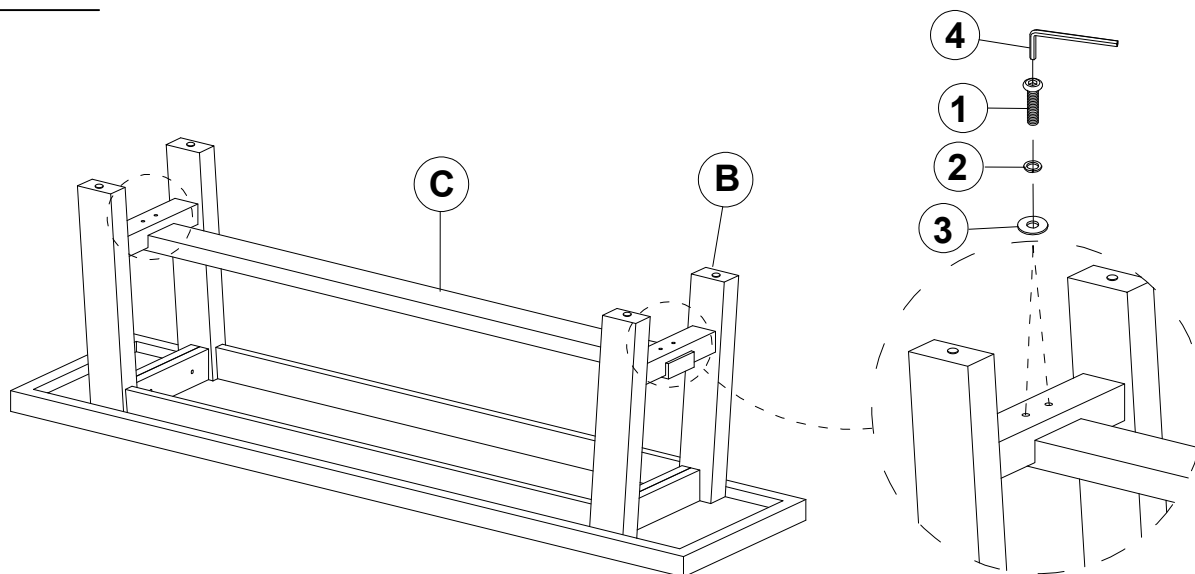

STEP 3
COMPLETE

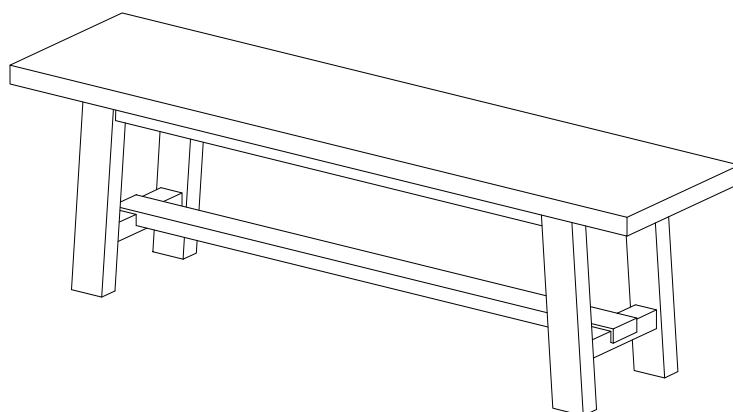

ITEM: **108543**

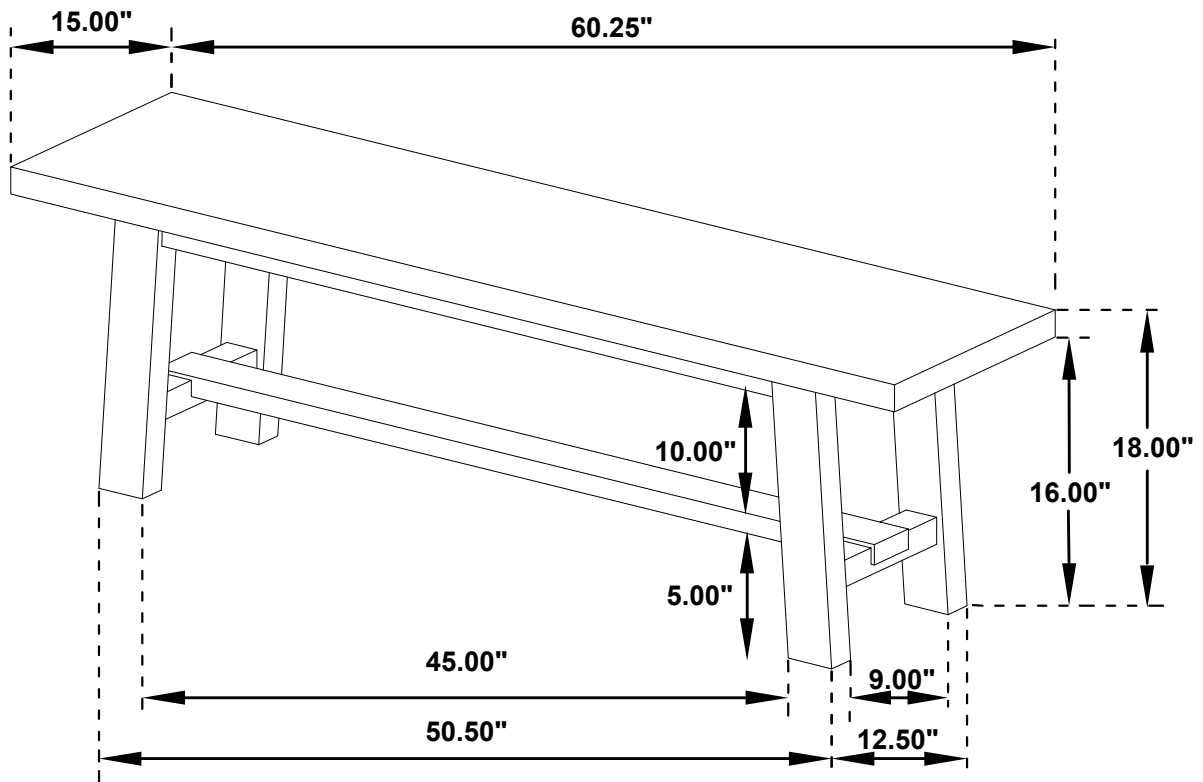

Note: Dimension tolerance $\pm 5\%$