

ASSEMBLY INSTRUCTIONS
COASTER FINE FURNITURE



Fine Furniture for every stage of life

121762
Side Chair

ITEM: 121762



ASSEMBLY INSTRUCTIONS

ASSEMBLY TIPS:

1. Remove hardware from box and sort by size.
2. Please check to see that all hardware and parts are present prior to start of assembly.
3. Please follow attached instructions in the same sequence as numbered to assure fast & easy assembly.



WARNING!

1. Don't attempt to repair or modify parts that are broken or defective. Please contact the store immediately.
2. This product is for home use only and not intended for commercial establishments.









ASSEMBLY TIME

15 MINUTES

PARTS IDENTIFICATION

| | | | |
|---|-------------------------|--|------|
| A | BACK FRAME |  | 1PC |
| B | SEAT CUSHION WITH FRAME |  | 1PC |
| C | FRONT LEG |  | 2PCS |

HARDWARE IDENTIFICATION

| | | | |
|---|--------------------------------------|--|------|
| 1 | LONG BOLT (Ø1/4" x 75mm - RBW) |  | 4PCS |
| 2 | MEDIUM BOLT (Ø1/4" x 60mm - RBW) |  | 4PCS |
| 3 | SHORT BOLT (Ø1/4" x 35mm - RBW) |  | 1PC |
| 4 | LOCK WASHER (Ø5/16" x 13mm - RBW) |  | 9PCS |
| 5 | FLAT WASHER (Ø5/16" x 19mm - RBW) |  | 9PCS |
| 6 | ALLEN WRENCH (M4 x 59mm - RBW) |  | 1PC |

NOTE:

Quantities shown are for one chair.

Phillips head screw driver is required in the assembly process; however, manufacturer does not provide this item.

ITEM: **121762**
ASSEMBLY INSTRUCTIONS



STEP 1

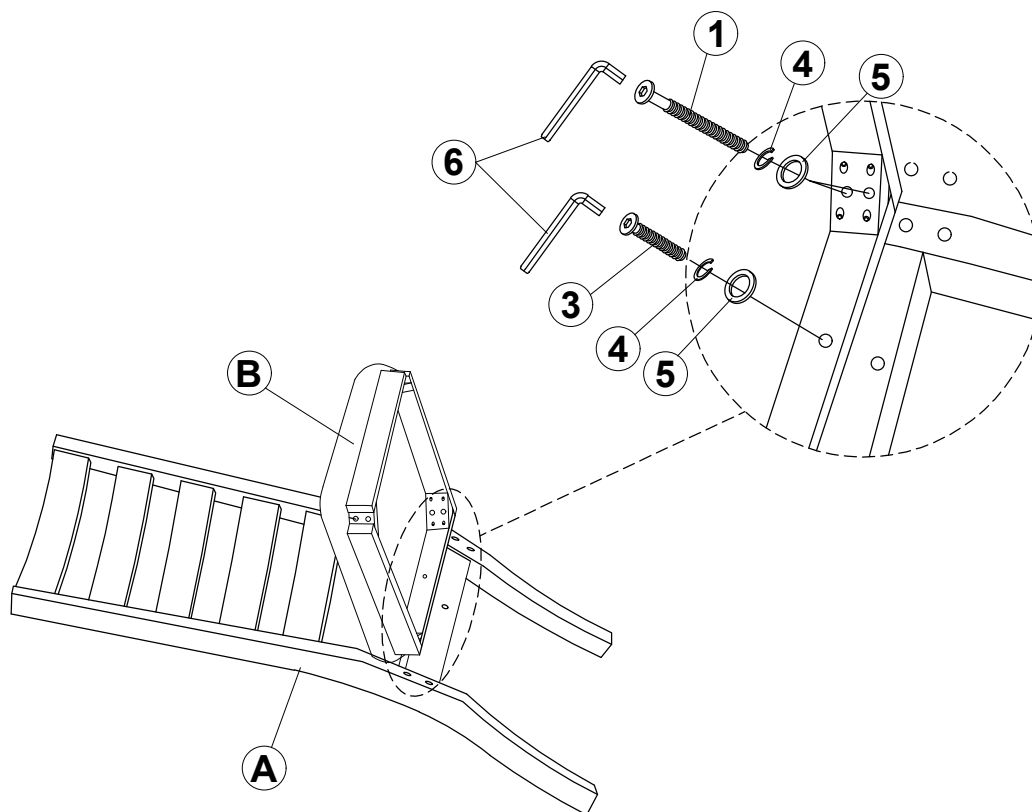

STEP 2

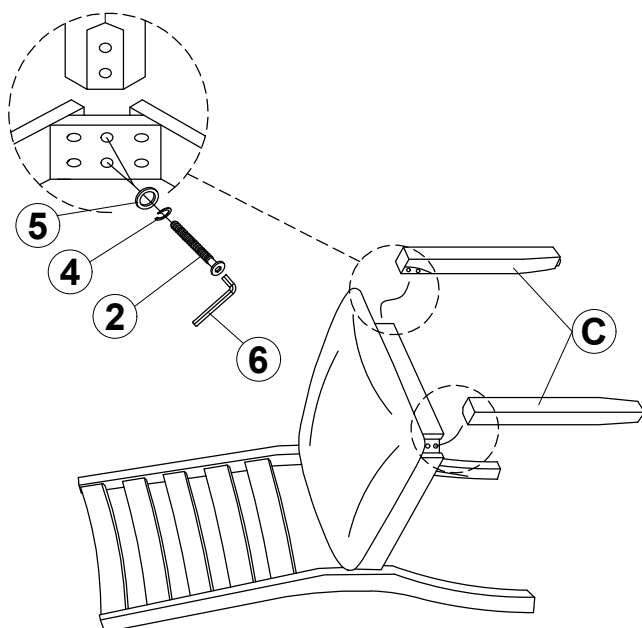

STEP 3
COMPLETE



ITEM: **121762**

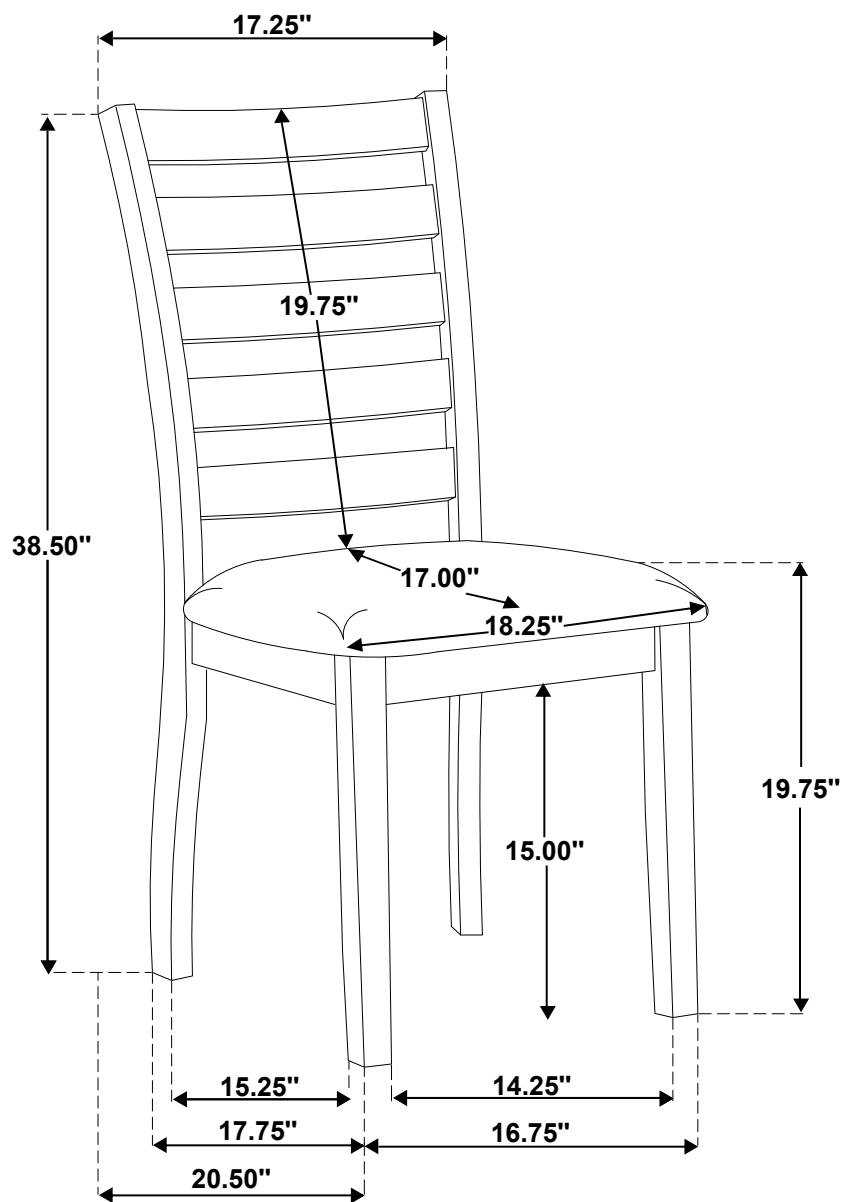

Note: Dimension tolerance $\pm 5\%$