



ASSEMBLY INSTRUCTIONS
COASTER FINE FURNITURE



Fine Furniture for every stage of life

122178
Counter Height
Dining Table Base

ITEM: 122178

ASSEMBLY INSTRUCTIONS

ASSEMBLY TIPS:

1. Remove hardware from box and sort by size.
2. Please check to see that all hardware and parts are present prior to start of assembly.
3. Please follow attached instructions in the same sequence as numbered to assure fast & easy assembly.



WARNING!

1. Don't attempt to repair or modify parts that are broken or defective. Please contact the store immediately.
2. This product is for home use only and not intended for commercial establishments.



ASSEMBLY TIME

15 MINUTES

PARTS IDENTIFICATION

A LEG SUPPORT FRAME

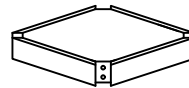

1PC

B LEG



4PCS

C DISC WITH BOLT



4SETS

HARDWARE IDENTIFICATION

1 BOLT
(M8 x 60MM -RBW)



8PCS

2 LOCK WASHER
(M8 x 13MM - RBW)



8PCS

3 FLAT WASHER
(M8 x 22MM - RBW)



8PCS

4 ALLEN WRENCH
(M5 x 65MM -BLK)



1PC

ITEM: **122178**

ASSEMBLY INSTRUCTIONS

STEP 1

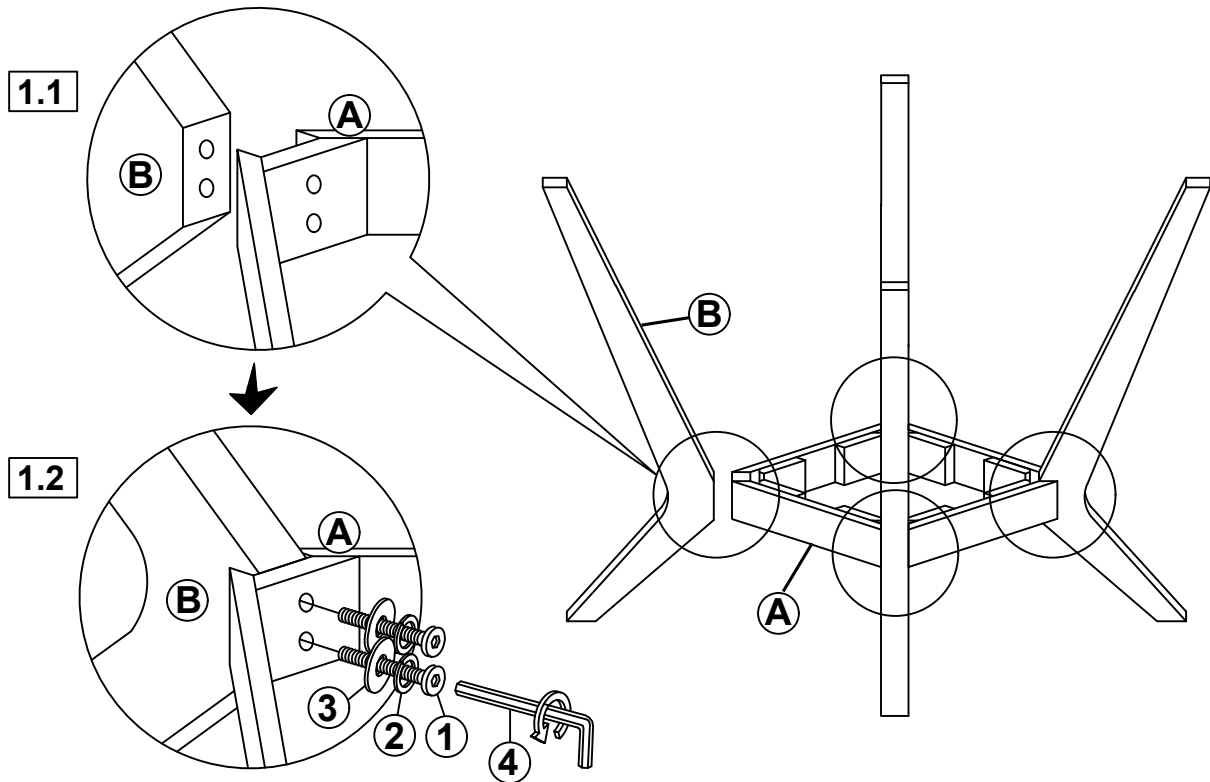

BOTTOM VIEW

STEP 2

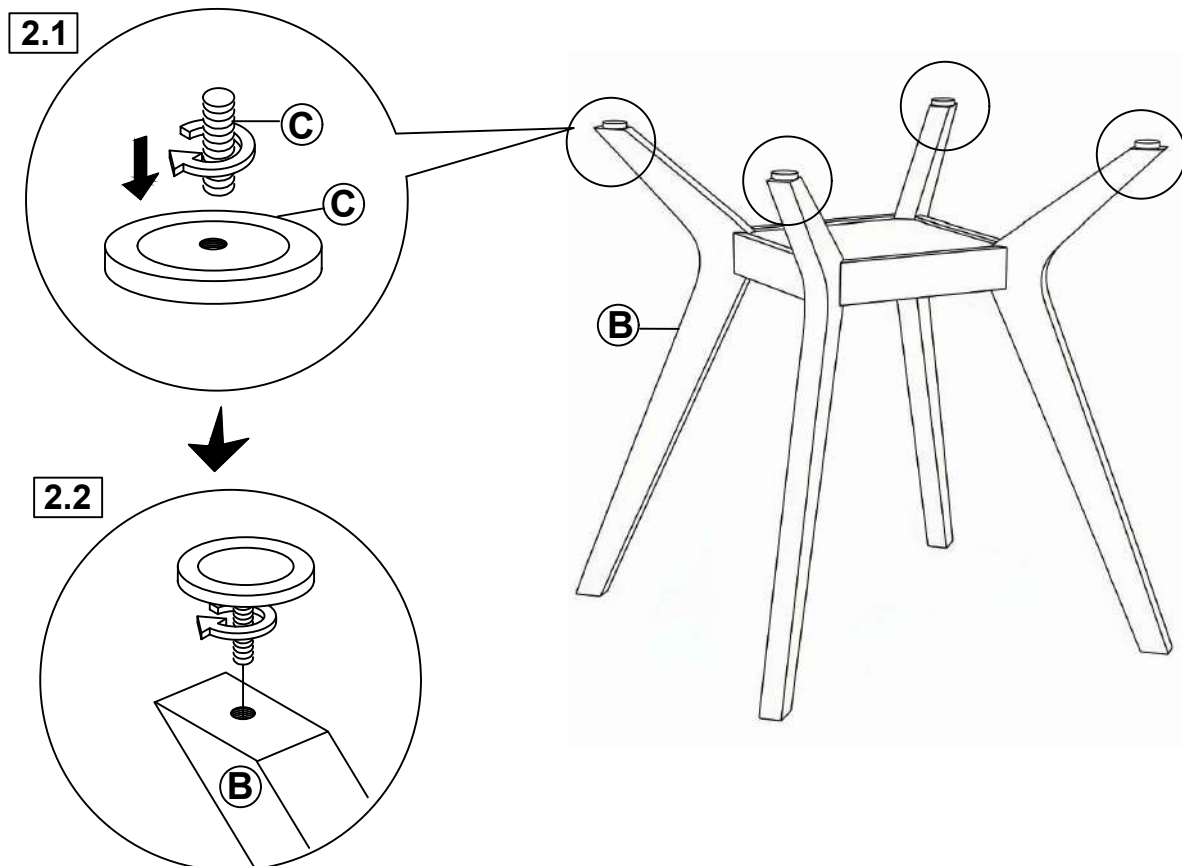

ITEM: **122178**

ASSEMBLY INSTRUCTIONS



STEP 3

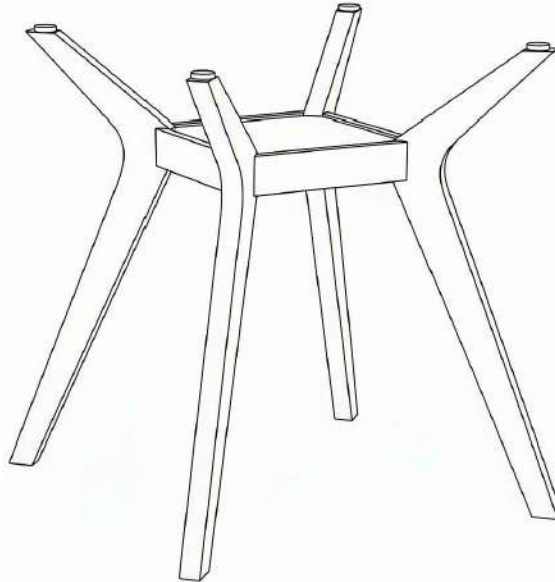

STEP 4
COMPLETE



NOTE : GLASS TOP NOT INCLUDED



ITEM: 122178

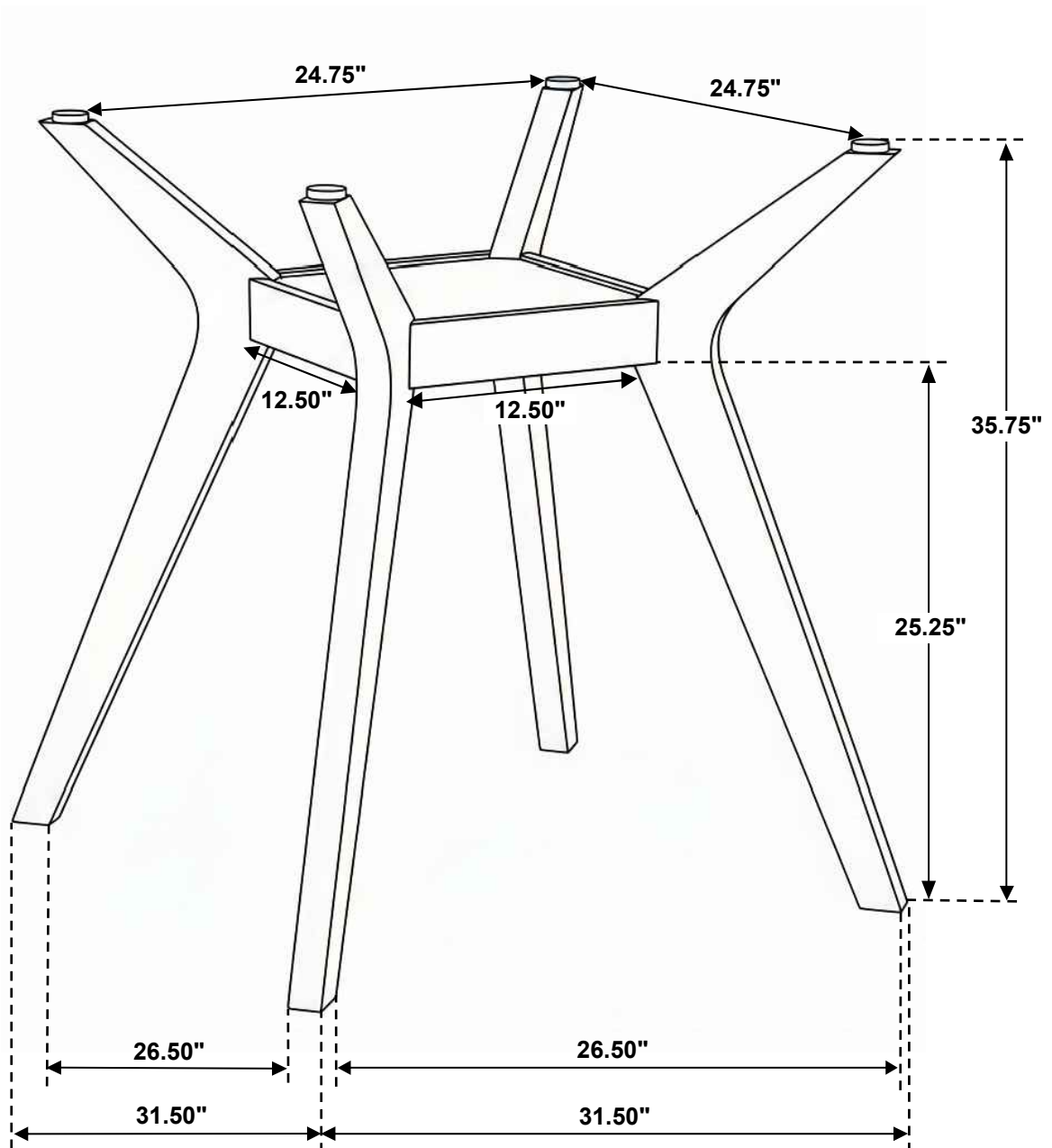

Note: Dimension tolerance $\pm 5\%$



ASSEMBLY INSTRUCTIONS
COASTER FINE FURNITURE



Fine Furniture for every stage of life

122178BG
Counter Height Dining Table

ITEM: 122178BG



ASSEMBLY INSTRUCTIONS

ASSEMBLY TIPS:

1. Remove hardware from box and sort by size.
2. Please check to see that all hardware and parts are present prior to start of assembly.
3. Please follow attached instructions in the same sequence as numbered to assure fast & easy assembly.



WARNING!

1. Don't attempt to repair or modify parts that are broken or defective. Please contact the store immediately.
2. This product is for home use only and not intended for commercial establishments.



ASSEMBLY TIME

15 MINUTES

PARTS IDENTIFICATION

A LEG SUPPORT FRAME

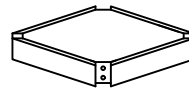

1PC

B LEG



4PCS

C DISC WITH BOLT



4SETS

D GLASS TOP
FROM BOX ITEM# CB48RD-6



1PC

HARDWARE IDENTIFICATION

1 BOLT
(M8 x 60MM -RBW)



8PCS

2 LOCK WASHER
(M8 x 13MM - RBW)



8PCS

3 FLAT WASHER
(M8 x 22MM - RBW)



8PCS

4 ALLEN WRENCH
(M5 x 65MM -BLK)



1PC

ITEM: **122178BG**

ASSEMBLY INSTRUCTIONS

STEP 1

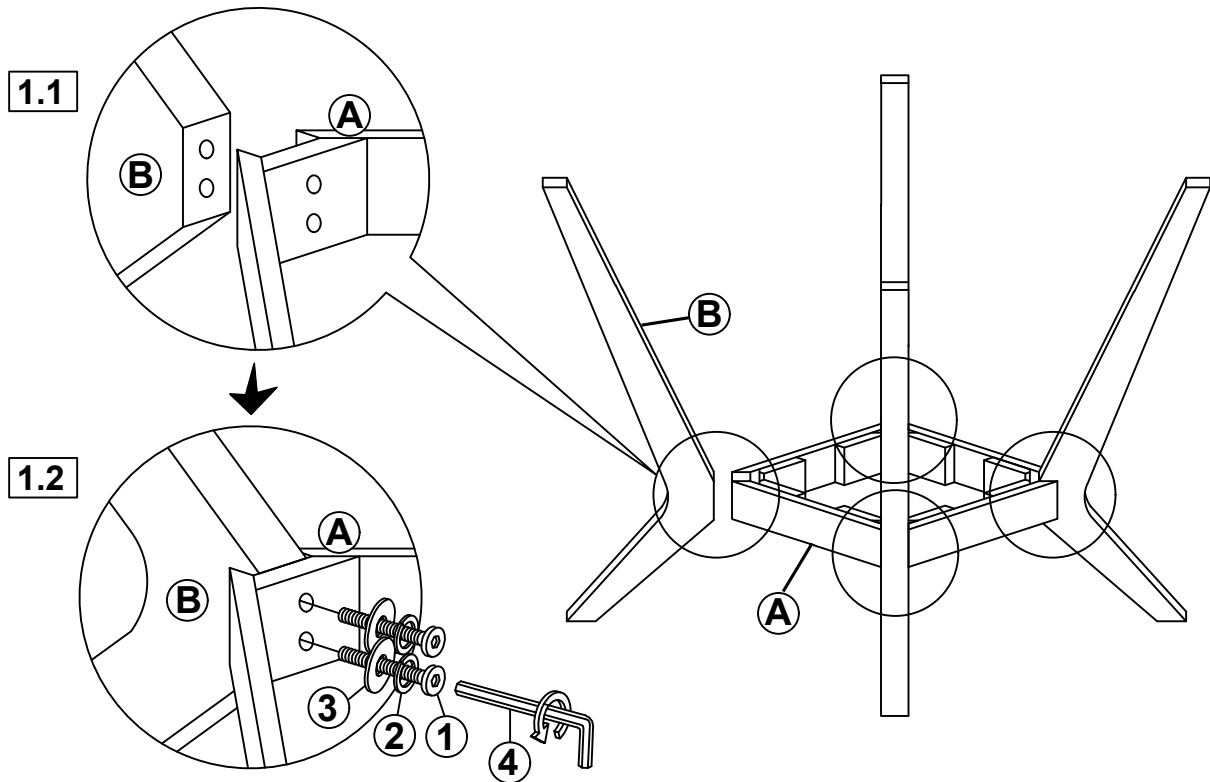

BOTTOM VIEW

STEP 2

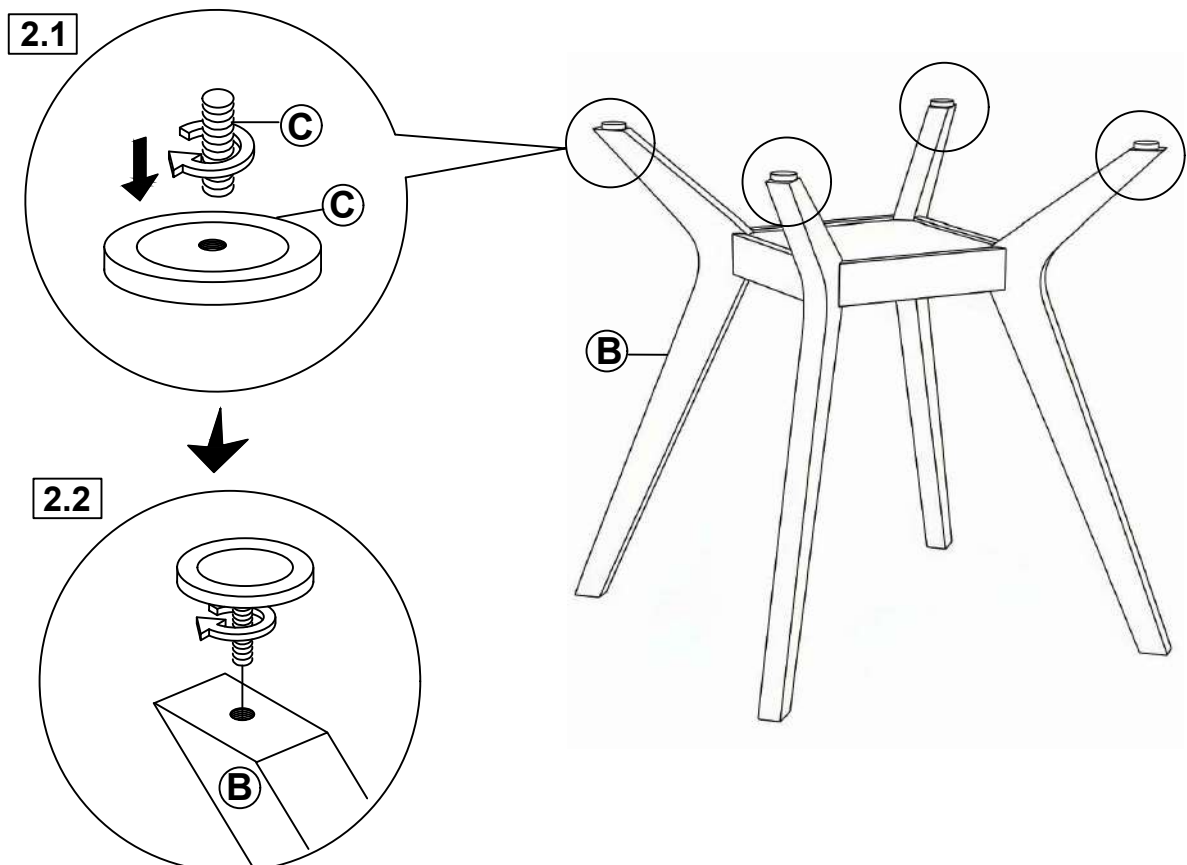

ITEM: **122178BG**

ASSEMBLY INSTRUCTIONS



STEP 3



STEP 4
COMPLETE

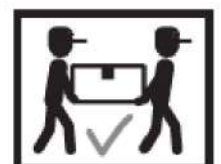

ITEM: **122178BG**

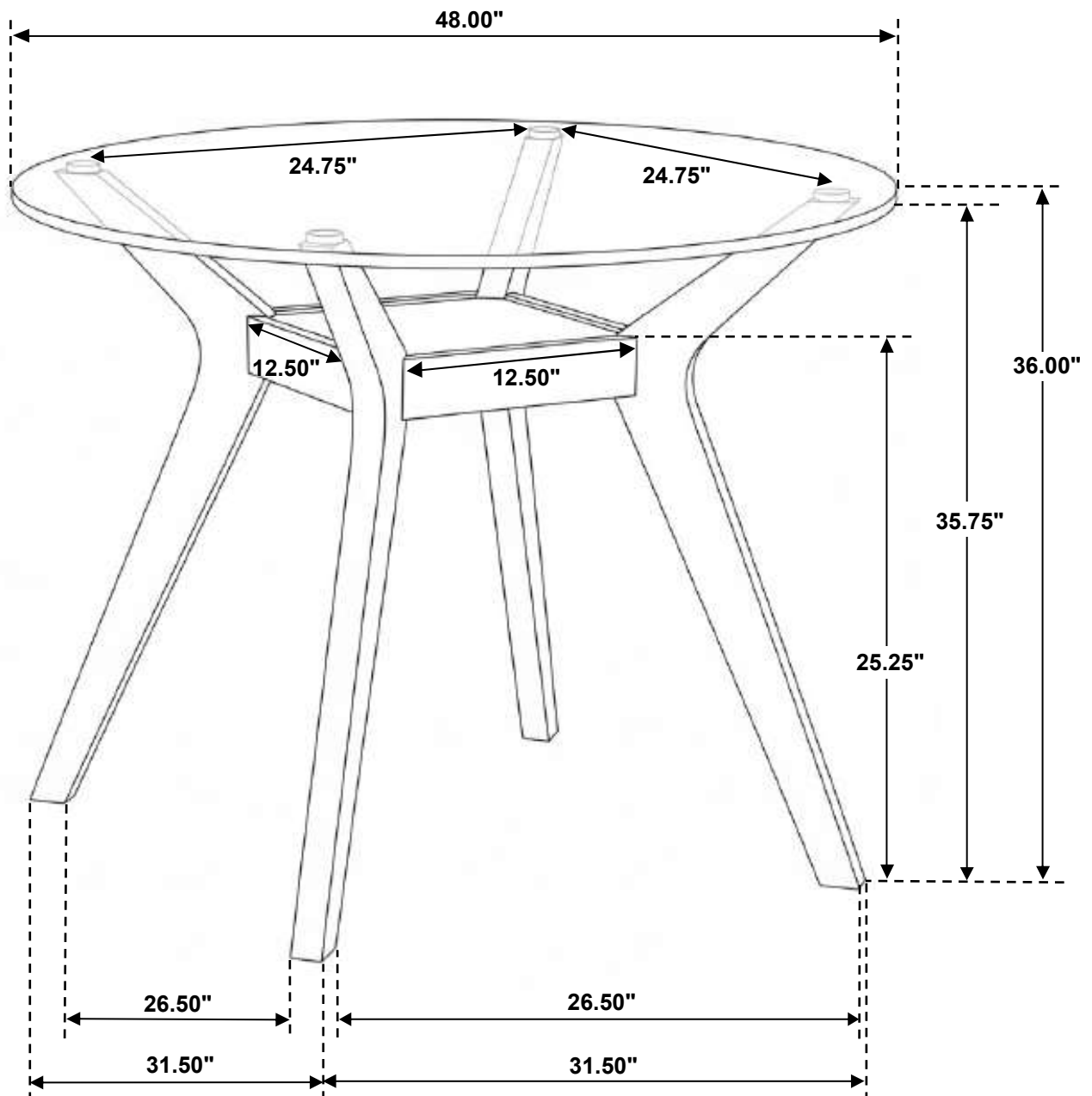

Note: Dimension tolerance $\pm 5\%$



ASSEMBLY INSTRUCTIONS
COASTER FINE FURNITURE



Fine Furniture for every stage of life

122179BGE
Counter Chair

ITEM: 122179BGE

ASSEMBLY INSTRUCTIONS



ASSEMBLY TIPS:

1. Remove hardware from box and sort by size.
2. Please check to see that all hardware and parts are present prior to start of assembly.
3. Please follow attached instructions in the same sequence as numbered to assure fast & easy assembly.



WARNING!





1. Don't attempt to repair or modify parts that are broken or defective. Please contact the store immediately.
2. This product is for home use only and not intended for commercial establishments.







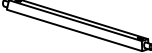

ASSEMBLY TIME

10 MINUTES

PARTS IDENTIFICATION

A	BACK FRAME		1PC
B	SEAT CUSHION		1PC
C	RIGHT LEG WITH LABEL "R"		1PC
D	LEFT LEG WITH LABEL "L"		1PC
E	FRONT STRETCHER		1PC
F	RIGHT STRECTHER WITH LABEL "R"		1PC
G	LEFT STRECTHER WITH LABEL "L"		1PC

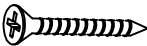
HARDWARE IDENTIFICATION

1	SHORT BOLT (M6 x 40MM - RBW)		2PCS
2	MEDIUM BOLT (M6 x 60MM - RBW)		4PCS
3	LONG BOLT (M6 x 80MM - RBW)		4PCS
4	LOCK WASHER (M6 x 12MM - RBW)		10PCS
5	FLAT WASHER (M6 x 19MM - RBW)		10PCS
6	FLAT HEAD SCREW (M4 x 38MM - RBW)		6PCS
7	ALLEN WRENCH (M4 x 100MM - BLK)		1PC

NOTE:

Quantities shown are for one chair.

Phillips head screw driver is required in the assembly process; however, manufacturer does not provide this item.

ITEM: **122179BGE**
ASSEMBLY INSTRUCTIONS

STEP 1

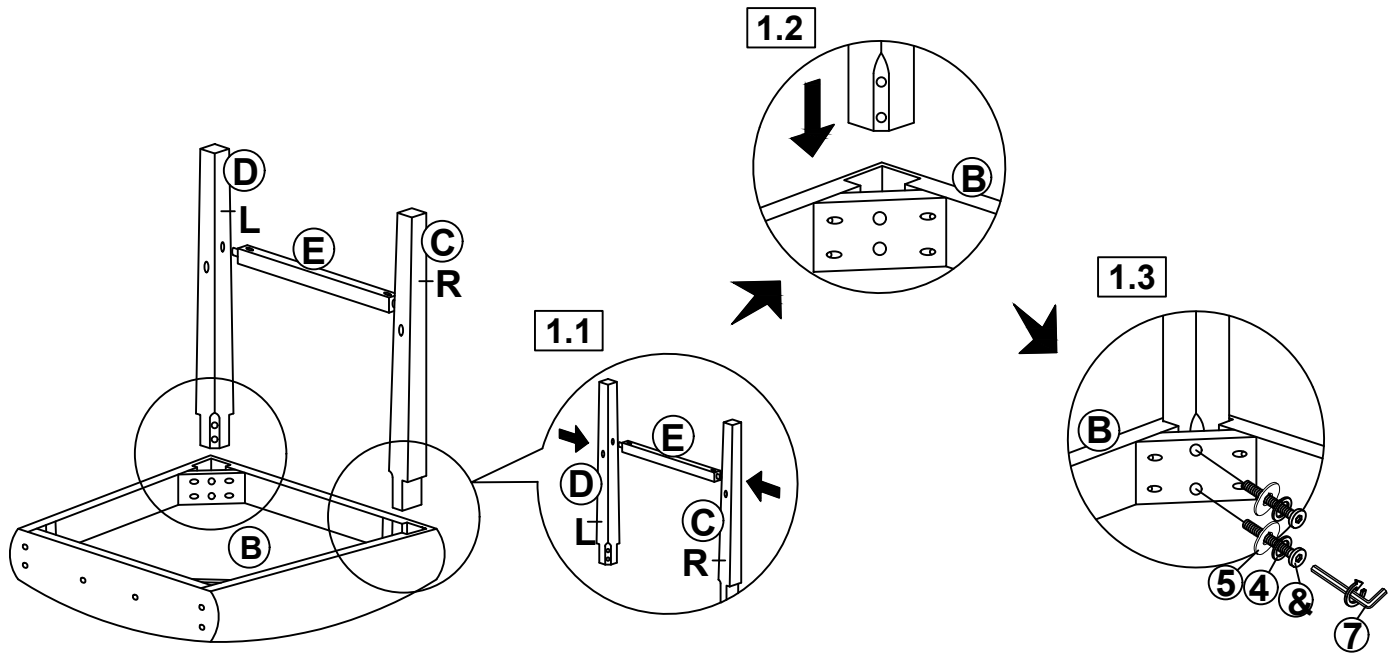

STEP 2

Do not fully tighten screws
in this step.

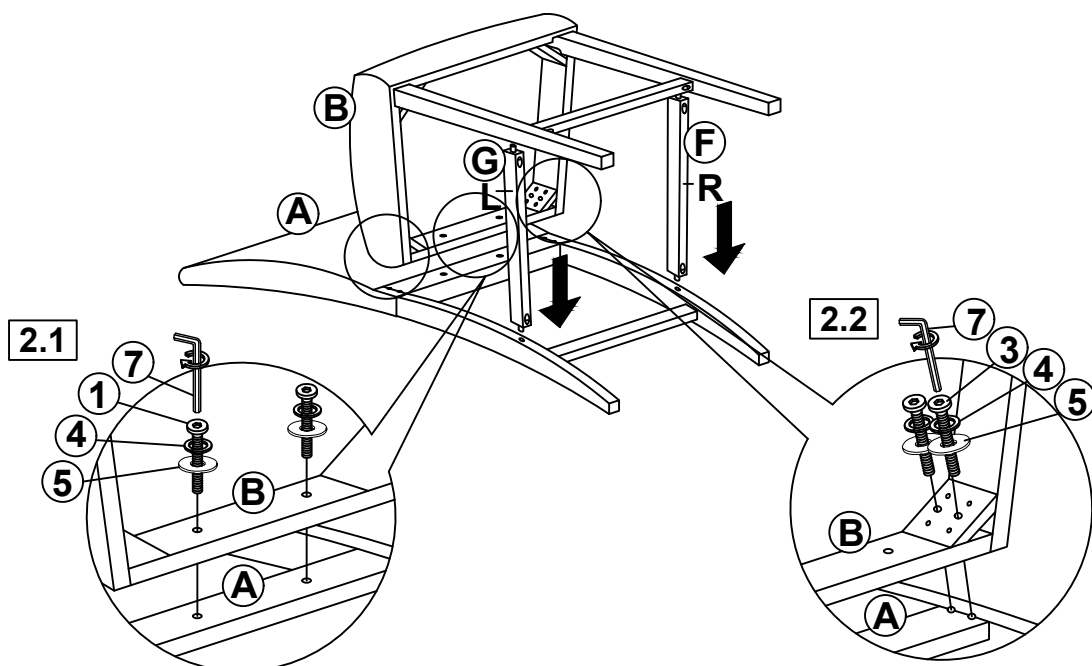

ITEM: **122179BGE**

ASSEMBLY INSTRUCTIONS

STEP 3

Place the chair on the flat surface and make sure the chair is level. Completely tighten the screw after Step 3.

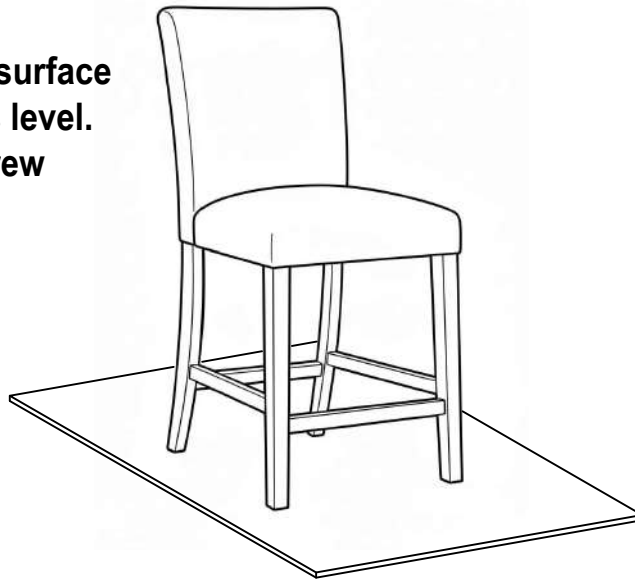

STEP 4

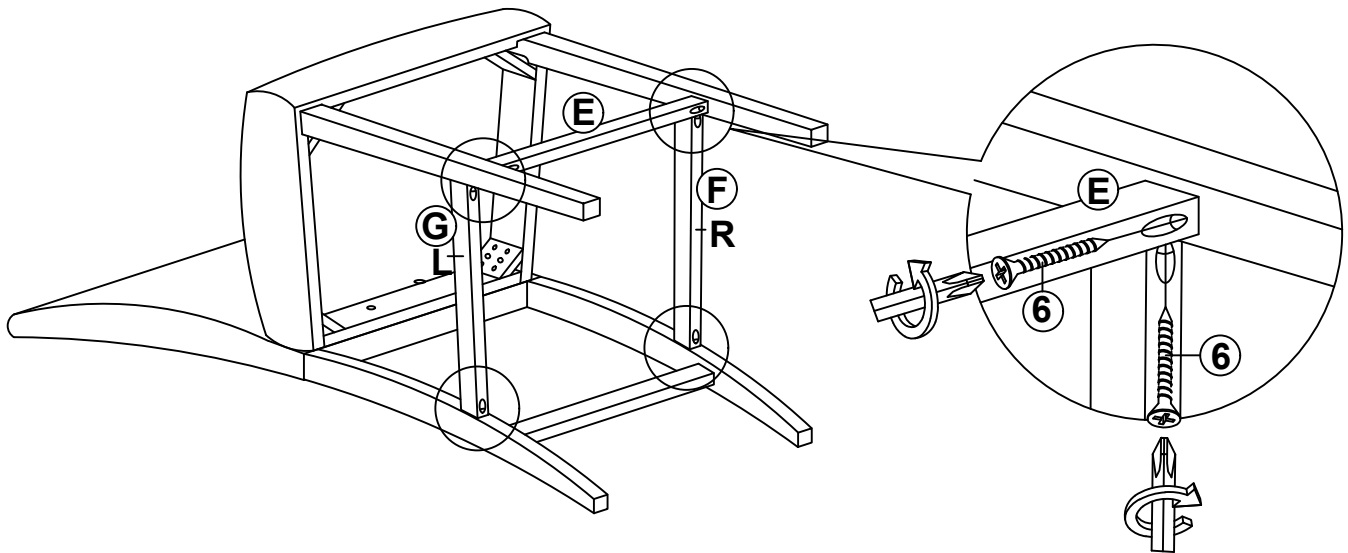

STEP 5
COMPLETE

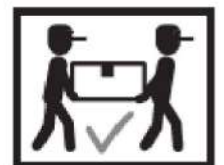

ITEM: **122179BGE**

COASTER
FINE FURNITURE

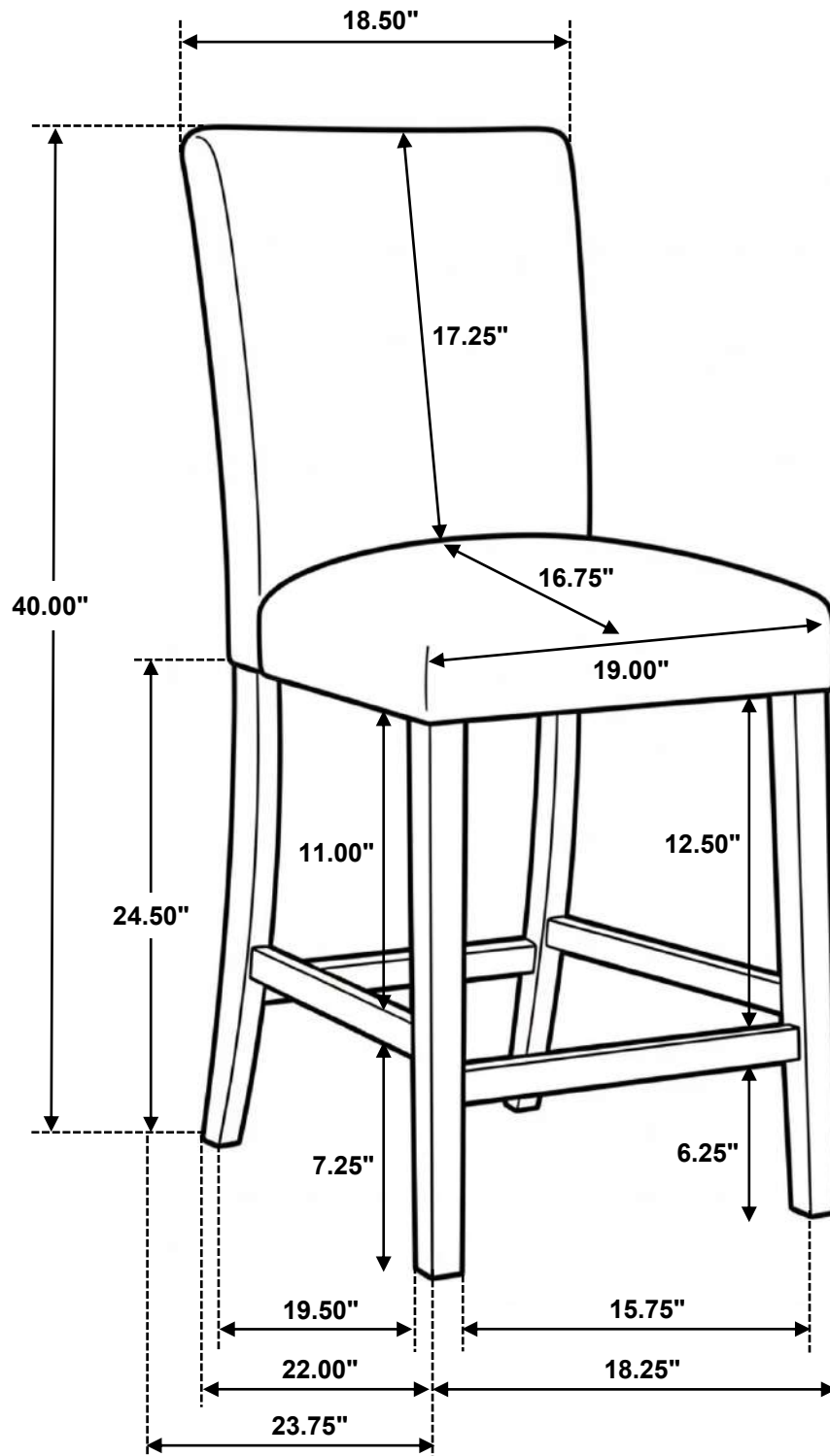

Note: Dimension tolerance $\pm 5\%$