

ASSEMBLY INSTRUCTIONS
COASTER FINE FURNITURE



Fine Furniture for every stage of life

150232
5 Pcs Dining Set

ITEM: 150232

ASSEMBLY INSTRUCTIONS



ASSEMBLY TIPS:

1. Remove hardware from box and sort by size.
2. Please check to see that all hardware and parts are present prior to start of assembly.
3. Please follow attached instructions in the same sequence as numbered to assure fast & easy assembly.



WARNING!





1. Don't attempt to repair or modify parts that are broken or defective. Please contact the store immediately.
2. This product is for home use only and not intended for commercial establishments.

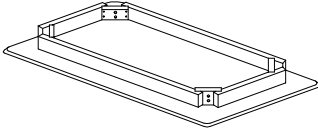
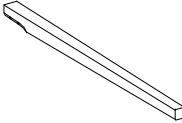
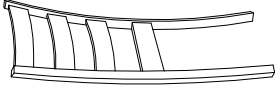
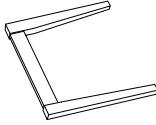

ASSEMBLY TIME

60 MINUTES

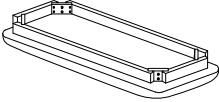
PARTS IDENTIFICATION

A	TABLE TOP		1PC
B	TABLE LEG		4PCS
C	CHAIR BACK FRAME		3PCS
D	CHAIR FRONT LEG FRAME		3PCS
E	CHAIR SIDE RAIL		6PCS
F	CHAIR SEAT CUSHION		3PCS
G	BENCH CUSHION		1PC
H	BENCH LEG		4PCS

ITEM: 150232

ASSEMBLY INSTRUCTIONS



ASSEMBLY TIPS:





1. Remove hardware from box and sort by size.
2. Please check to see that all hardware and parts are present prior to start of assembly.
3. Please follow attached instructions in the same sequence as numbered to assure fast & easy assembly.

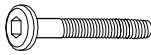
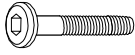

WARNING!

1. Don't attempt to repair or modify parts that are broken or defective. Please contact the store immediately.
2. This product is for home use only and not intended for commercial establishments.

HARDWARE IDENTIFICATION

1	ALLEN WRENCH (M4 x 100mm - BLK)		1PC
2	LONG BOLT (M6 x 60mm- RBW)		16PCS
3	SHORT BOLT (M6 x 50mm- RBW)		18PCS
4	LOCK WASHER (1/4" - BLK)		34PCS
5	FLAT WASHER (5/16" - RBW)		16PCS
6	PAN HEAD SCREW (#8 X 1 1/4" - BLK)		9PCS

NOTE :

Phillips head screw driver is required in the assembly process ; However, manufacturer does not provide this item.

ITEM: **150232**

ASSEMBLY INSTRUCTIONS

STEP 1

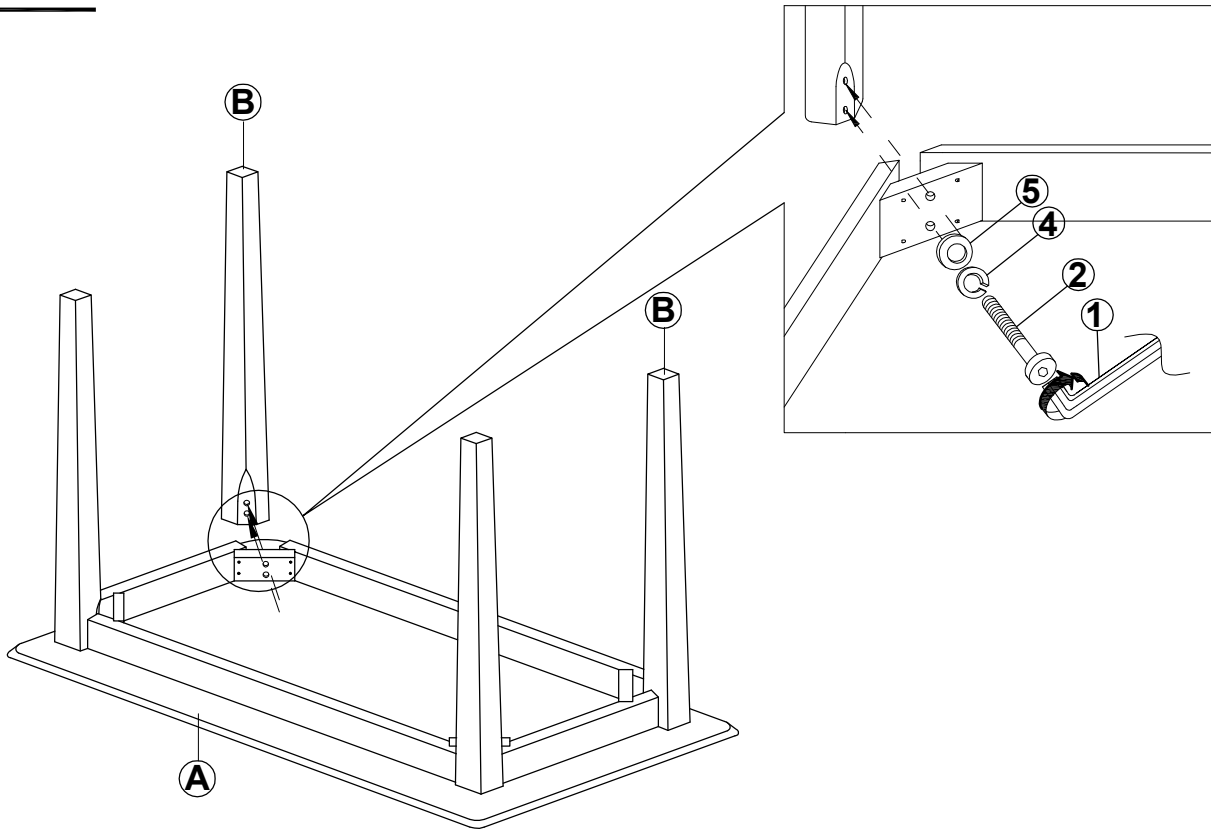

STEP 2

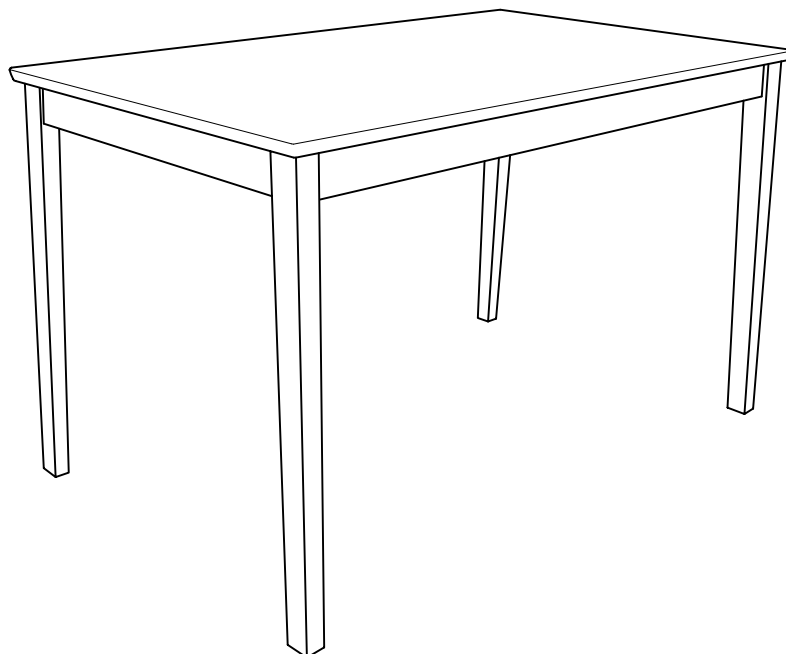

ITEM: **150232**



ASSEMBLY INSTRUCTIONS

STEP 3

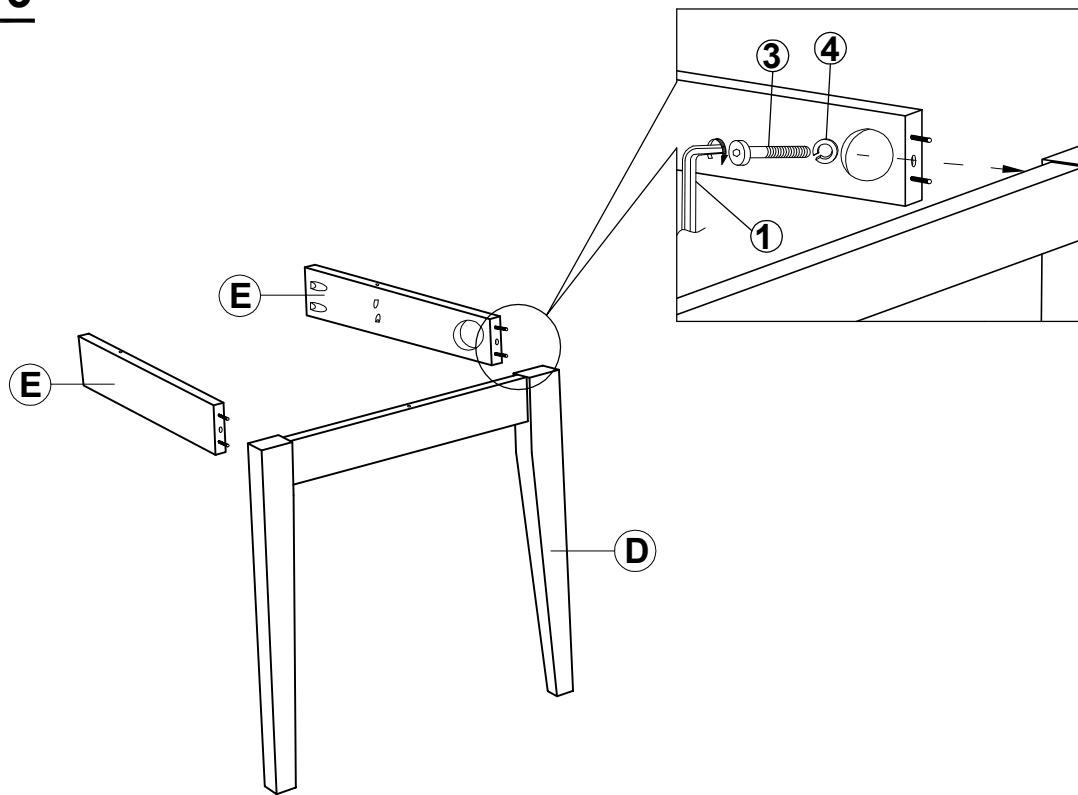

STEP 4

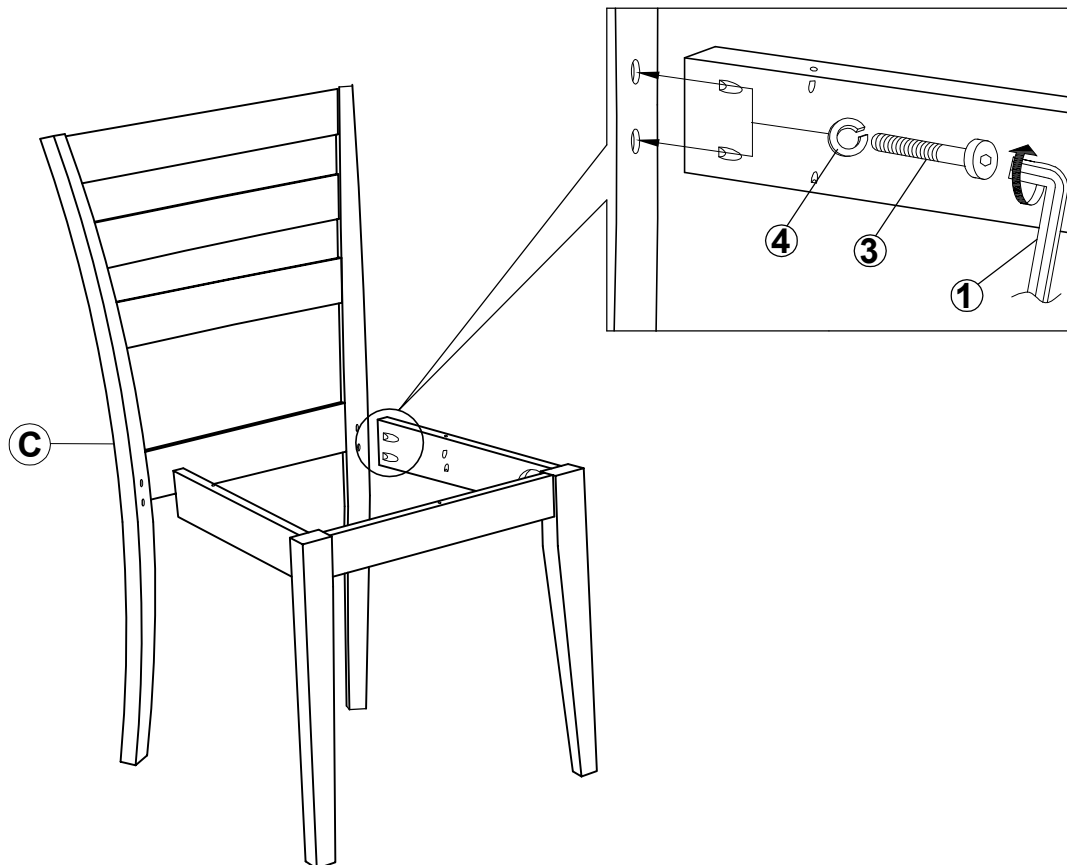

ITEM: **150232**

ASSEMBLY INSTRUCTIONS

STEP 5

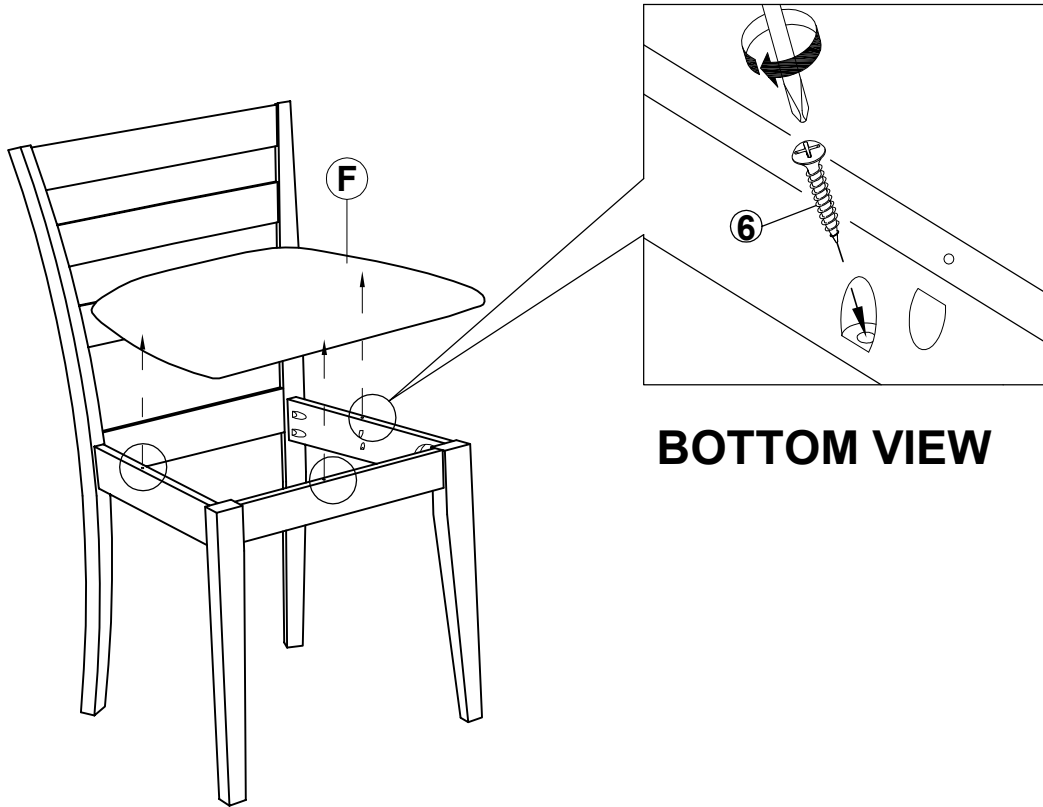

STEP 6

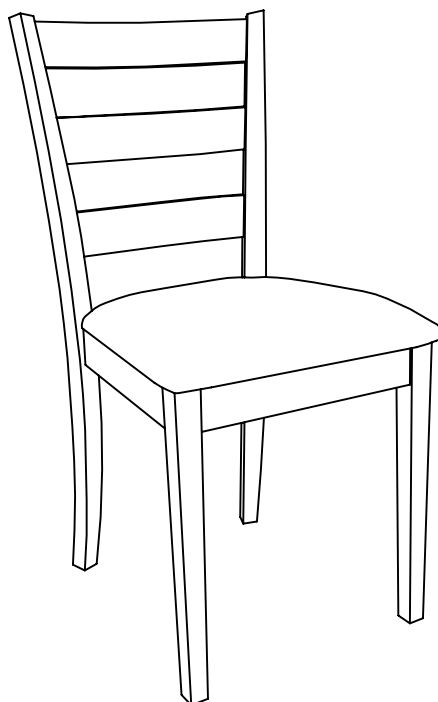

ITEM: **150232**

ASSEMBLY INSTRUCTIONS



STEP 7

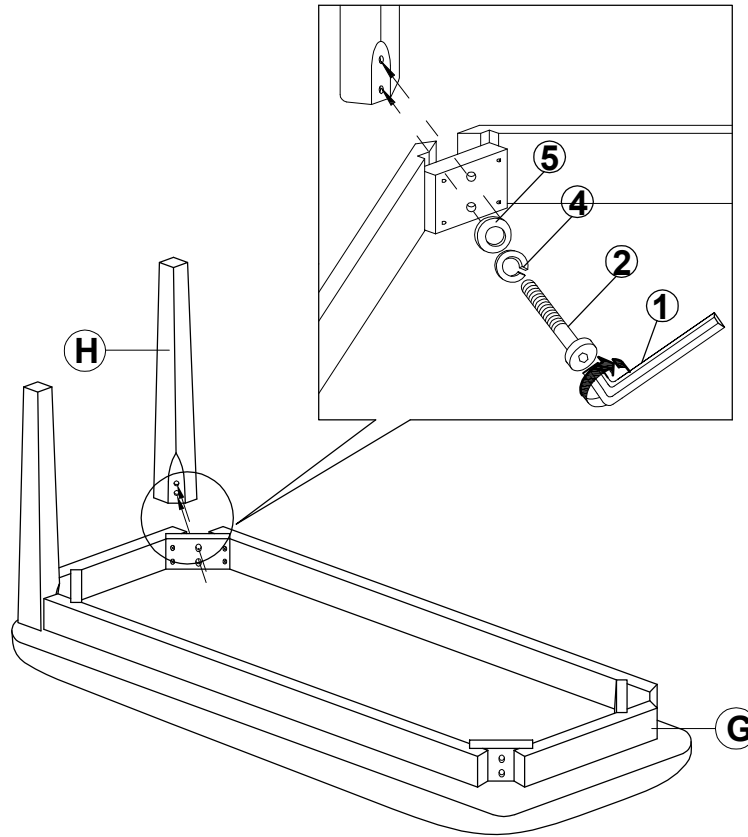

STEP 8
COMPLETE

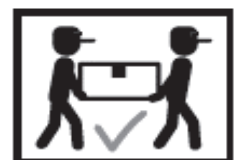
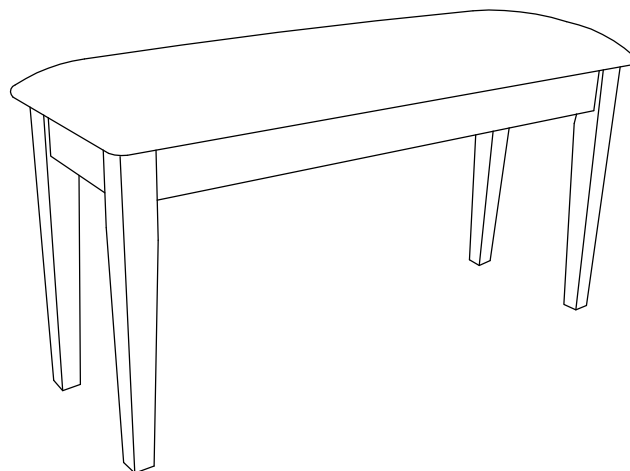

ITEM: 150232

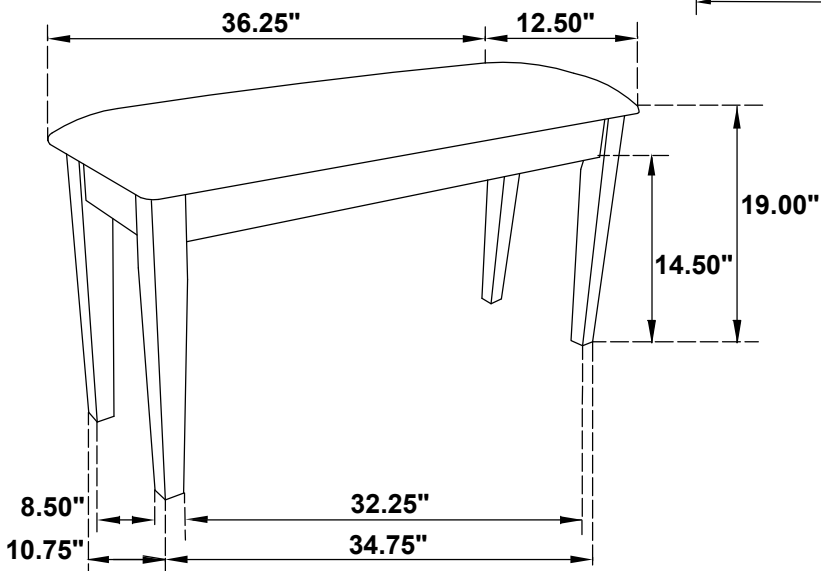
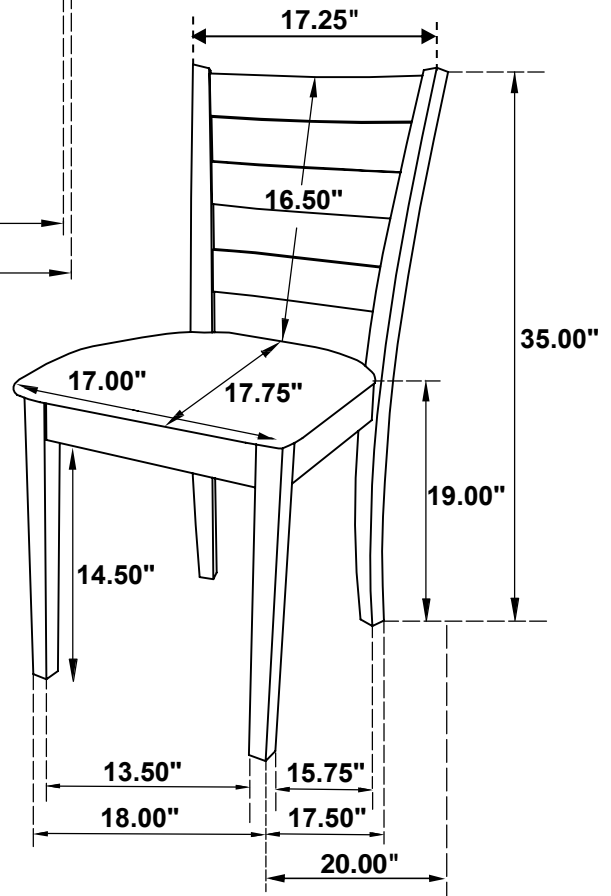
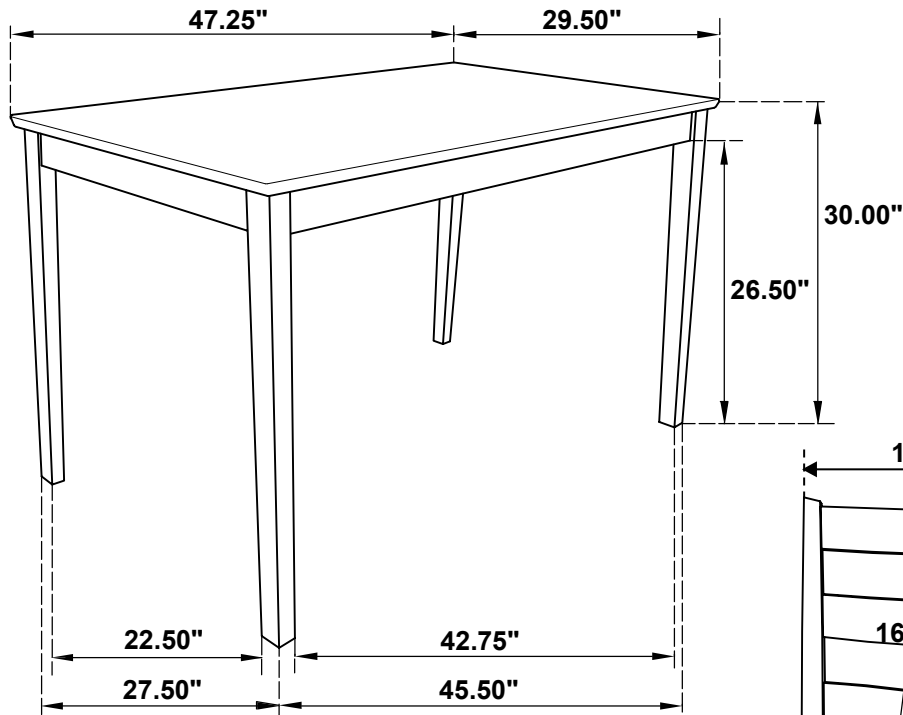

Note: Dimension tolerance $\pm 5\%$