



*ASSEMBLY INSTRUCTIONS*  
*COASTER FINE FURNITURE*



*Fine Furniture for every stage of life*

**182438(B1&B2)**  
***Counter Height Dining Table***

# ITEM: 182438(B1&B2)

## ASSEMBLY INSTRUCTIONS

### ASSEMBLY TIPS:

1. Remove hardware from box and sort by size.
2. Please check to see that all hardware and parts are present prior to start of assembly.
3. Please follow attached instructions in the same sequence as numbered to assure fast & easy assembly.



### WARNING!

1. Don't attempt to repair or modify parts that are broken or defective. Please contact the store immediately.
2. This product is for home use only and not intended for commercial establishments.



ASSEMBLY TIME

15 MINUTES

## PARTS IDENTIFICATION

### B1 (BOX1)

A TOP

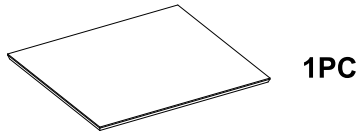

1PC

### B2 (BOX2)

B LEG FRAME

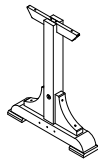

2PCS

D STRETCHER

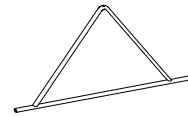

1PC







C TRESTLE BAR

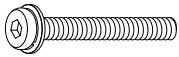

1PC

## HARDWARE IDENTIFICATION

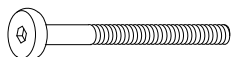
### Z-B2 (BOX 2) - HARDWARE PACK IS LOCATED IN 182438 (B2)

- |   |                                       |   |      |   |   |   |      |
|---|---------------------------------------|---|------|---|---|---|------|
| 1 | <b>BOLT 1</b><br>(Ø 1/4 x 30mm- BLK)  |  | 1PC  | 4 | <b>ALLEN WRENCH</b><br>(M4- 64mm - BLK) |  | 1PC  |
| 2 | <b>BOLT 2</b><br>(Ø 1/4 x 60mm- BLK)  |  | 6PCS | 5 | <b>WOOD DOWEL</b><br>(Ø8 x 40mm)        |  | 4PCS |
| 3 | <b>BOLT 3</b><br>(Ø 1/4 x 100mm- BLK) |  | 2PCS | 6 | <b>WOOD CAP</b><br>(Ø 22 x 35mm)        |  | 2PCS |

# ITEM: 182438(B1&B2)

## ASSEMBLY INSTRUCTIONS

### STEP 1

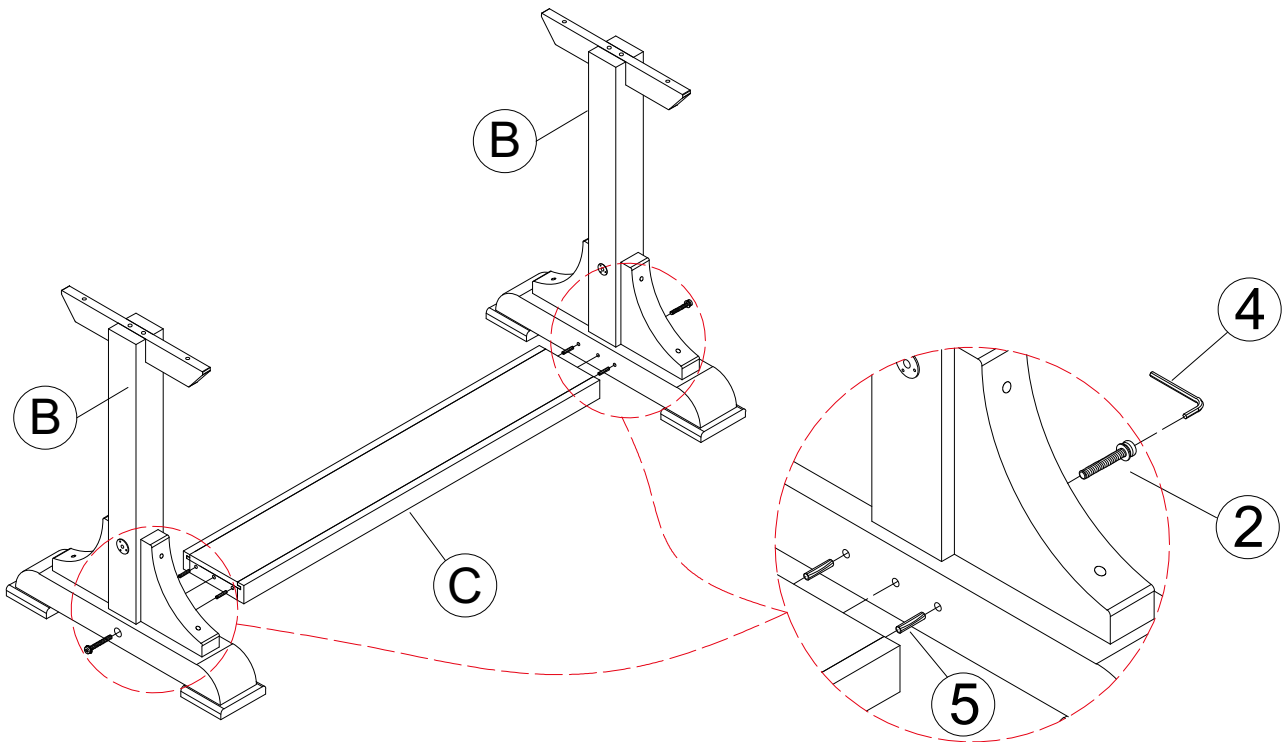

### STEP 2

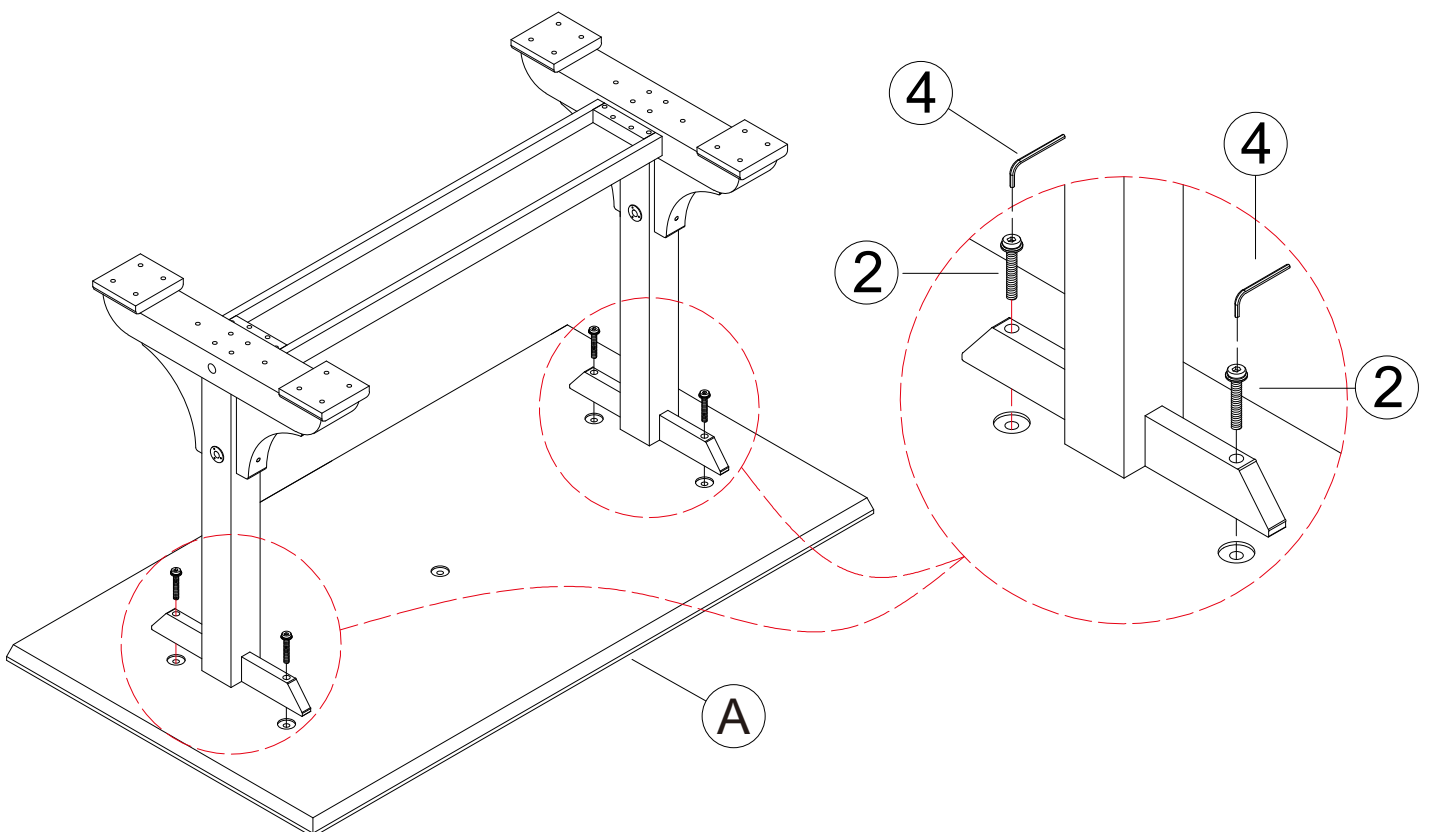

# ITEM: 182438(B1&B2)

## ASSEMBLY INSTRUCTIONS

### STEP 3

**3.2**

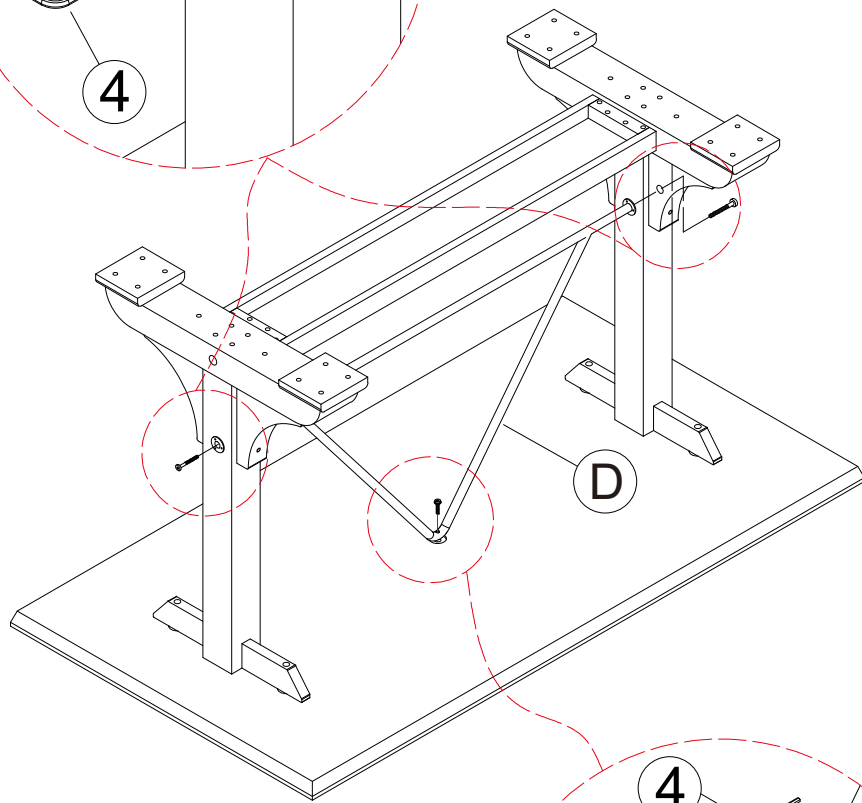
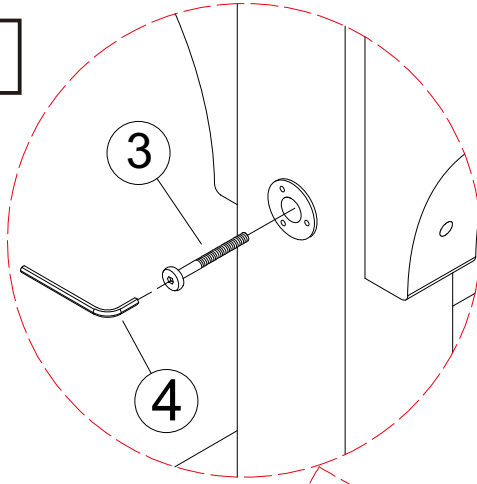

**3.1**

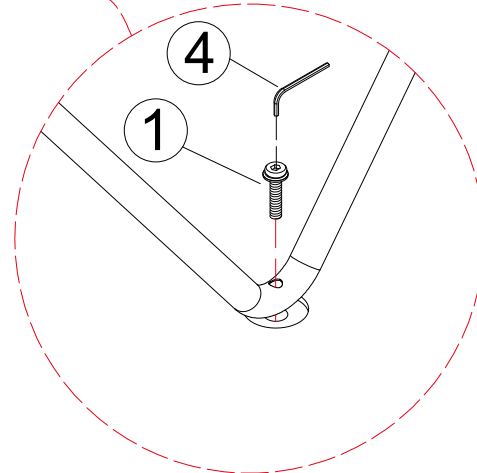

ITEM: **182438(B1&B2)**

**ASSEMBLY INSTRUCTIONS**



**STEP 4**

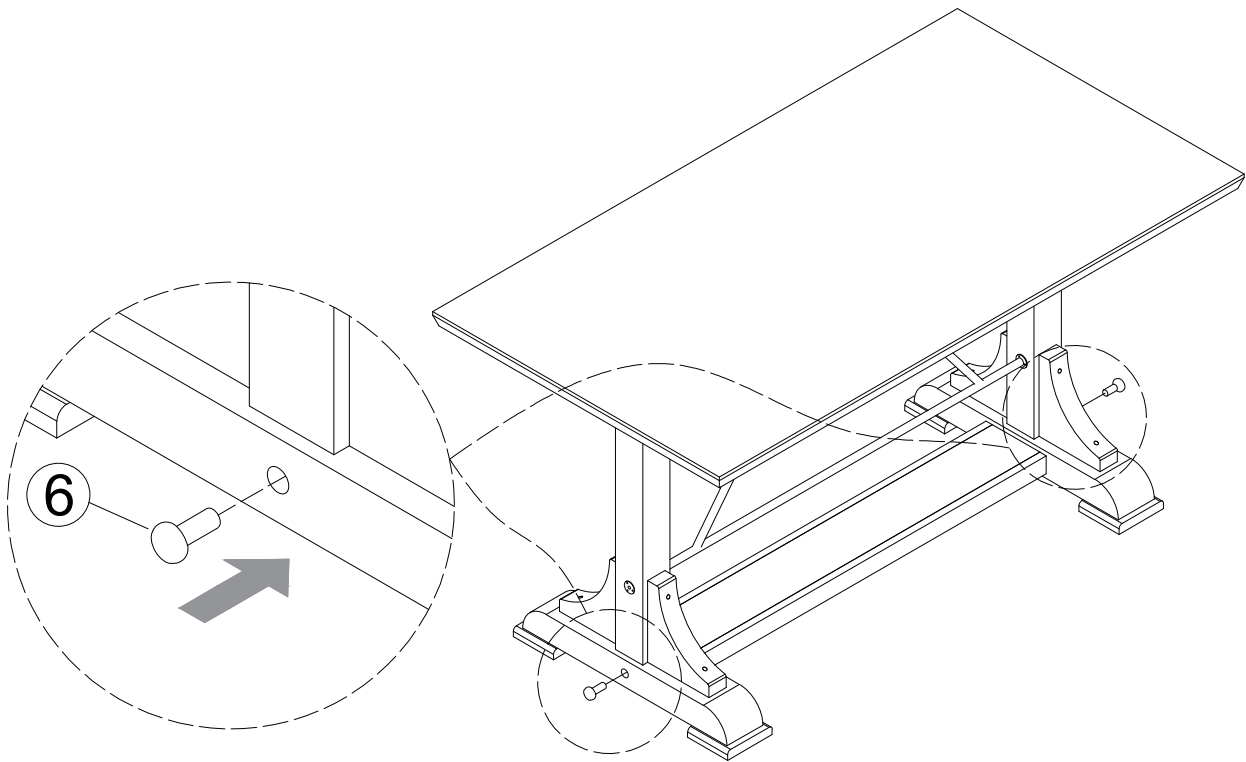

**STEP 5**  
**COMPLETE**

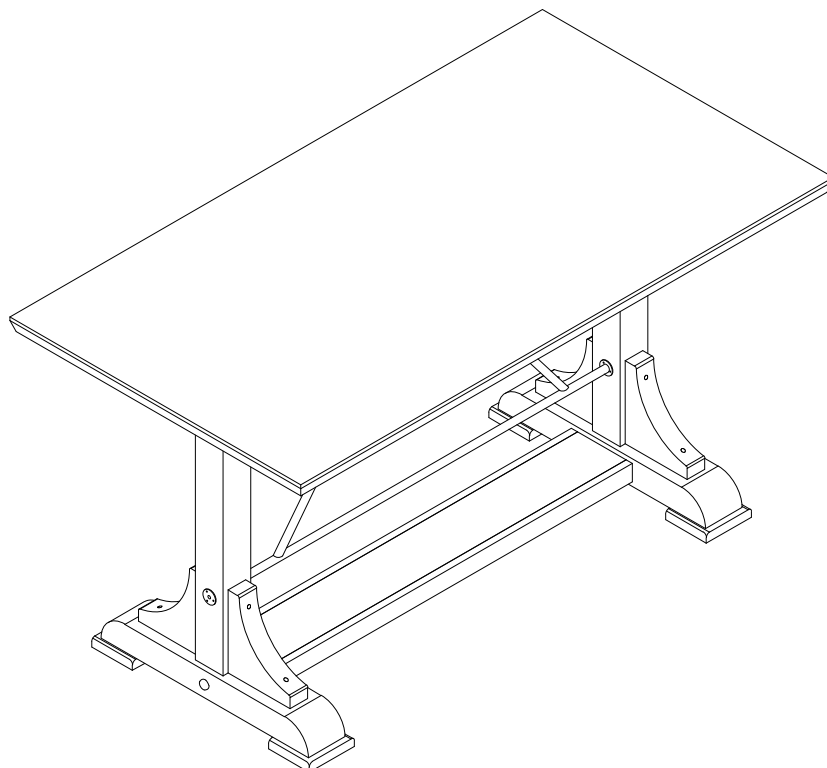

ITEM: **182438(B1&B2)**

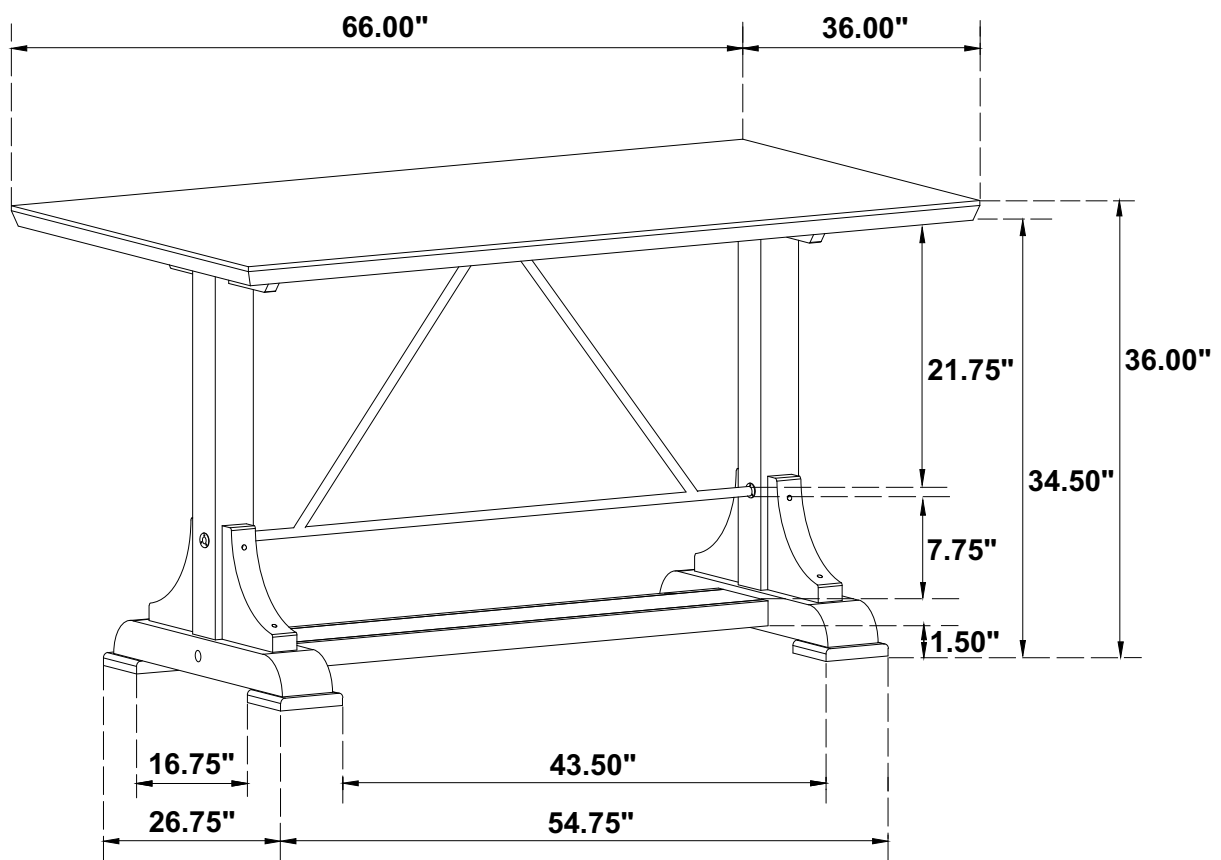

**Note : Dimension tolerance  $\pm 5\%$**

*ASSEMBLY INSTRUCTIONS*  
*COASTER FINE FURNITURE*

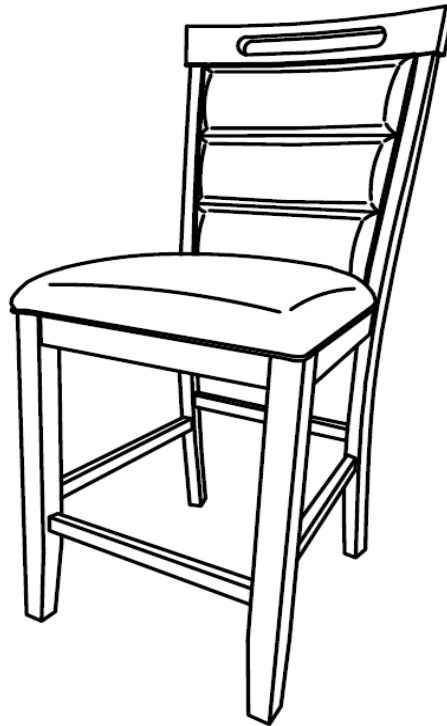

*Fine Furniture for every stage of life*

**193109**  
**Counter Height Chair**

ITEM: 193109



## ASSEMBLY INSTRUCTIONS

### ASSEMBLY TIPS:

1. Remove hardware from box and sort by size.
2. Please check to see that all hardware and parts are present prior to start of assembly.
3. Please follow attached instructions in the same sequence as numbered to assure fast & easy assembly.



### WARNING!



1. Don't attempt to repair or modify parts that are broken or defective. Please contact the store immediately.
2. This product is for home use only and not intended for commercial establishments.



ASSEMBLY TIME

15 MINUTES

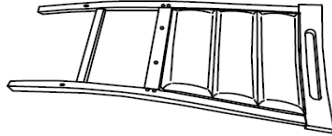
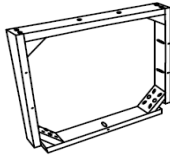
## PARTS IDENTIFICATION

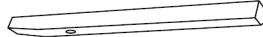
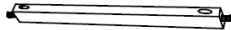
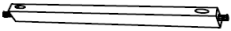
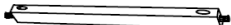
A	BACK FRAME		1PC
B	SEAT FRAME		1PC
C	SEAT CUSHION		1PC
D	LEFT FRONT LEG		1PC
E	RIGHT FRONT LEG		1PC
F	LEFT SIDE STRETCHER		1PC
G	RIGHT SIDE STRETCHER		1PC
H	FRONT STRETCHER		1PC

### NOTE:

Quantities shown are for one chair.

Phillips head screw driver is required in the assembly process; however, manufacturer does not provide this item.

## ASSEMBLY INSTRUCTIONS

### ASSEMBLY TIPS:







1. Remove hardware from box and sort by size.
2. Please check to see that all hardware and parts are present prior to start of assembly.
3. Please follow attached instructions in the same sequence as numbered to assure fast & easy assembly.

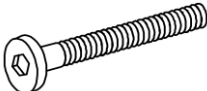

### WARNING!

1. Don't attempt to repair or modify parts that are broken or defective. Please contact the store immediately.
2. This product is for home use only and not intended for commercial establishments.

## HARDWARE IDENTIFICATION

1	<b>ALLEN WRENCH</b> (M4 - BLK)		1PC
2	<b>SHORT BOLT</b> (M6 x 40mm - RBW)		2PCS
3	<b>MEDIUM BOLT</b> (M6 x 60mm - RBW)		4PCS
4	<b>LONG BOLT</b> (M6 x 70mm - RBW)		4PCS
5	<b>LOCK WASHER</b> (M6 - RBW)		10PCS
6	<b>FLAT WASHER</b> (M6 - RBW)		10PCS
7	<b>SHORT FLAT HEAD SCREW</b> (M4 x 25mm- RBW)		5PCS
8	<b>LONG FLAT HEAD SCREW</b> (M4 x 38mm- RBW)		6PCS

### NOTE:

Quantities shown are for one chair.

Phillips head screw driver is required in the assembly process; however, manufacturer does not provide this item.

ITEM: **193109**

**ASSEMBLY INSTRUCTIONS**  
**STEP 1**

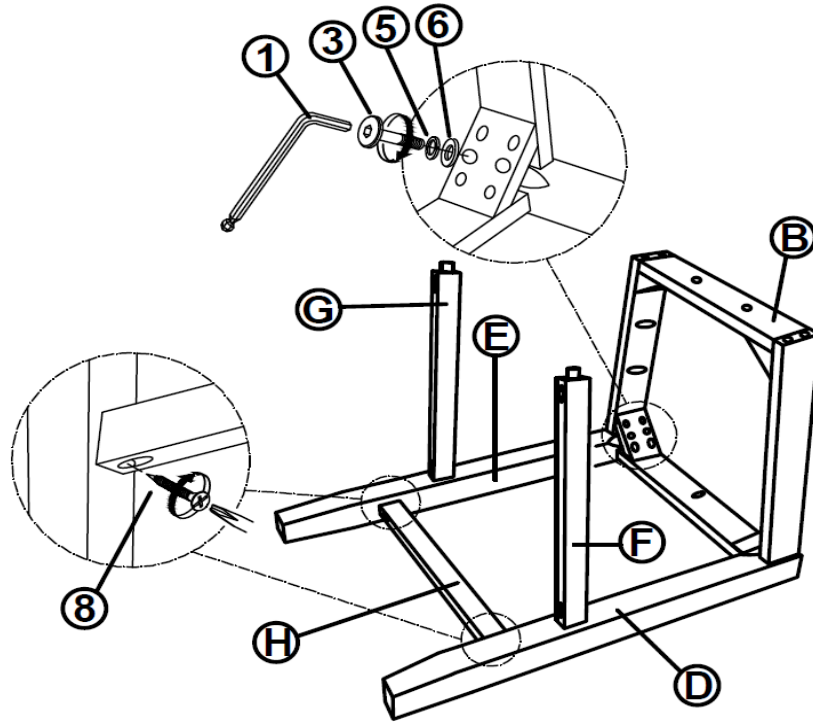

**STEP 2**

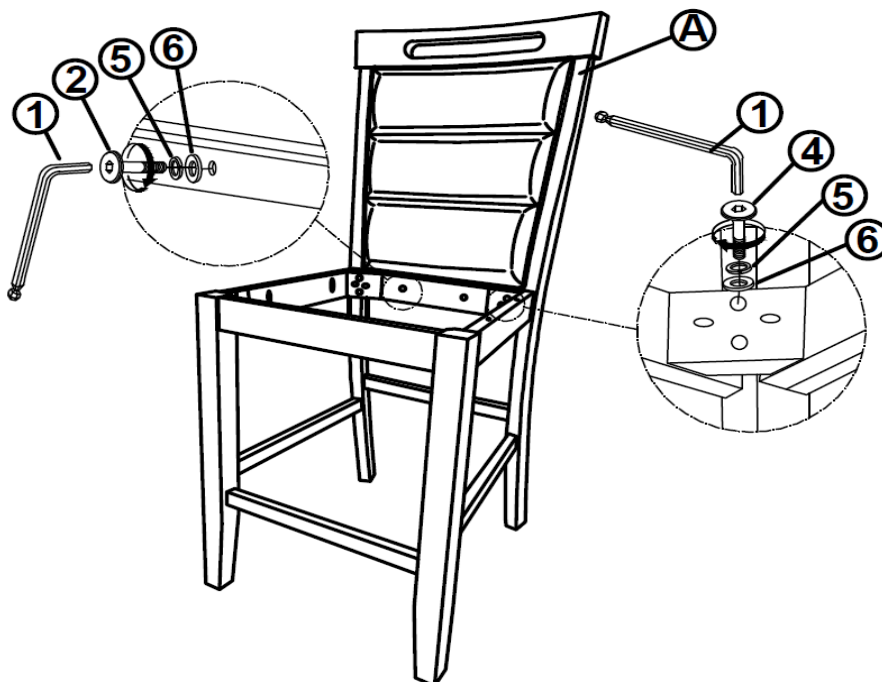

ITEM: **193109**



**ASSEMBLY INSTRUCTIONS**  
**STEP 3**

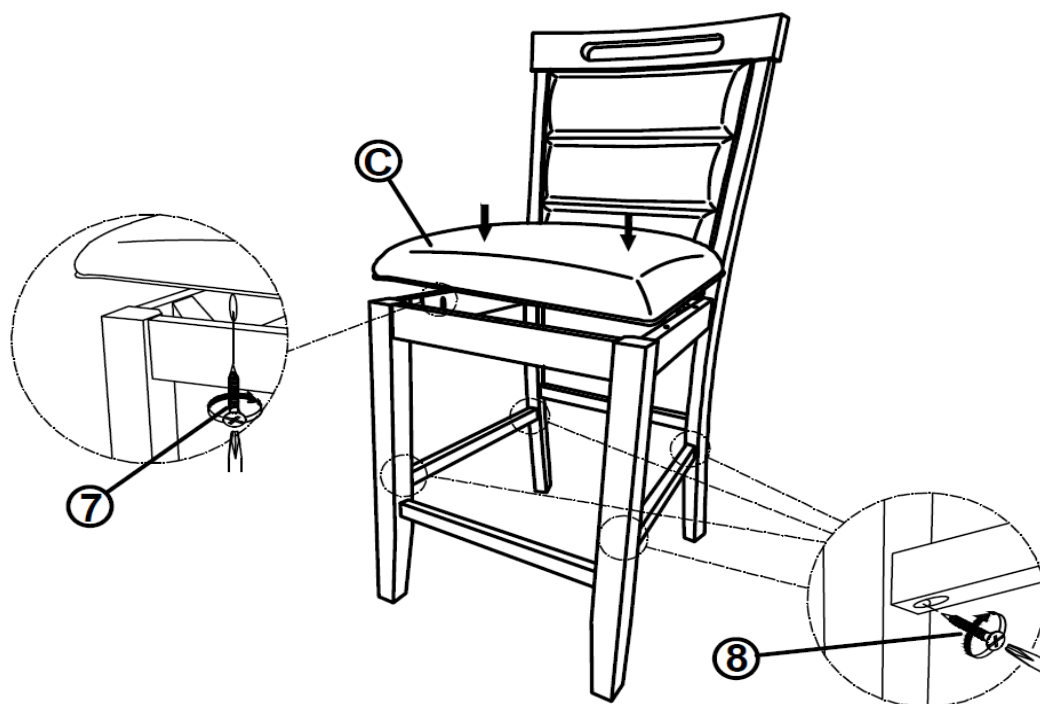

**STEP 4**  
**COMPLETE**

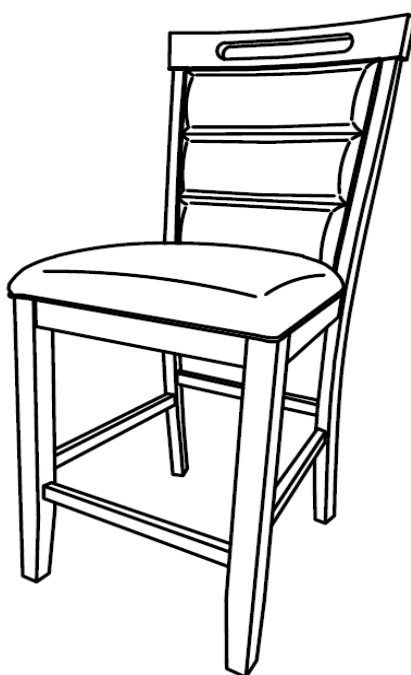

ITEM: 193109

**COASTER**  
FINE FURNITURE

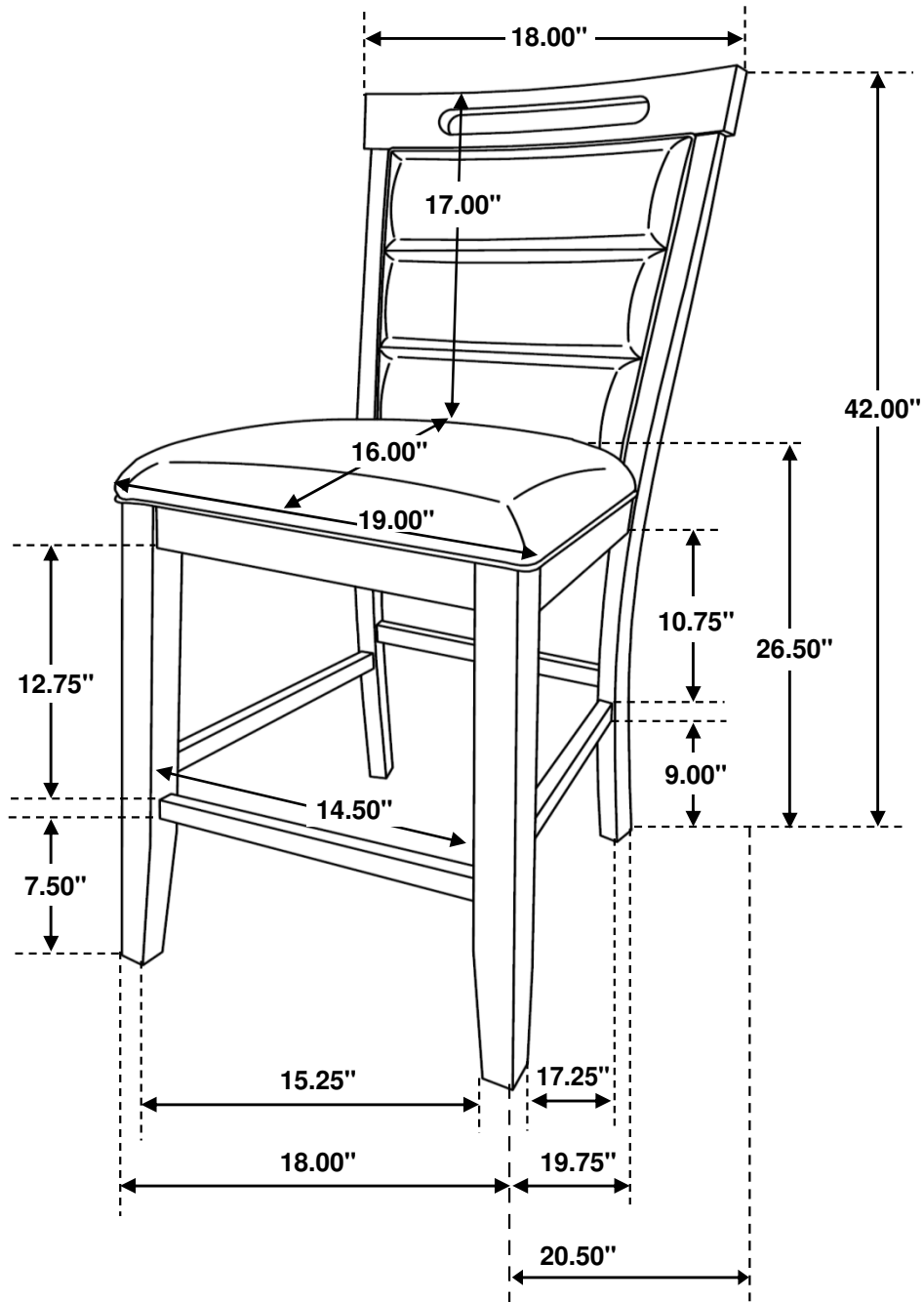

**Note: Dimension tolerance  $\pm 5\%$**