

ASSEMBLY INSTRUCTIONS
COASTER FINE FURNITURE



Fine Furniture for every stage of life

193830(B1&B2)
Dining Table

ITEM: 193830(B1&B2)



ASSEMBLY INSTRUCTIONS

ASSEMBLY TIPS:

1. Remove hardware from box and sort by size.
2. Please check to see that all hardware and parts are present prior to start of assembly.
3. Please follow attached instructions in the same sequence as numbered to assure fast & easy assembly.



WARNING!

1. Don't attempt to repair or modify parts that are broken or defective. Please contact the store immediately.
2. This product is for home use only and not intended for commercial establishments.



ASSEMBLY TIME

15 MINUTES

PARTS IDENTIFICATION

B1 (BOX 1)

A TOP

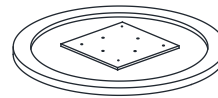

1PC

B MOUNTING PLATE
(PRE-ATTACHED TO TOP)

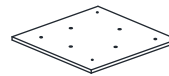

1PC

B2 (BOX 2)

C LEG WITH LABEL "1" (L)



1PC

D LEG WITH LABEL "1" (R)



1PC

E LEG WITH LABEL "2" (L)



1PC

F LEG WITH LABEL "2" (R)



1PC

HARDWARE IDENTIFICATION

Z-B1 (BOX 1) - HARDWARE PACK IS LOCATED IN 193830 (B1)

1 ALLEN WRENCH
(M4 X 60MM - RBW)



1PC

2 BOLT
(M6 X 30MM - RBW)



4PCS

3 LOCK WASHER
(M6 X 13MM - RBW)



4PCS

4 FLAT WASHER
(M6 X 13MM - RBW)



4PCS

5 WOOD DOWEL
(M8 X 30MM)



14PCS

6 LEVELER
(M6 X 23MM)



8PCS

ITEM: 193830(B1&B2)



ASSEMBLY INSTRUCTIONS

STEP 1

Attention! Please remove part B and all hardware from TOP (A), using ALLEN WRENCH (1) and keep for STEP 8 and STEP 9.

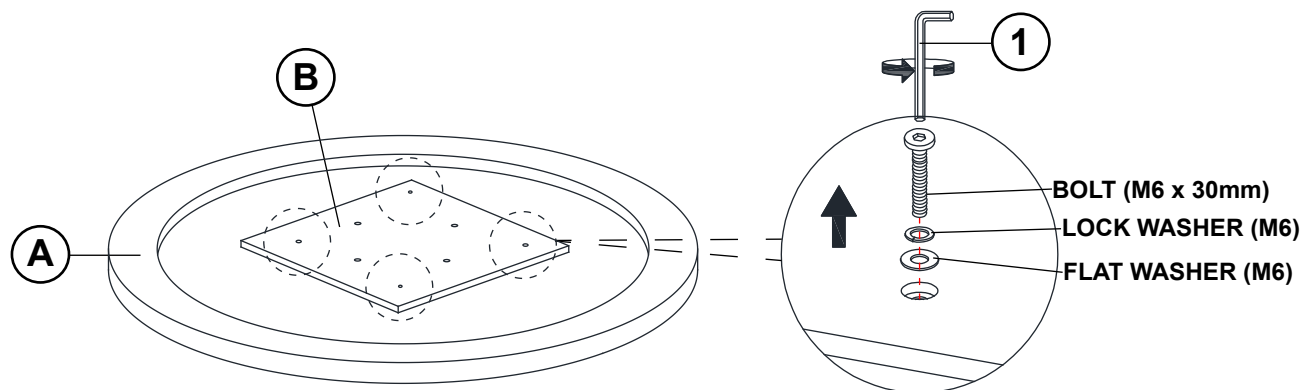

STEP 2

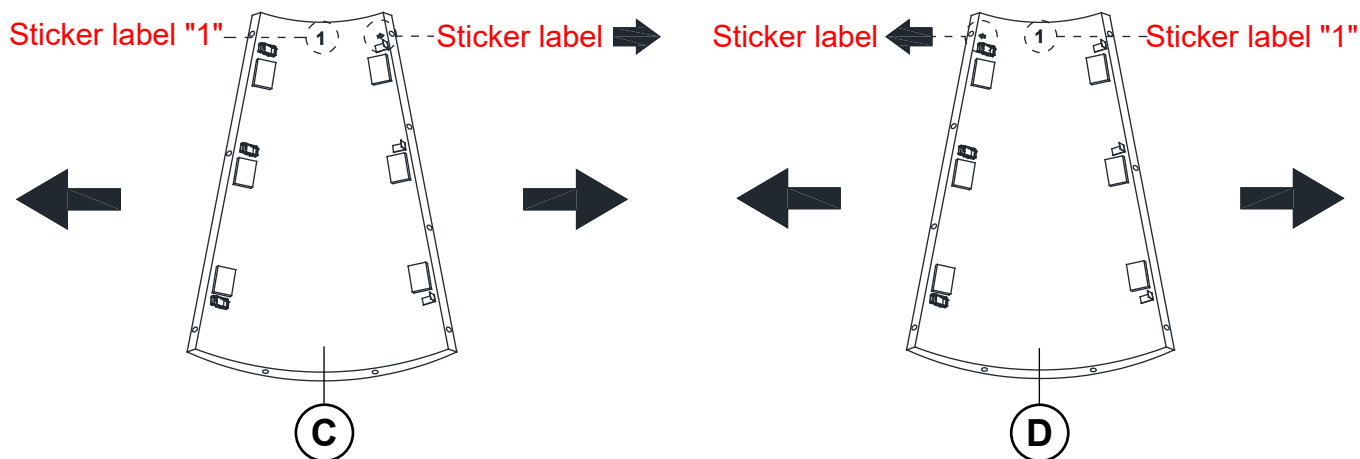

STEP 3

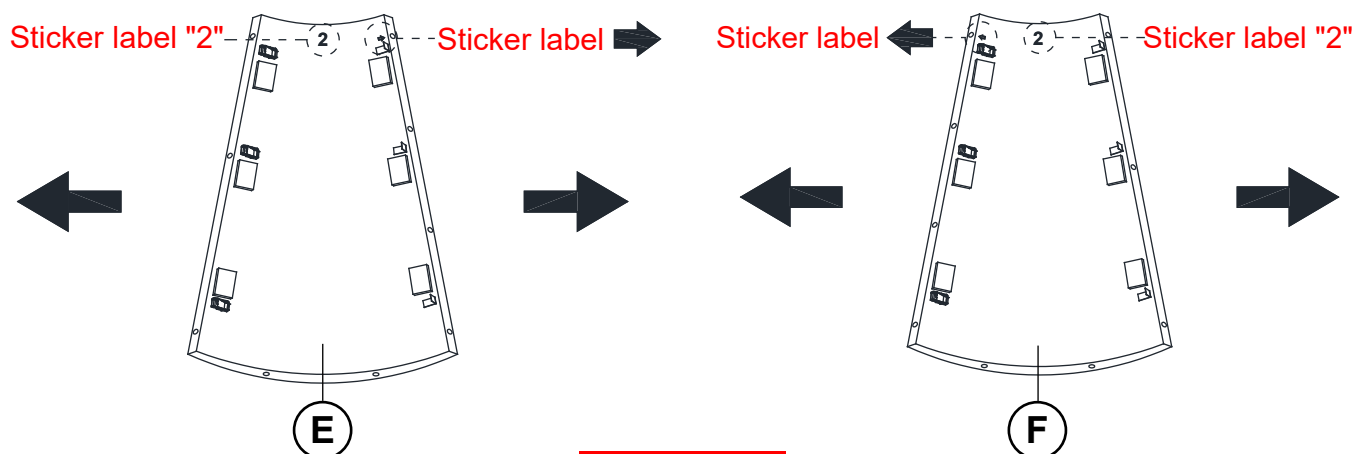

ITEM: **193830(B1&B2)**

ASSEMBLY INSTRUCTIONS



STEP 4

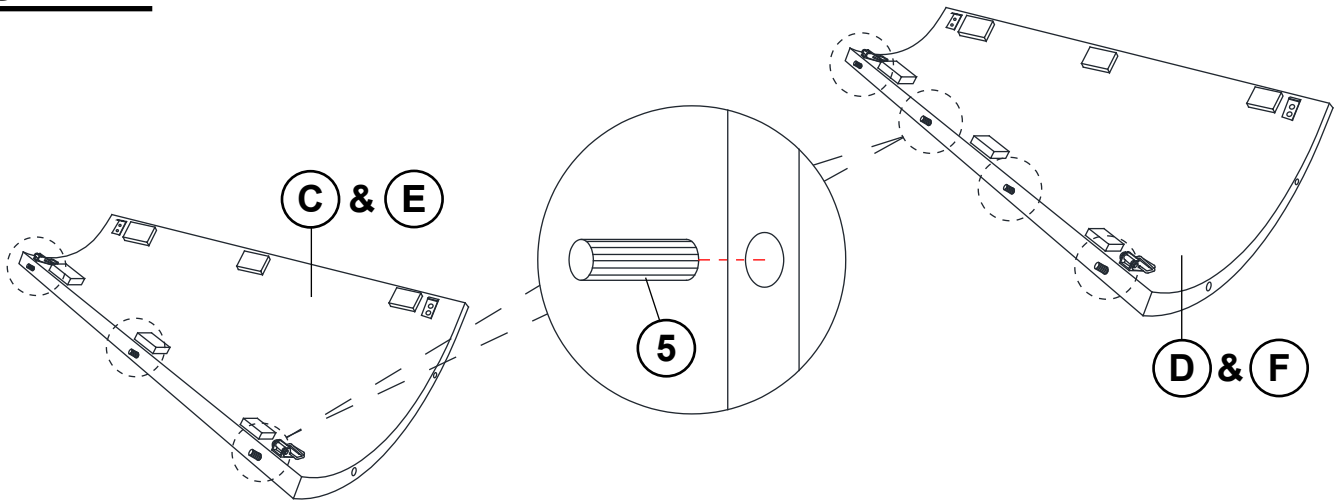

STEP 5

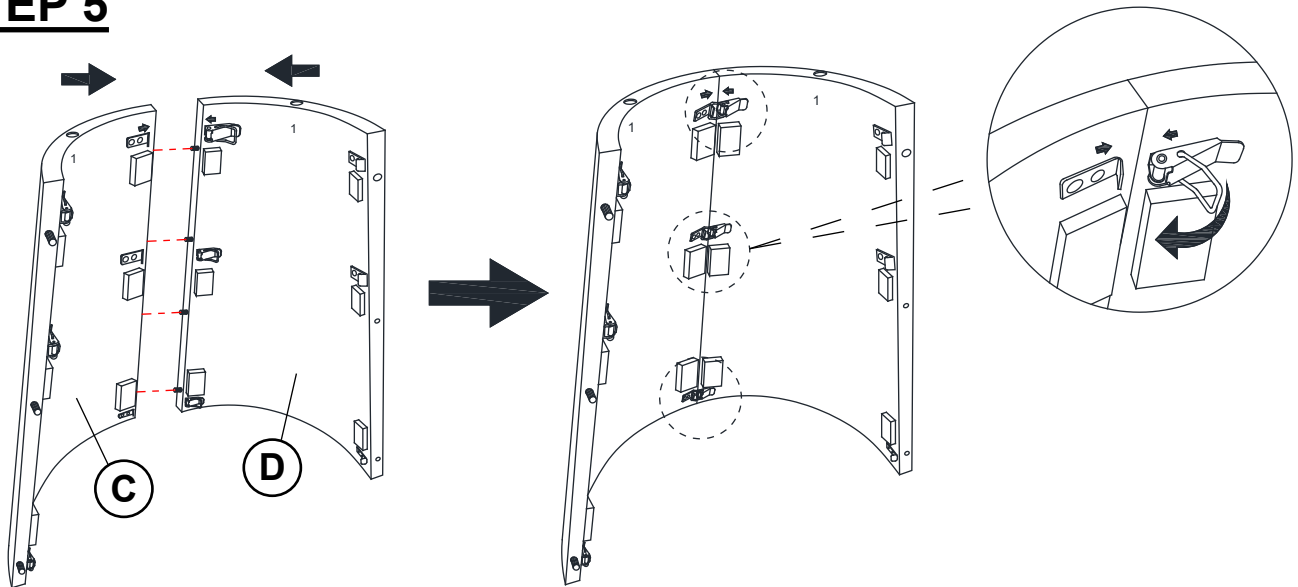

STEP 6

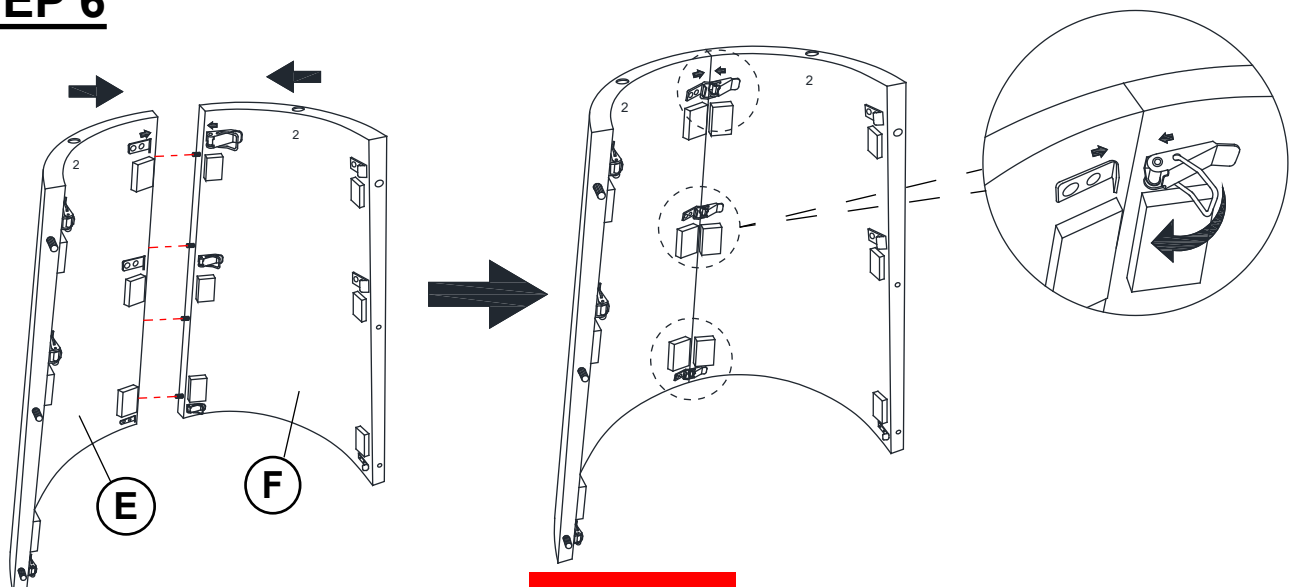

ITEM: 193830(B1&B2)

ASSEMBLY INSTRUCTIONS



STEP 7

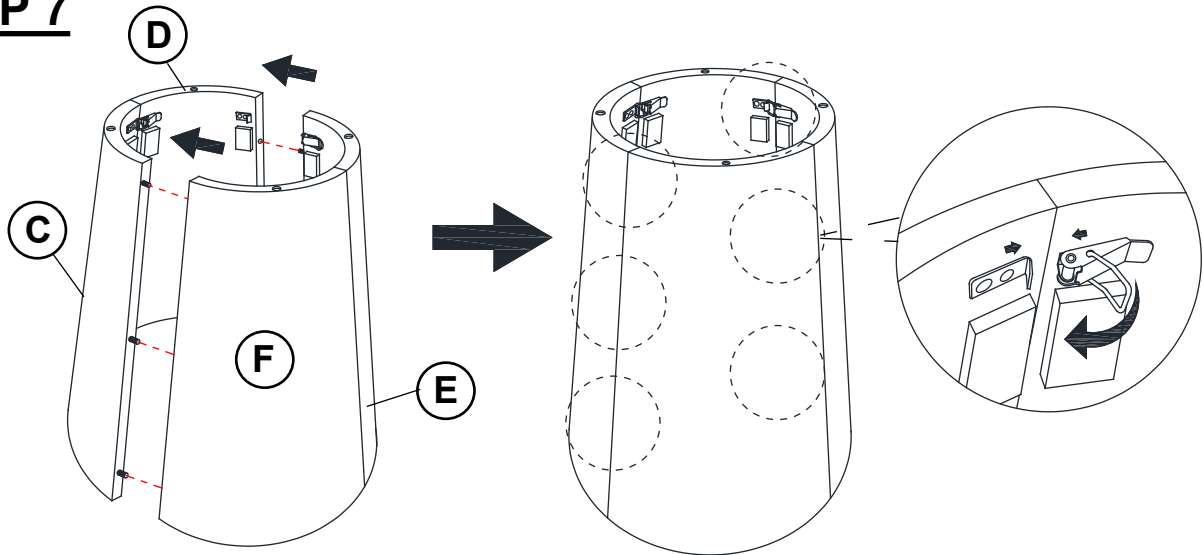

STEP 8

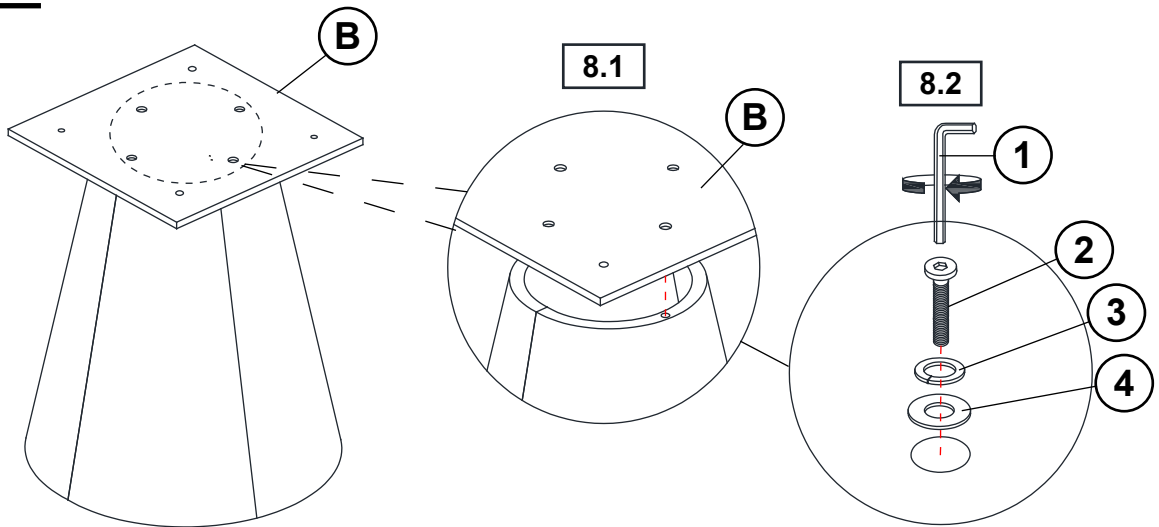

STEP 9

Attention! Use hardware from STEP 1 for this STEP.

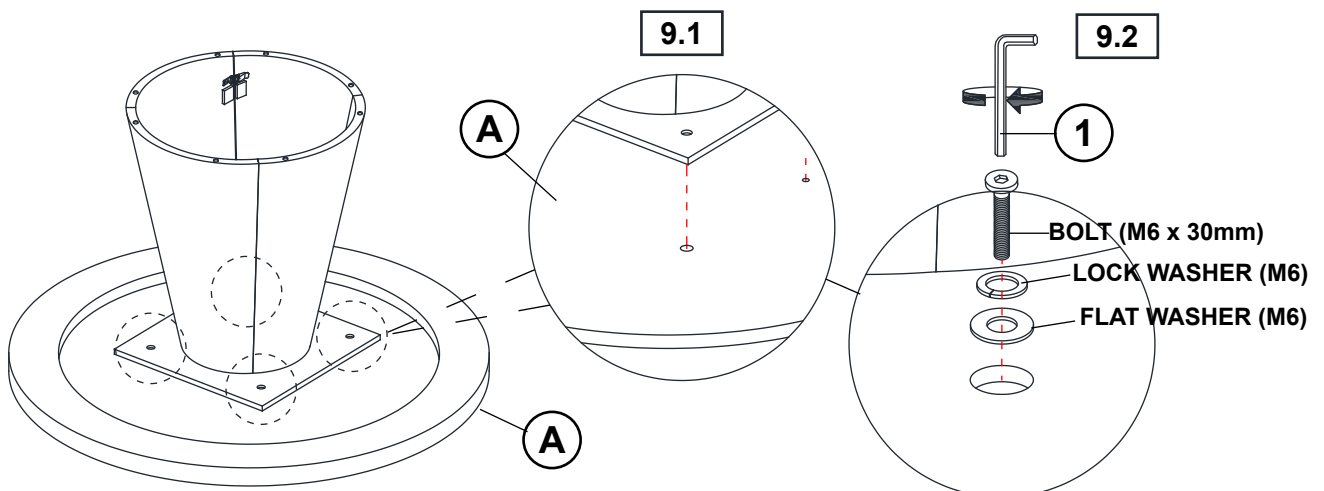

*BOTTOM VIEW

ITEM: **193830(B1&B2)**

ASSEMBLY INSTRUCTIONS

STEP 10

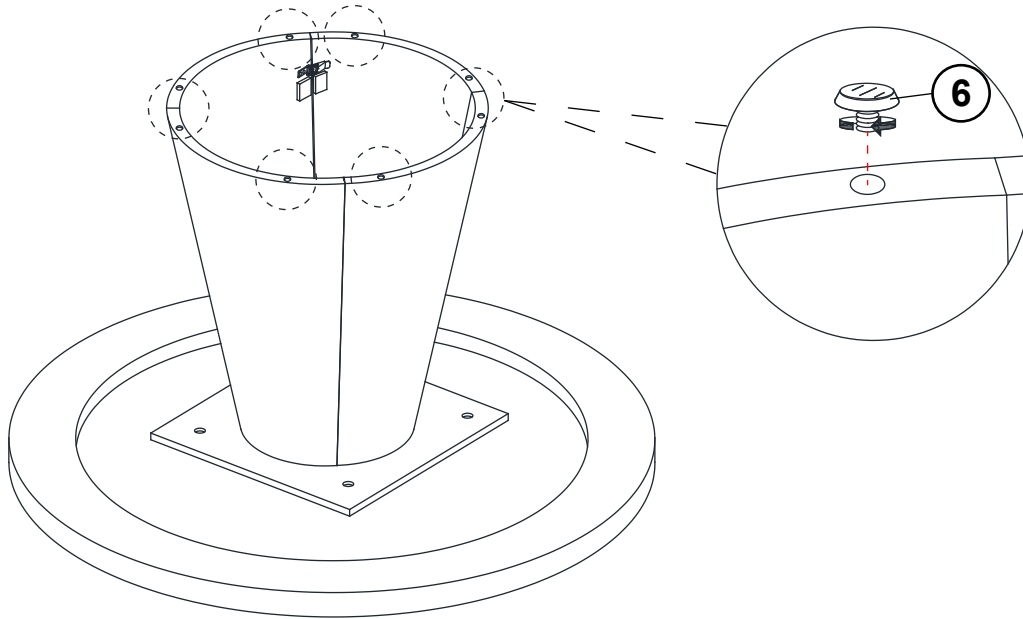

STEP 11
COMPLETE

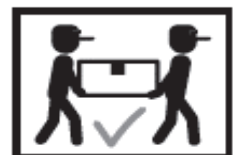
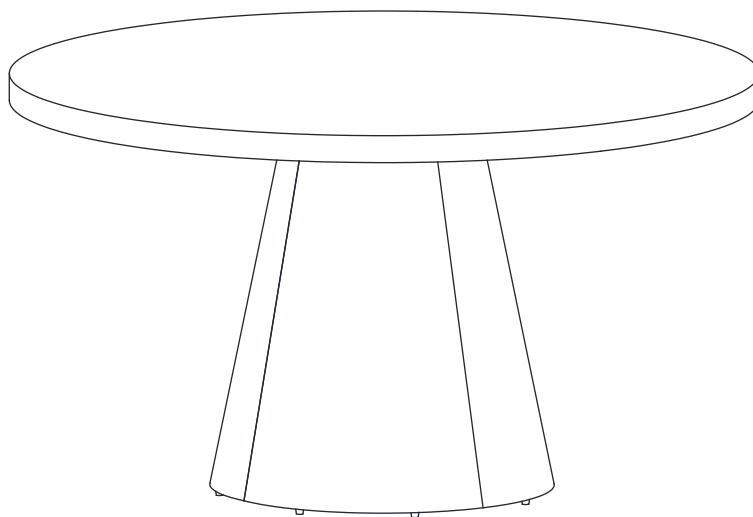

ITEM: **193830(B1&B2)**

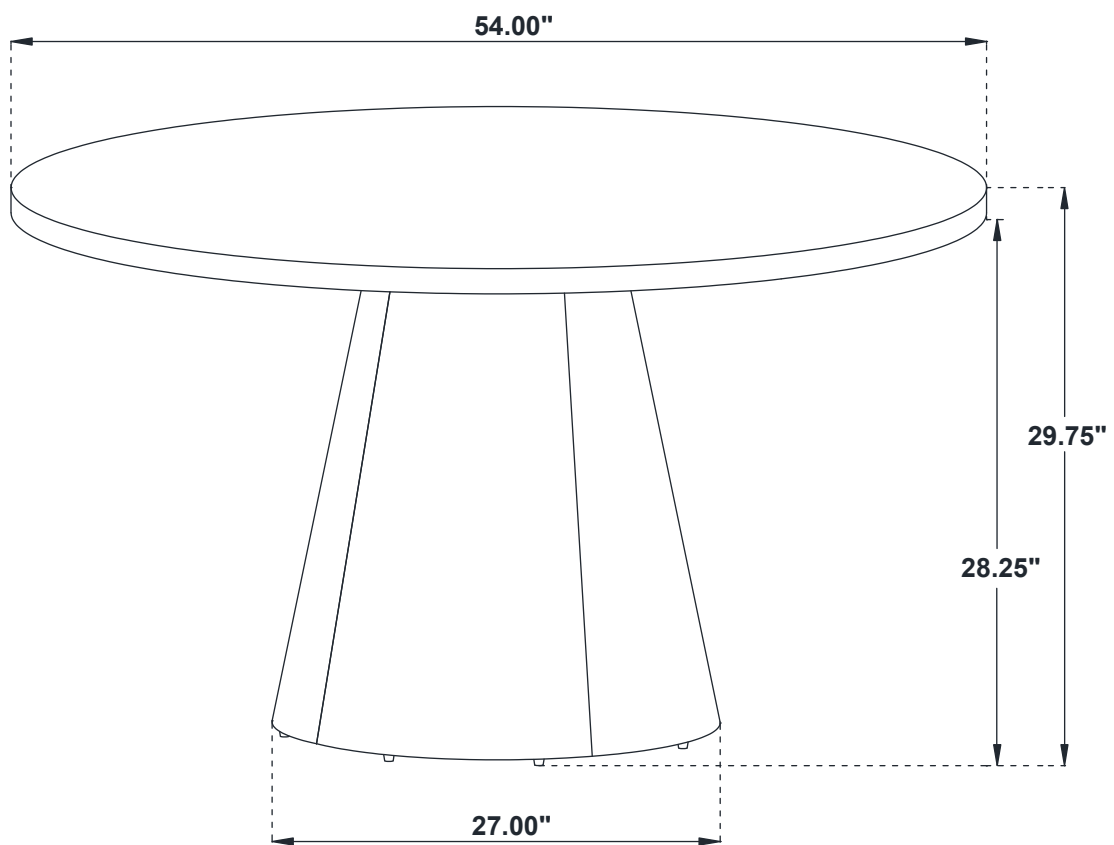

Note: Dimension tolerance $\pm 5\%$

ASSEMBLY INSTRUCTIONS
COASTER FINE FURNITURE



Fine Furniture for every stage of life

193832
Side Chair

ITEM: 193832



ASSEMBLY INSTRUCTIONS

ASSEMBLY TIPS:

1. Remove hardware from box and sort by size.
2. Please check to see that all hardware and parts are present prior to start of assembly.
3. Please follow attached instructions in the same sequence as numbered to assure fast & easy assembly.



WARNING!

1. Don't attempt to repair or modify parts that are broken or defective. Please contact the store immediately.
2. This product is for home use only and not intended for commercial establishments.



ASSEMBLY TIME

15 MINUTES

PARTS IDENTIFICATION

A	BACKREST		1PC
B	LEFT LEG		1PC
C	RIGHT LEG		1PC
D	FRONT RAIL		1PC
E	BACK RAIL (MARKING HOLE)		1PC
F	SEAT		1PC

HARDWARE IDENTIFICATION

1	ALLEN WRENCH (M4 X 100MM - RBW)		1PC
2	LONG BOLT (M6 X 60MM - RBW)		6PCS
3	SHORT BOLT (M6 X 30MM - RBW)		4PCS
4	LOCK WASHER (M6 X 13MM - RBW)		10PCS
5	FLAT WASHER (M6 X 13MM - RBW)		10PCS
6	FLAT HEAD SCREW (M4 X 30MM)		4PCS
7	BIG WOOD DOWEL (M8 X 30MM)		4PCS
8	SMALL WOOD DOWEL (M8 X 25MM)		1PC
9	WOOD BUTTON (14.5MM)		4PCS
10	FELT PAD (3 X 21MM)		4PCS

NOTE :

Phillips head screw driver is required in the assembly process; however, manufacturer does not provide this item. Quantities shown are for one chair.

ITEM: **193832**

ASSEMBLY INSTRUCTIONS



STEP 1

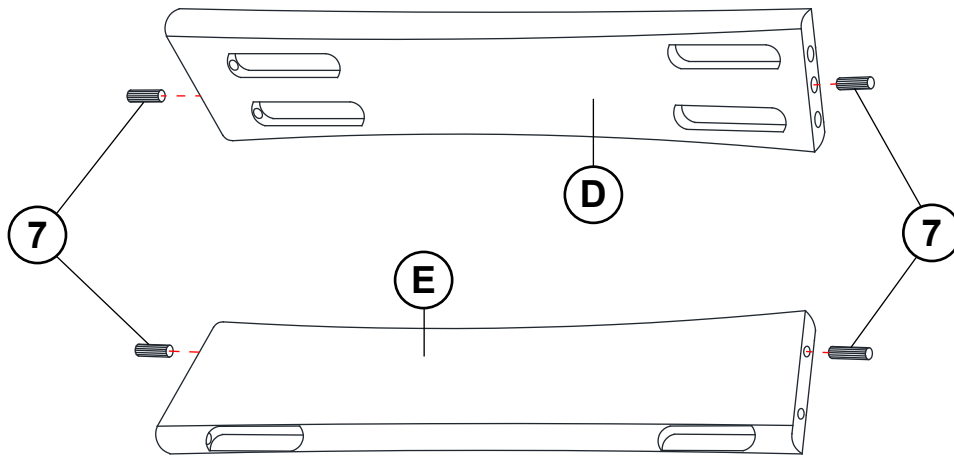

STEP 2

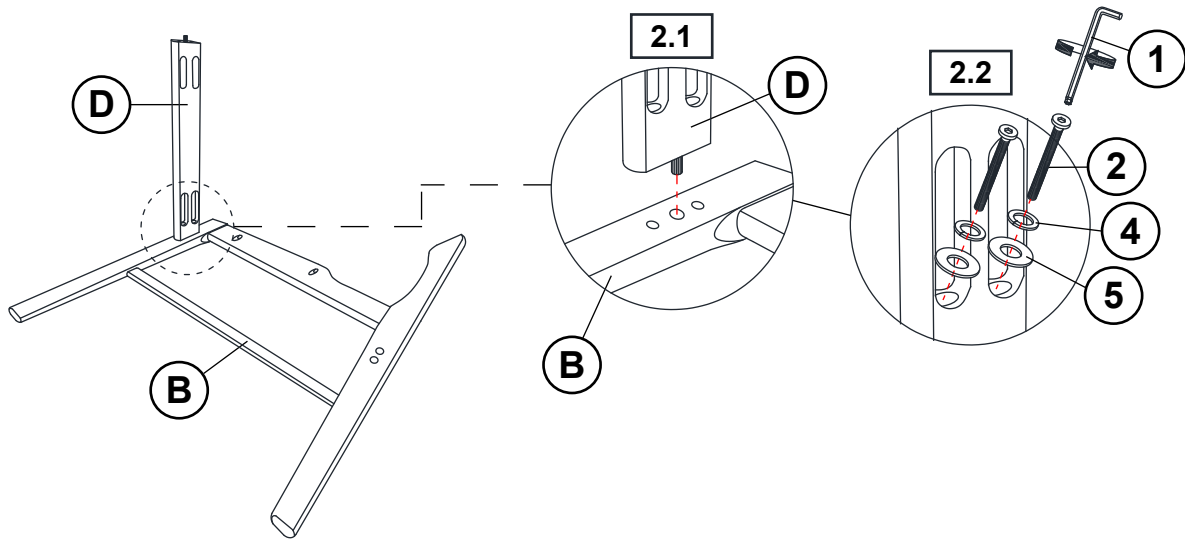

STEP 3

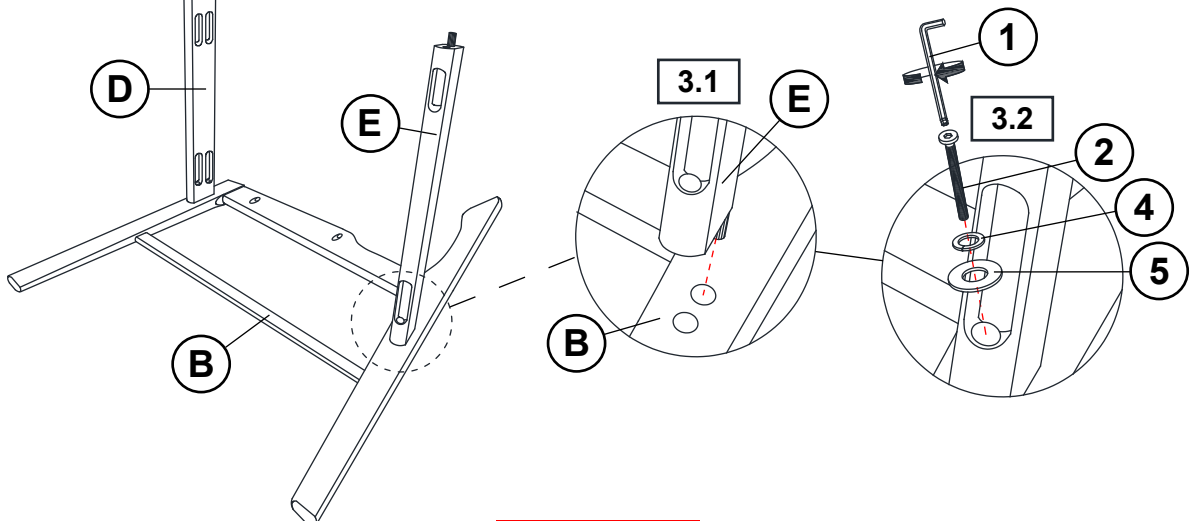

ITEM: **193832**

ASSEMBLY INSTRUCTIONS



STEP 4

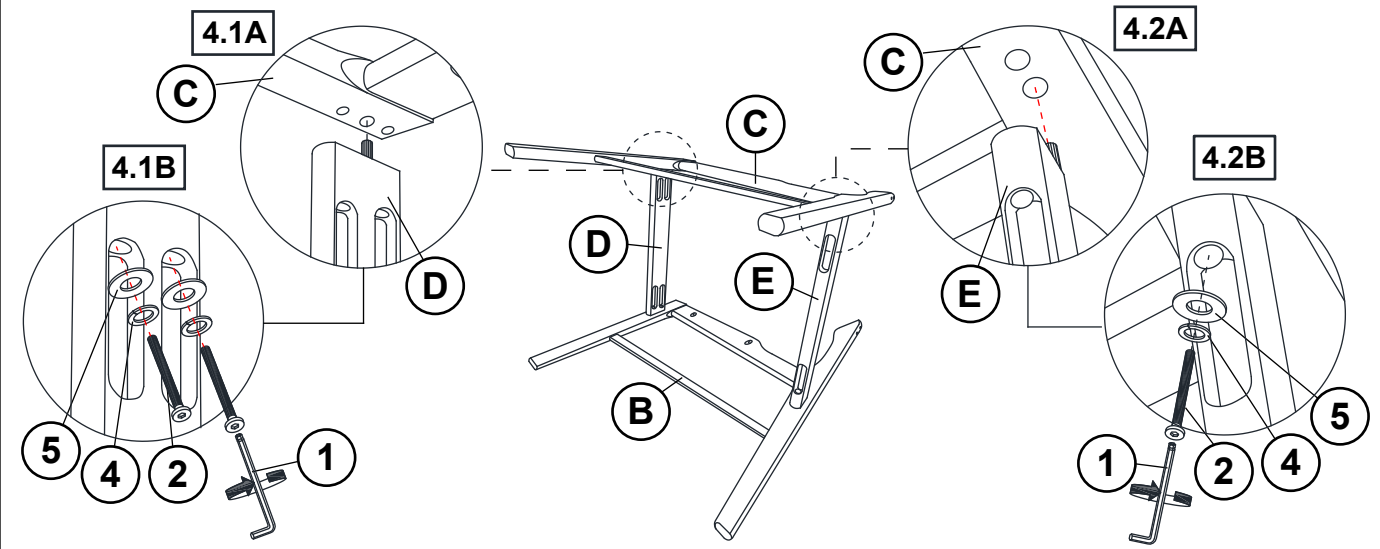

STEP 5

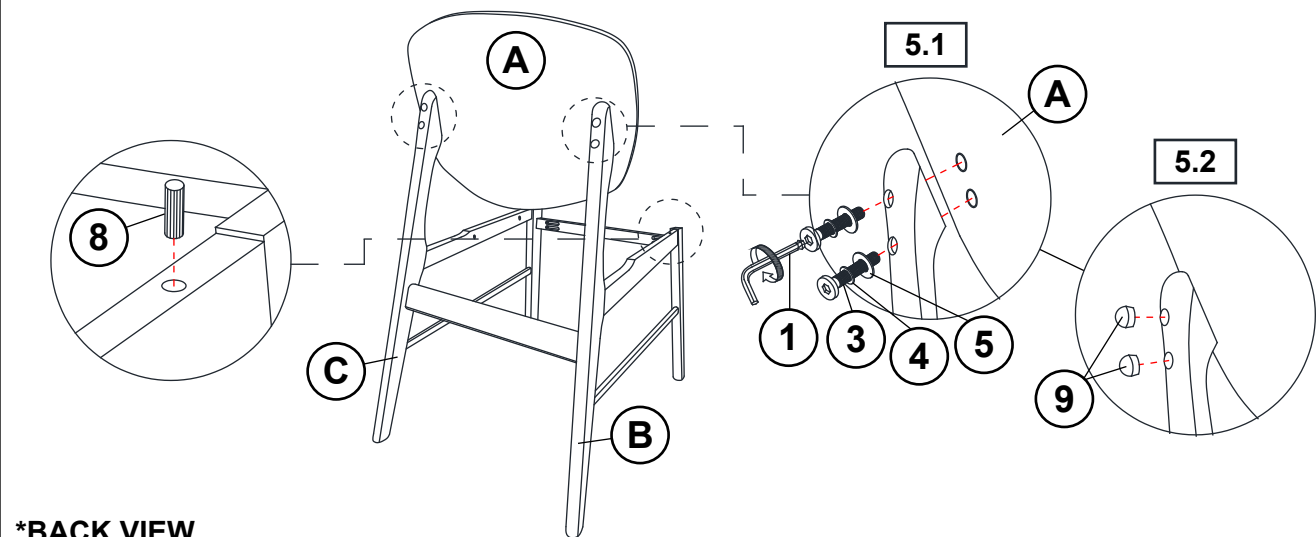

*BACK VIEW

STEP 6

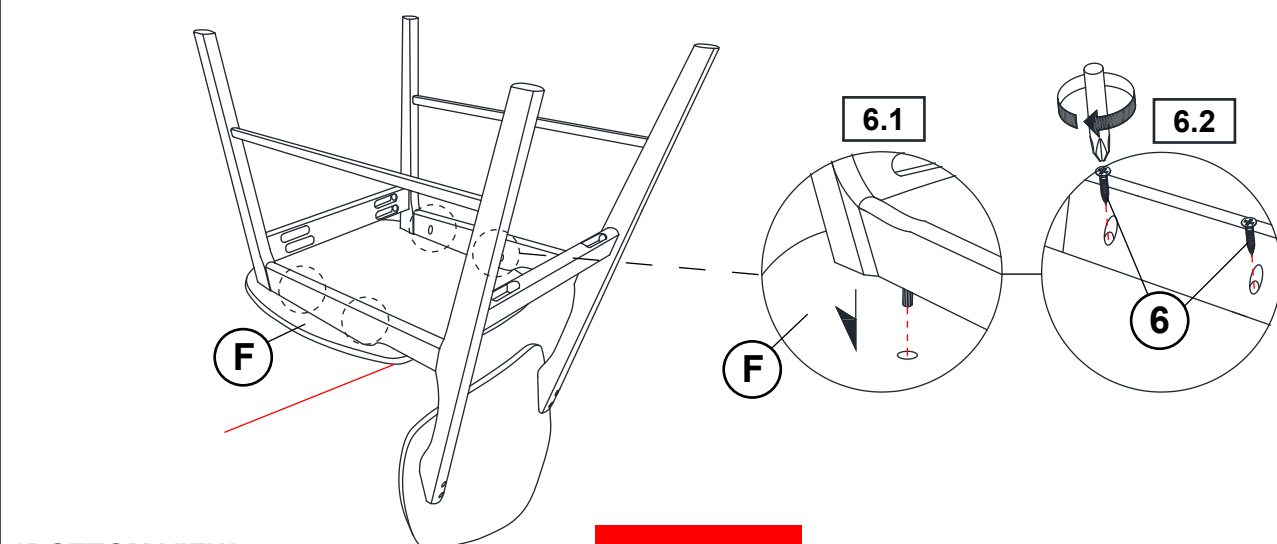

*BOTTOM VIEW

ITEM: **193832**

ASSEMBLY INSTRUCTIONS

STEP 7

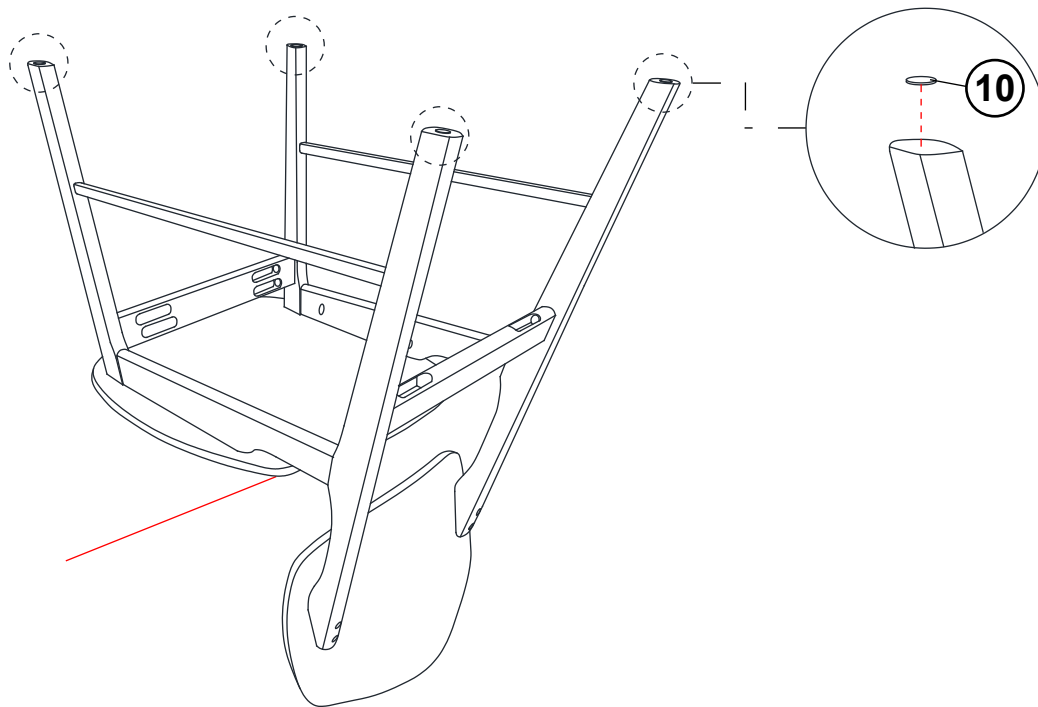

*BOTTOM VIEW

STEP 8
COMPLETE

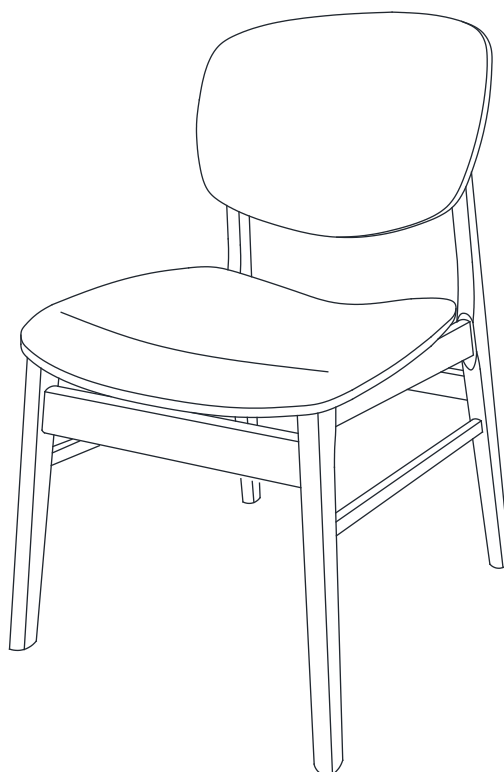

ITEM: 193832

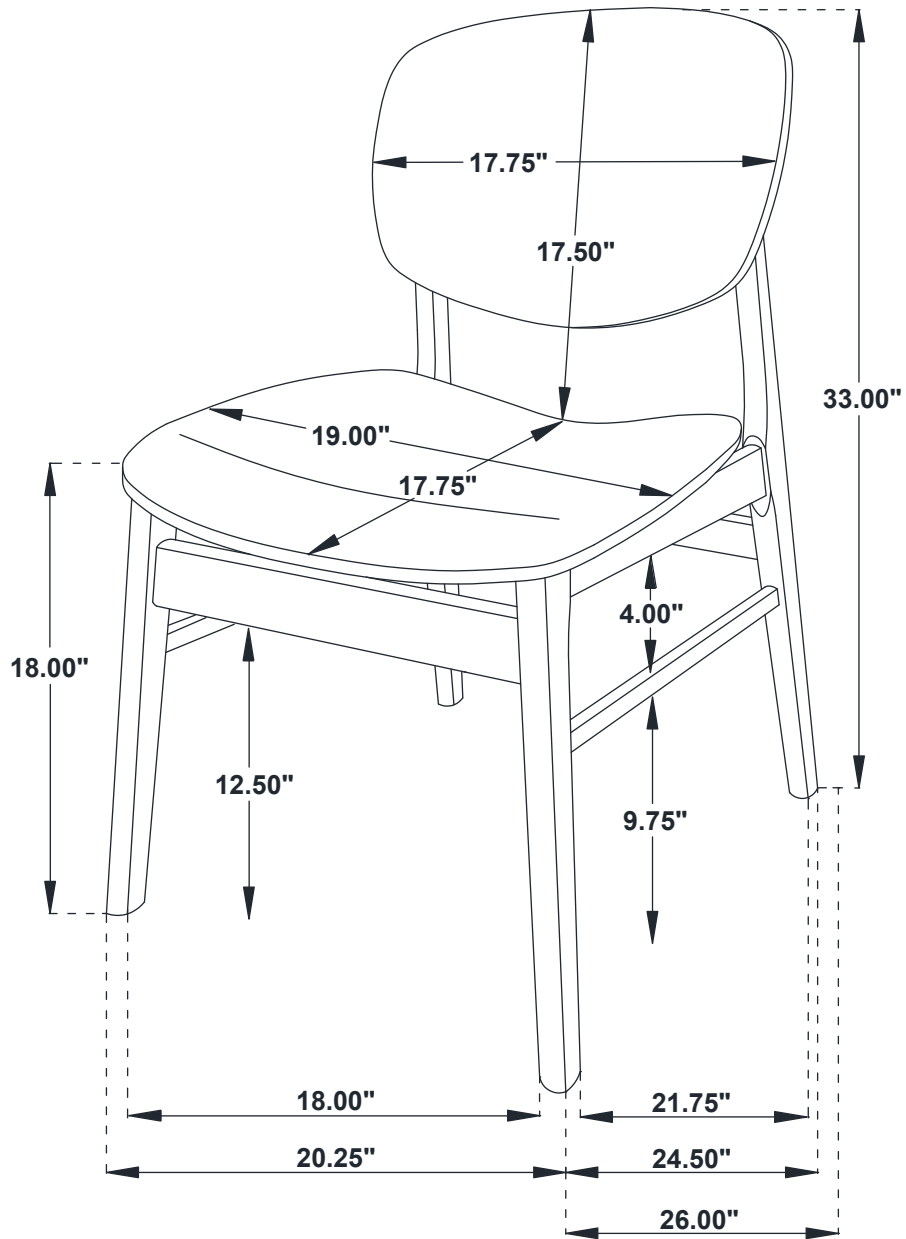

Note: Dimension tolerance $\pm 5\%$