



*ASSEMBLY INSTRUCTIONS*  
*COASTER FINE FURNITURE*



*Fine Furniture for every stage of life*

**193912WHT**  
**Side Chair**

# ITEM: 193912WHT

## ASSEMBLY INSTRUCTIONS



### ASSEMBLY TIPS:

1. Remove hardware from box and sort by size.
2. Please check to see that all hardware and parts are present prior to start of assembly.
3. Please follow attached instructions in the same sequence as numbered to assure fast & easy assembly.



### WARNING!

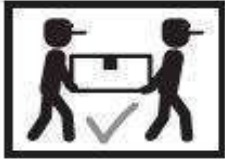

1. Don't attempt to repair or modify parts that are broken or defective. Please contact the store immediately.
2. This product is for home use only and not intended for commercial establishments.







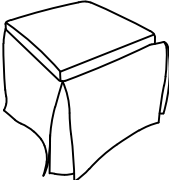

ASSEMBLY TIME

30 MINUTES

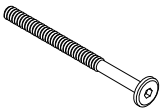
## PARTS IDENTIFICATION

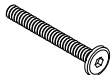
A	BACKREST		1PC	C	FRONT LEG		2PCS
B	SEAT		1PC				

## HARDWARE IDENTIFICATION

1	LONG BOLT (Ø5/16" x 80mm - RBW)		4PCS	4	LOCK WASHER (Ø5/16" x 12mm - RBW)		10PCS
2	MEDIUM BOLT (Ø5/16" x 50mm - RBW)		4PCS	5	FLAT WASHER (Ø5/16" x 16mm - RBW)		10PCS
3	SHORT BOLT (Ø5/16" x 40mm - RBW)		2PCS	6	ALLEN WRENCH (M5 x 65mm - RBW)		1PC

ITEM: **193912WHT**  
ASSEMBLY INSTRUCTIONS

**STEP 1**

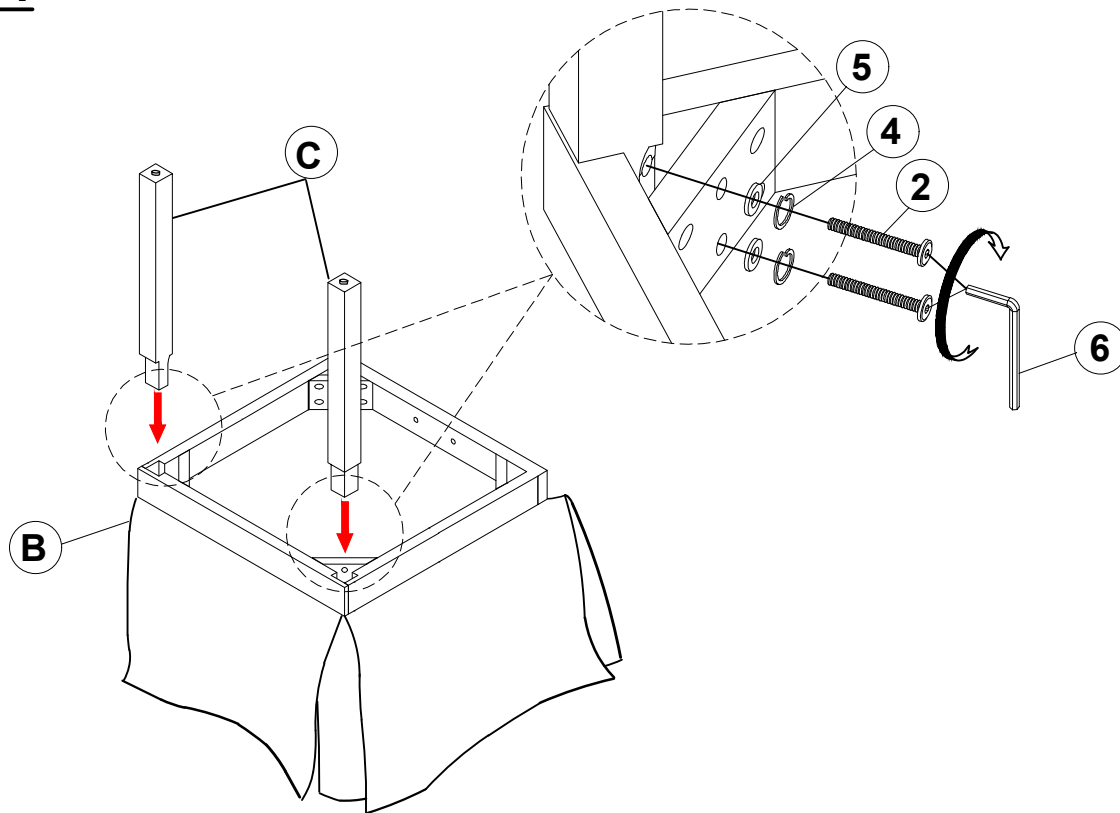

**STEP 2**

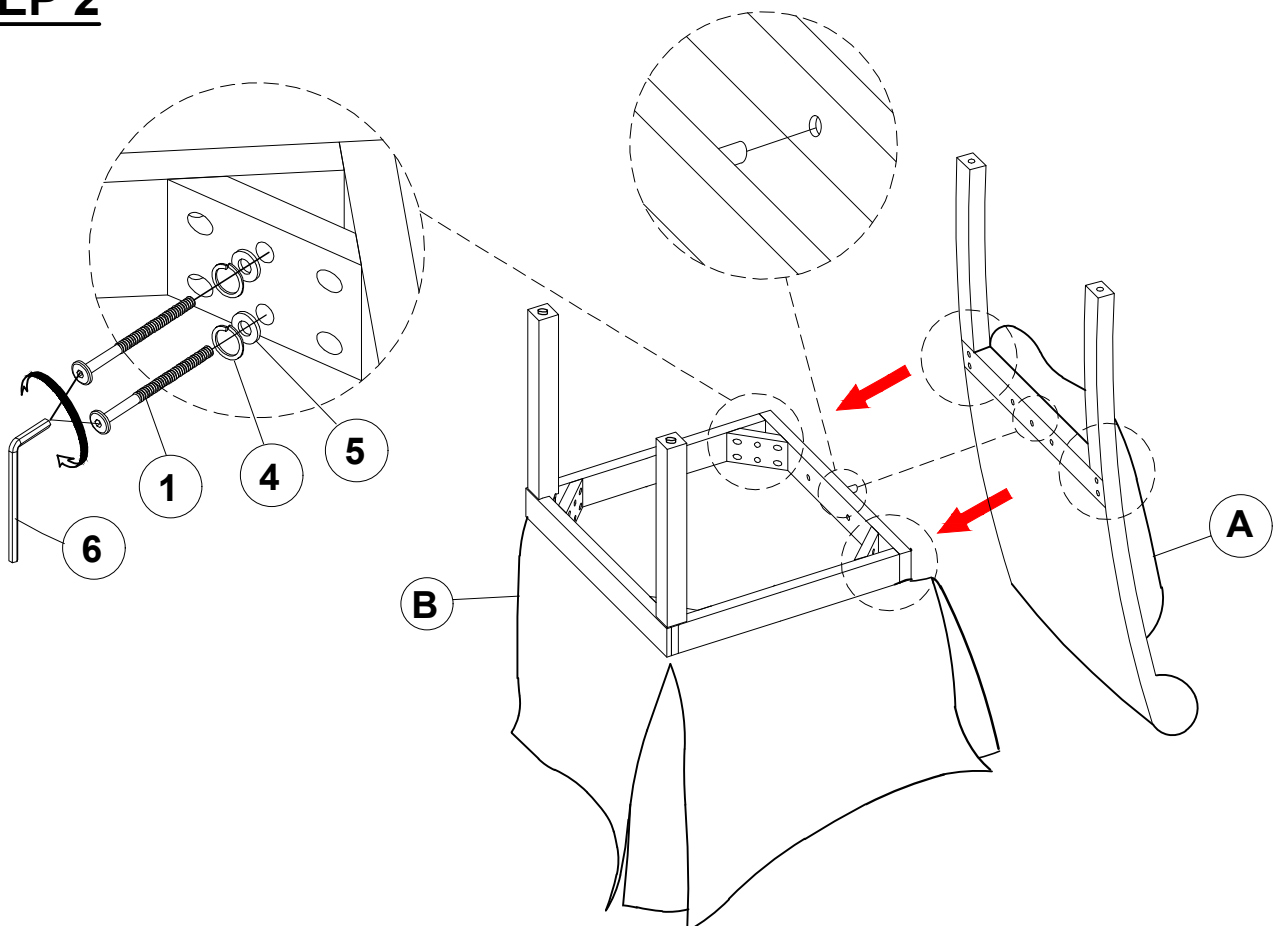

ITEM: **193912WHT**  
**ASSEMBLY INSTRUCTIONS**  
**STEP 3**

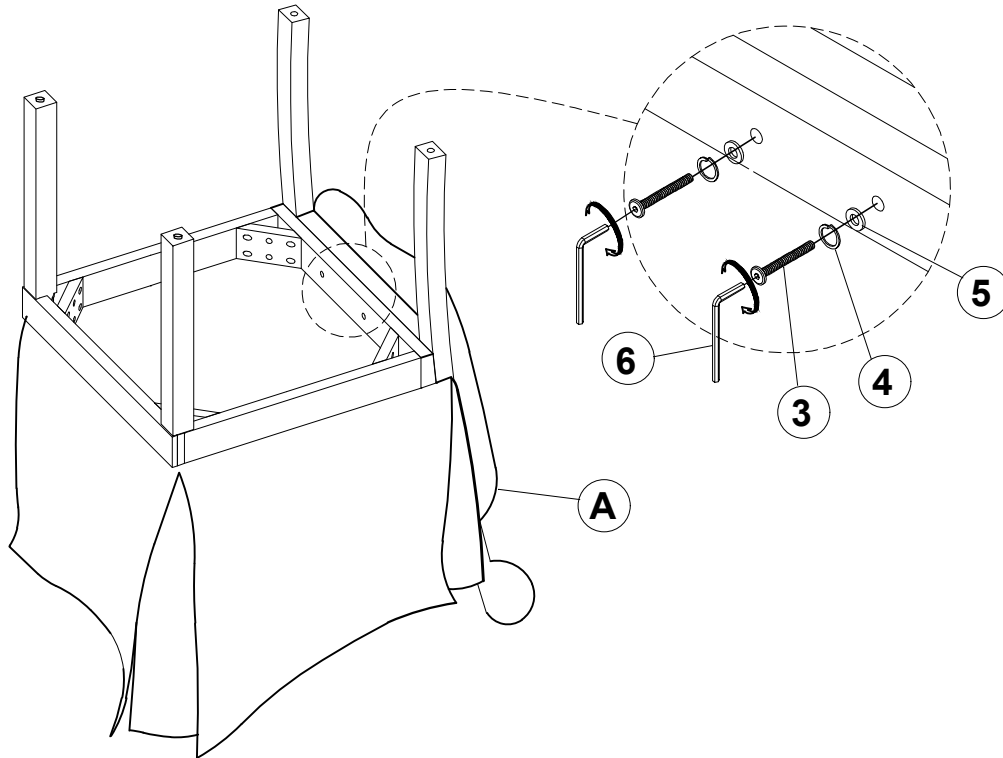

**STEP 4**  
**COMPLETE**

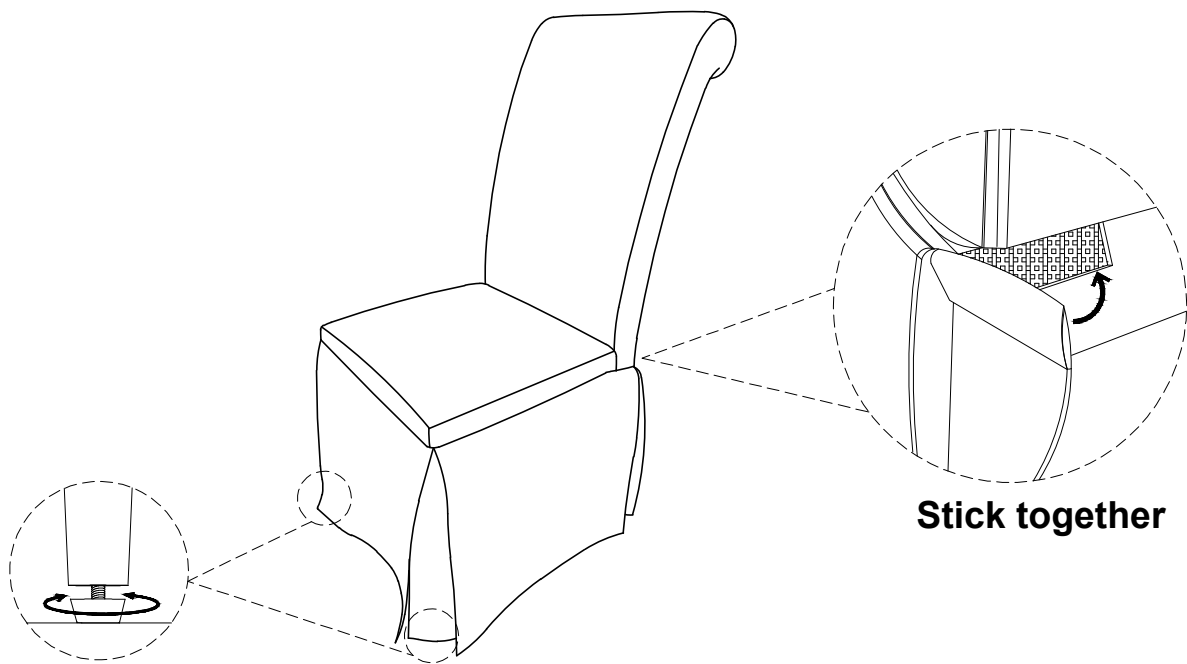

ITEM: 193912WHT

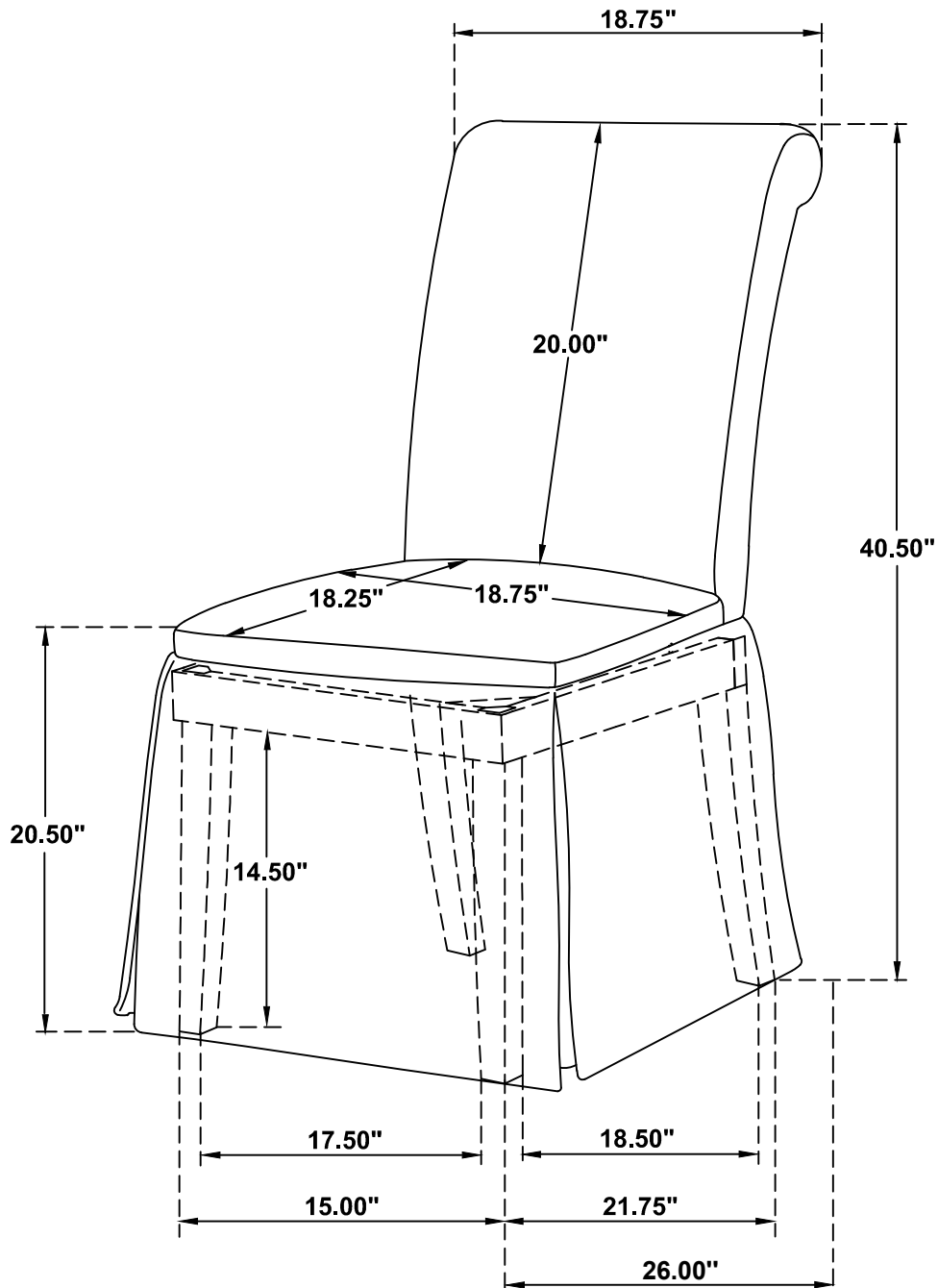

Note: Dimension tolerance  $\pm 5\%$