

ASSEMBLY INSTRUCTIONS
COASTER FINE FURNITURE



Fine Furniture for every stage of life

193930NAT
Dining Table

ITEM: 193930NAT

ASSEMBLY INSTRUCTIONS



ASSEMBLY TIPS:

1. Remove hardware from box and sort by size.
2. Please check to see that all hardware and parts are present prior to start of assembly.
3. Please follow attached instructions in the same sequence as numbered to assure fast & easy assembly.



WARNING!



1. Don't attempt to repair or modify parts that are broken or defective. Please contact the store immediately.
2. This product is for home use only and not intended for commercial establishments.





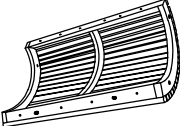

ASSEMBLY TIME

20 MINUTES

PARTS IDENTIFICATION

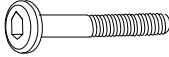
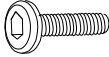
A	TOP		1PC
B	MOUNTING PLATE (PRE-ATTACHED TO TOP)		1PC
C	LEG		3PCS

HARDWARE IDENTIFICATION

1	ALLEN WRENCH (M4 x 63mm - BLK)		1PC
2	LONG BOLT (M6 x 50mm - RBW)		12PCS
3	SHORT BOLT (M6 x 35mm - RBW)		8PCS
4	LOCK WASHER (1/4" - BLK)		20PCS
5	SMALL FLAT WASHER (M6 x 13mm - RBW)		6PCS
6	BIG FLAT WASHER (1/4" - RBW)		14PCS
7	LEVELER (M6 x 14.8mm)		6PCS

ITEM: 193930NAT

ASSEMBLY INSTRUCTIONS



STEP 1

Unscrew all hardware Short Bolt, Lock Washer & Big Flat Washer.
Keep the hardware to be use in **STEP 5**.

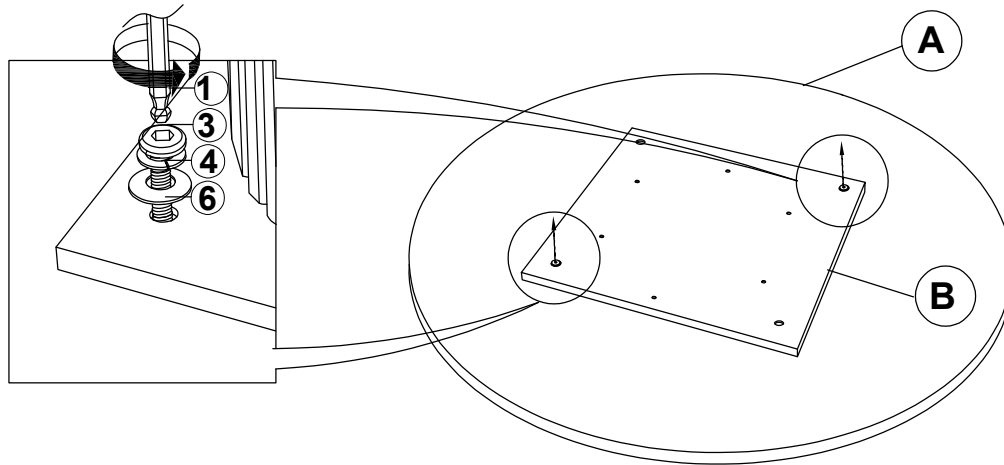

STEP 2

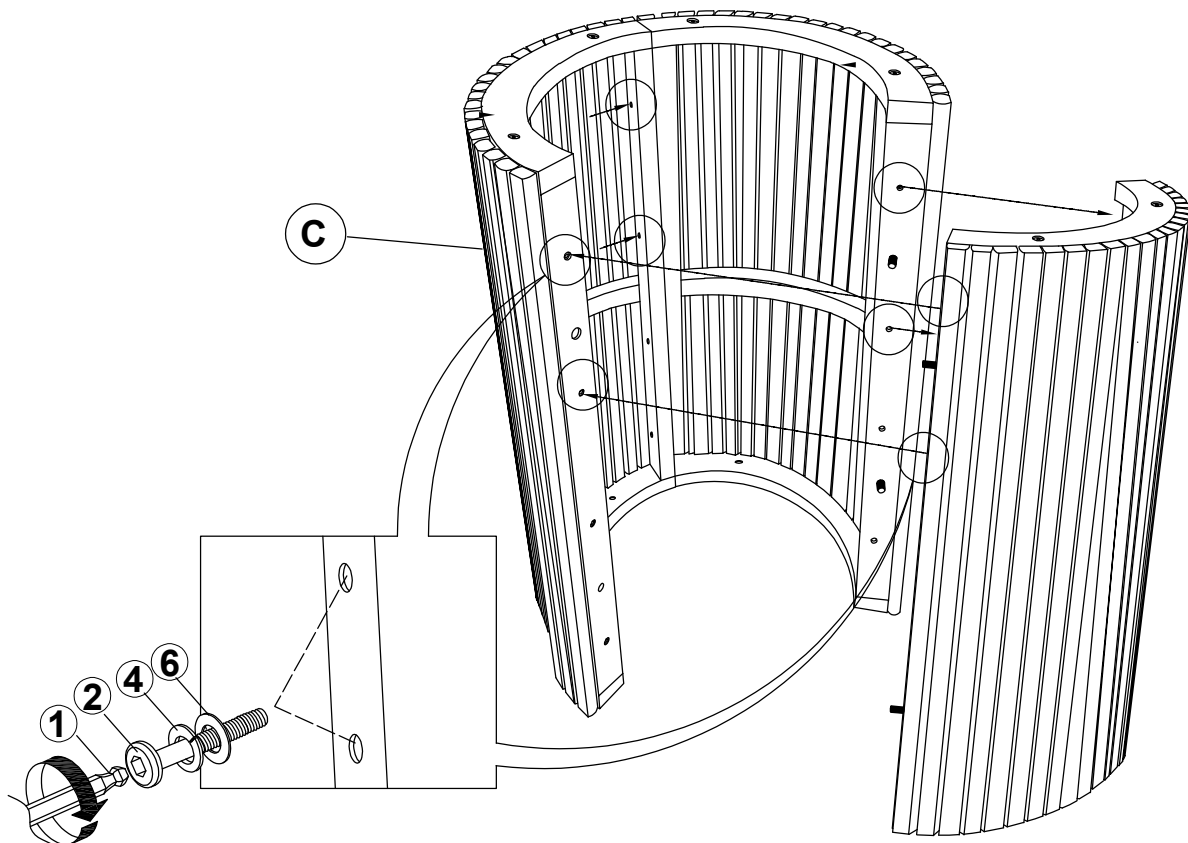

ITEM: 193930NAT

ASSEMBLY INSTRUCTIONS



STEP 3

Attention! Carefully turn the table base assembly to the other side before proceeding with the next step.

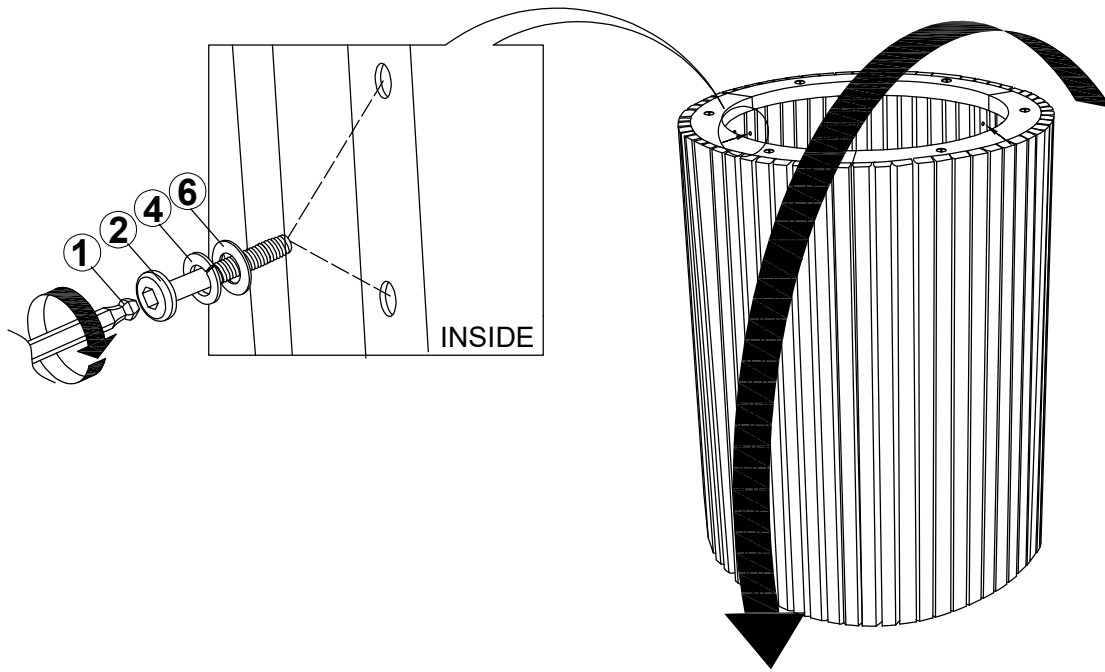

STEP 4

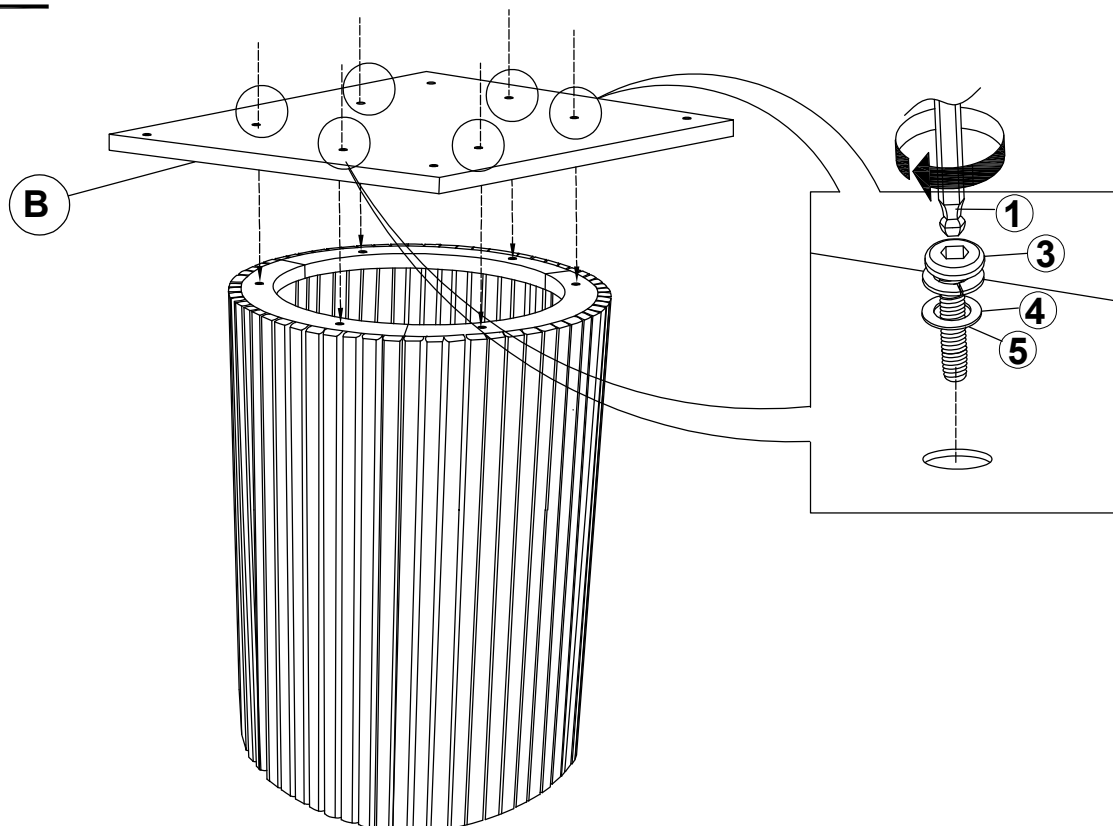

ITEM: **193930NAT**
ASSEMBLY INSTRUCTIONS



STEP 5

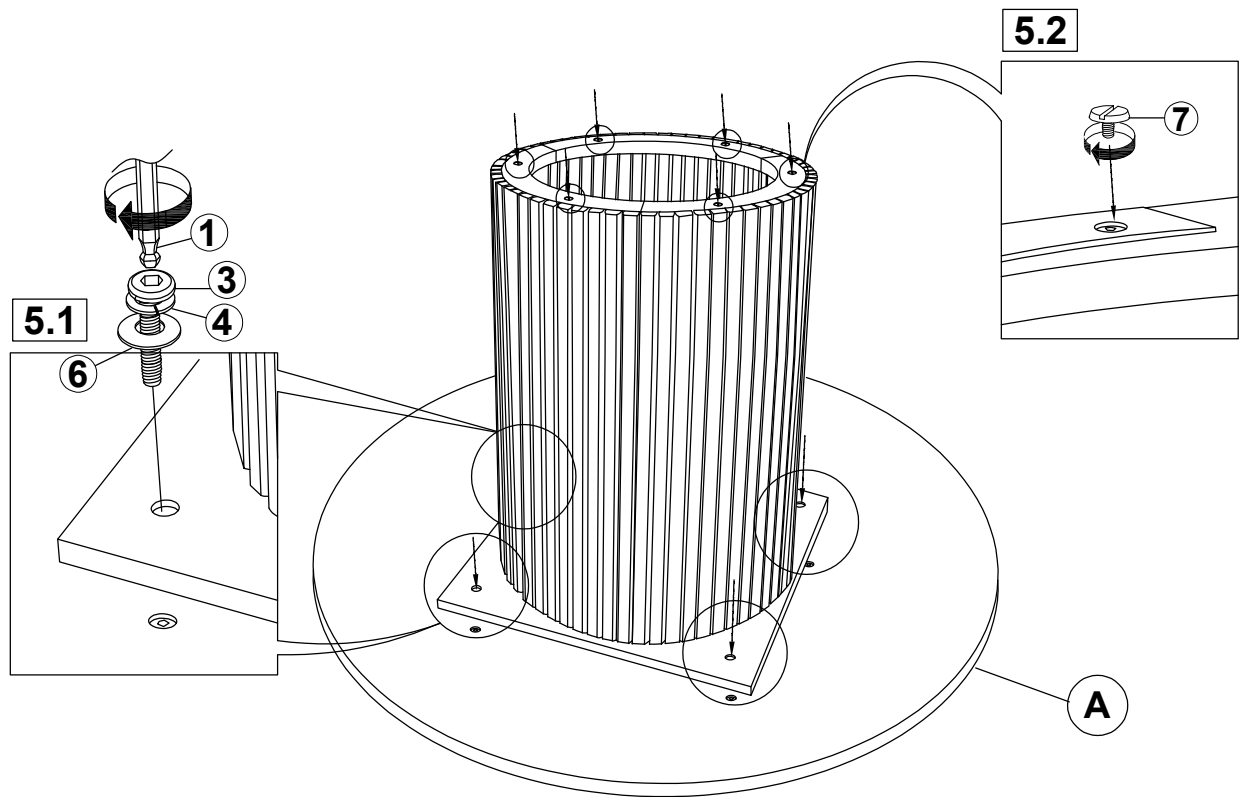

STEP 6
COMPLETE

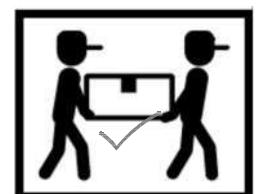
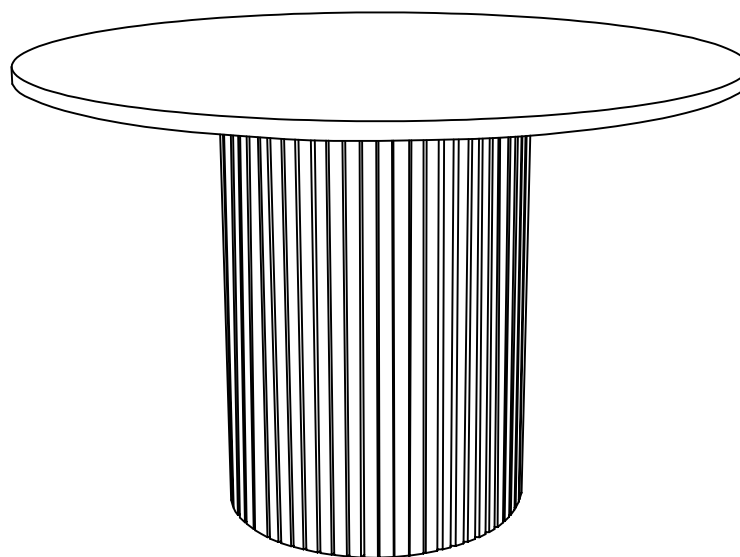

ITEM: **193930NAT**

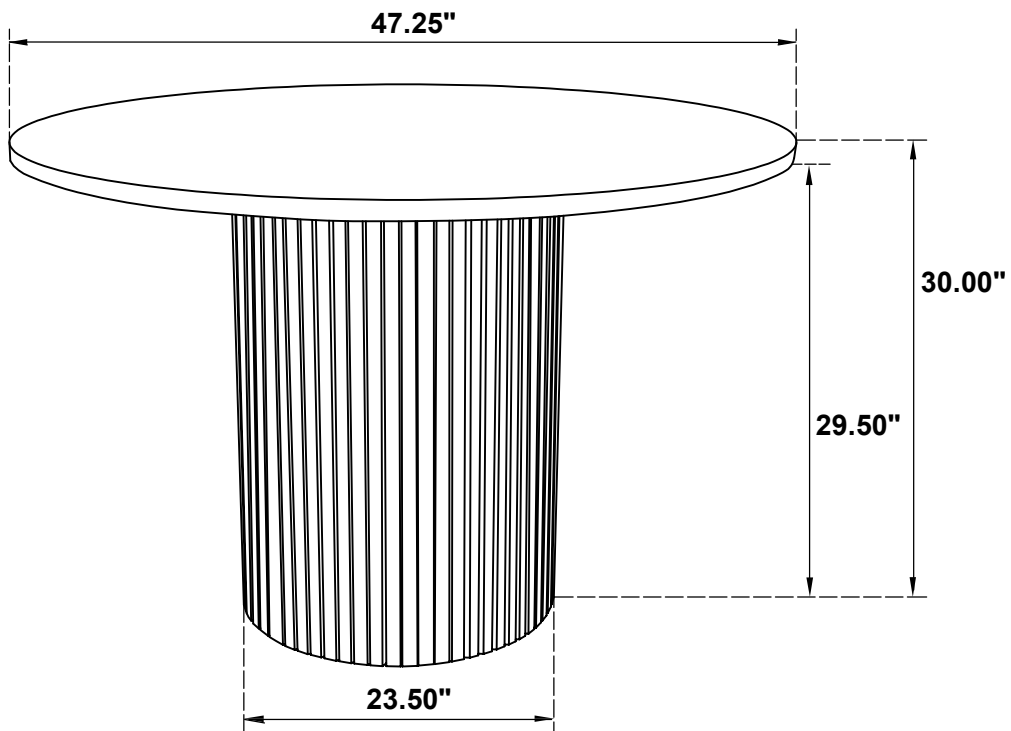

Note: Dimension tolerance $\pm 5\%$

ASSEMBLY INSTRUCTIONS
COASTER FINE FURNITURE



Fine Furniture for every stage of life

193942NAT
Side Chair

ITEM: 193942NAT



ASSEMBLY INSTRUCTIONS

ASSEMBLY TIPS:

1. Remove hardware from box and sort by size.
2. Please check to see that all hardware and parts are present prior to start of assembly.
3. Please follow attached instructions in the same sequence as numbered to assure fast & easy assembly.



WARNING!



1. Don't attempt to repair or modify parts that are broken or defective. Please contact the store immediately.
2. This product is for home use only and not intended for commercial establishments.





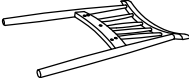
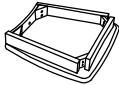

ASSEMBLY TIME

15 MINUTES

PARTS IDENTIFICATION

A	BACK FRAME		1PC
B	SEAT CUSHION WITH FRAME		1PC
C	LEFT FRONT LEG (WITH "C" LABEL)		1PC
D	RIGHT FRONT LEG (WITH "D" LABEL)		1PC

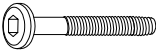
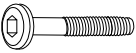
HARDWARE IDENTIFICATION

1	ALLEN WRENCH (M4 x 100mm - BLK)		1PC
2	LONG BOLT (M6 x 80mm - RBW)		4PCS
3	MEDIUM BOLT (M6 x 60mm - RBW)		4PCS
4	SHORT BOLT (M6 x 40mm - RBW)		1PC
5	LOCK WASHER (1/4" - BLK)		9PCS
6	FLAT WASHER (1/4" - RBW)		9PCS

NOTE :

Quantities shown are for one chair.

ITEM: 193942NAT

ASSEMBLY INSTRUCTIONS



STEP 1

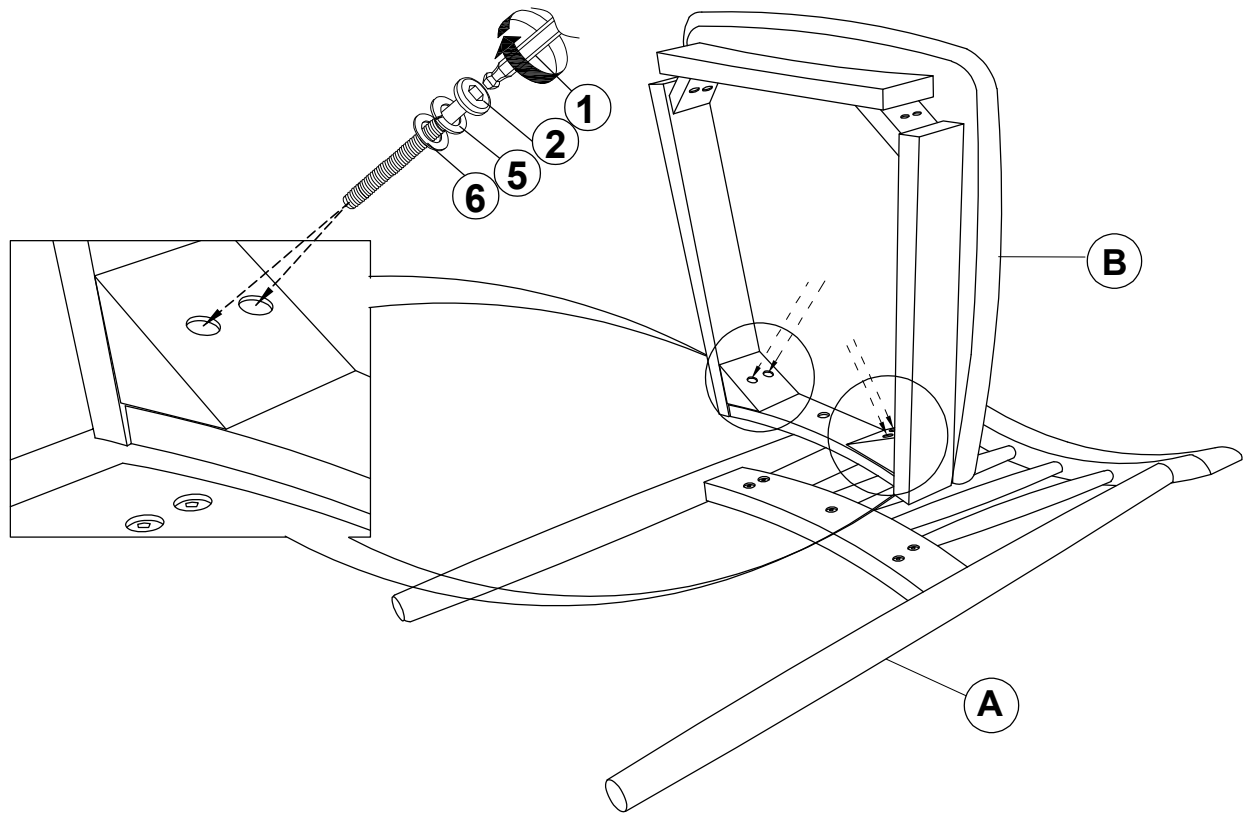

STEP 2

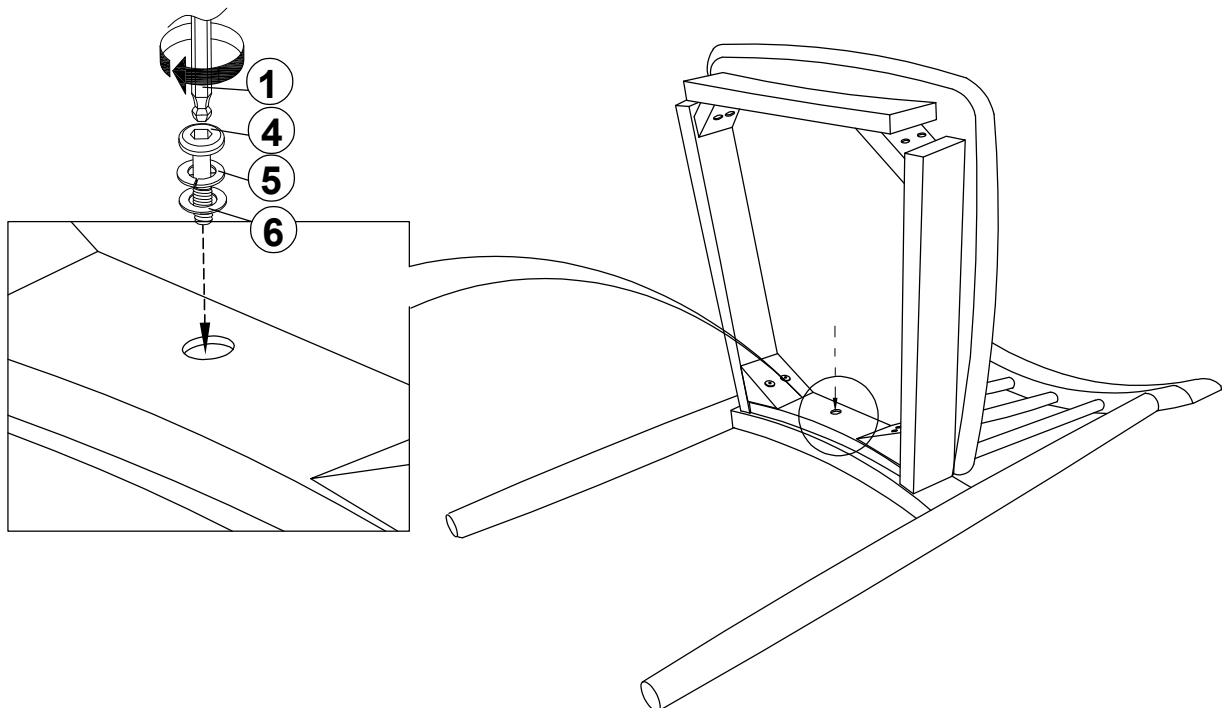

ITEM: **193942NAT**
ASSEMBLY INSTRUCTIONS
STEP 3

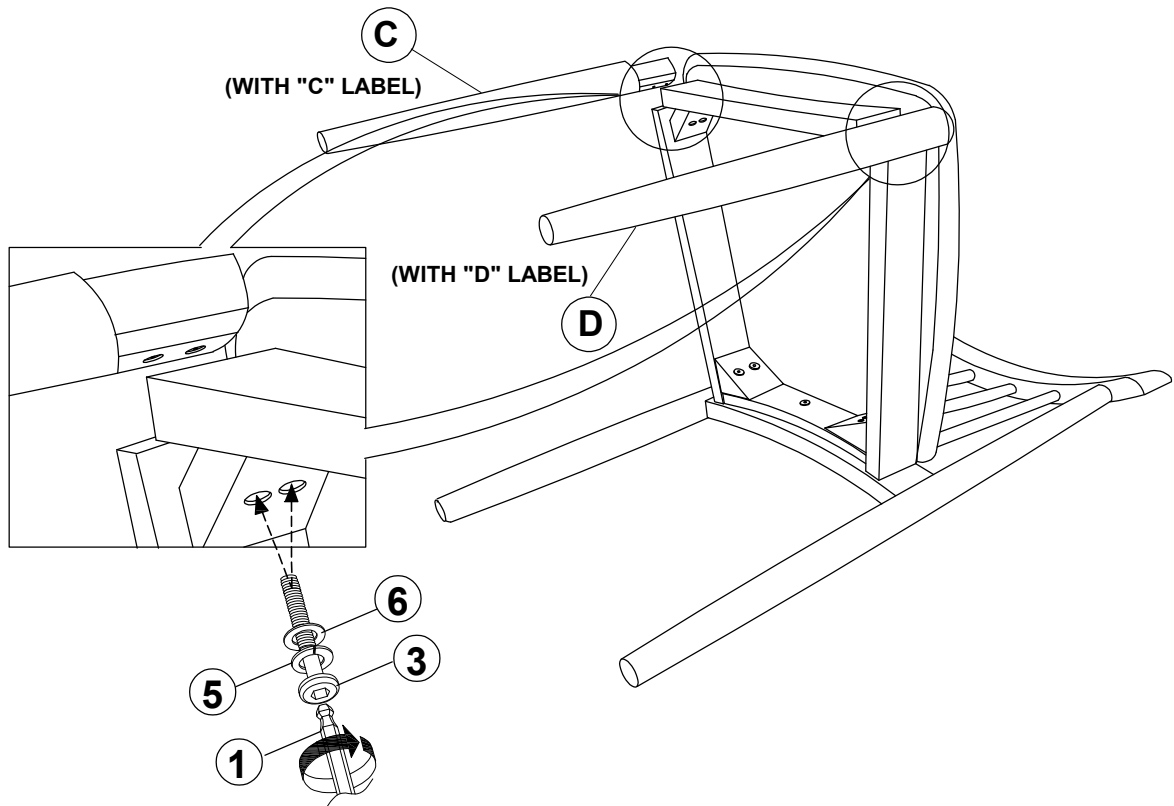

STEP 4
COMPLETE

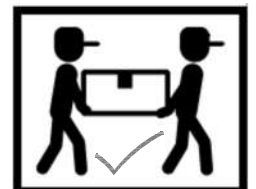
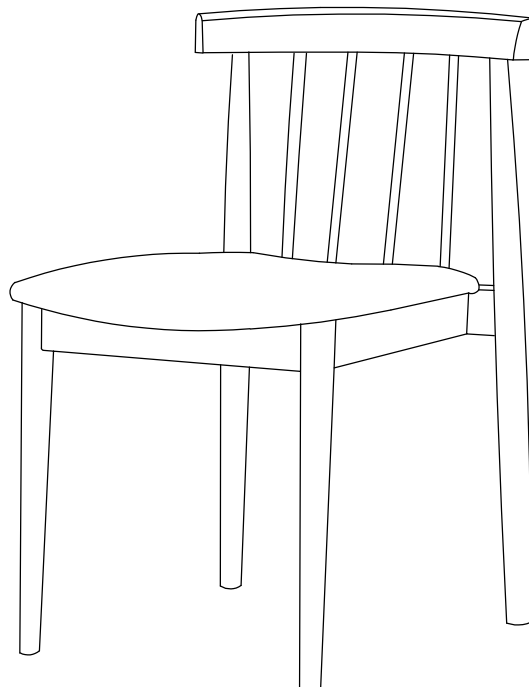

ITEM: **193942NAT**

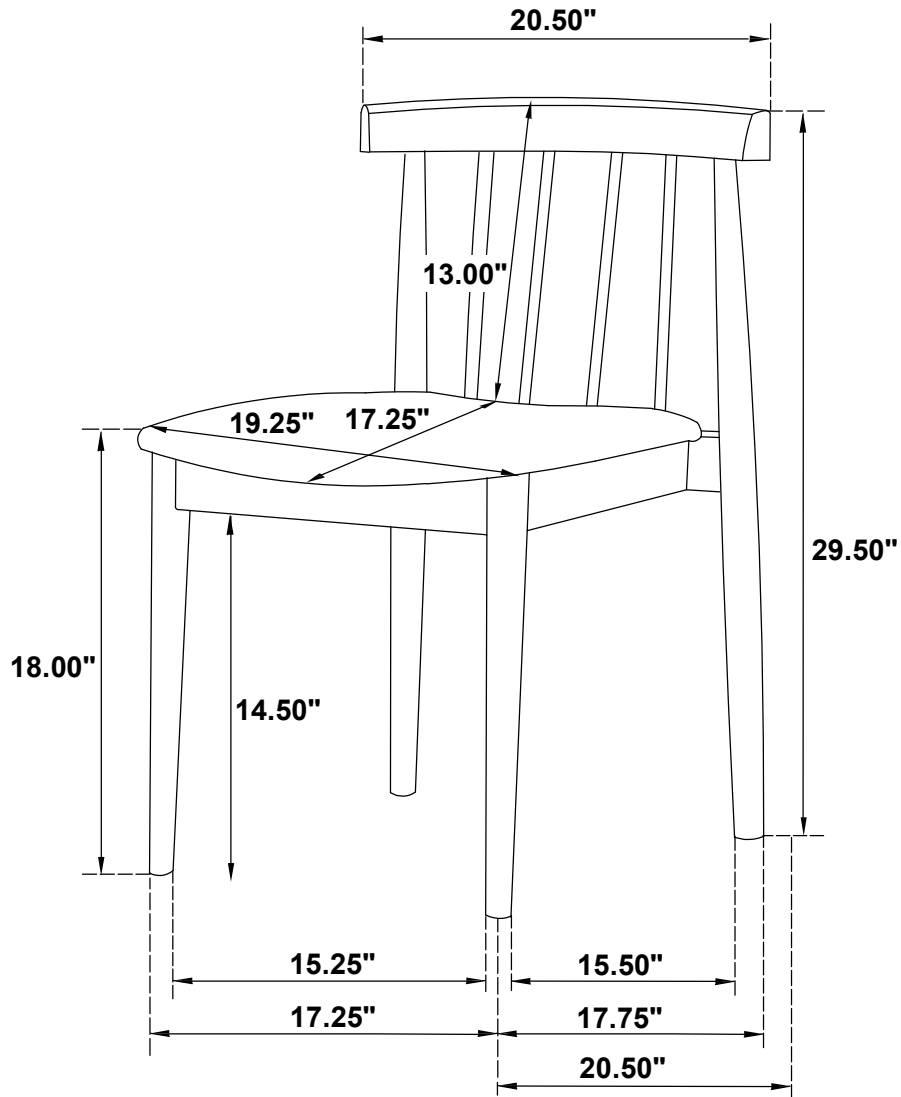

Note: Dimension tolerance $\pm 5\%$