

ASSEMBLY INSTRUCTIONS
COASTER FINE FURNITURE



Fine Furniture for every stage of life

193940BLK
Dining Table

ITEM: 193940BLK

ASSEMBLY INSTRUCTIONS



ASSEMBLY TIPS:

1. Remove hardware from box and sort by size.
2. Please check to see that all hardware and parts are present prior to start of assembly.
3. Please follow attached instructions in the same sequence as numbered to assure fast & easy assembly.



WARNING!

1. Don't attempt to repair or modify parts that are broken or defective. Please contact the store immediately.
2. This product is for home use only and not intended for commercial establishments.



ASSEMBLY TIME

15 MINUTES

PARTS IDENTIFICATION

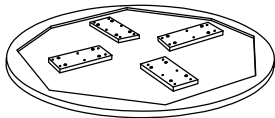
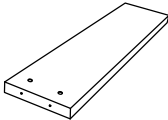
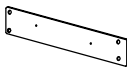
A	TOP		1PC
B	LEG		4PCS
C	MOUNTING BAR		4PCS

HARDWARE IDENTIFICATION

1	LONG ALLEN WRENCH (M5 x 95mm - BLK)		1PC
2	SHORT ALLEN WRENCH (M4 x 63mm - BLK)		1PC
3	HEX BOLT (M8 x 60mm - ZB)		8PCS
4	BOLT (M6 x 30mm - RBW)		16PCS
5	LOCK WASHER (1/4" - BLK)		16PCS
6	BARREL NUT (M8 x 12 x 18mm - ZB)		8PCS
7	WOOD PLUG (Ø14.5 x 9mm)		8PCS
8	LEVELER (M6 x 14.8mm)		4PCS

ITEM: 193940BLK

ASSEMBLY INSTRUCTIONS



STEP 1

Attention! Align the correction position for mounting bar before assembly

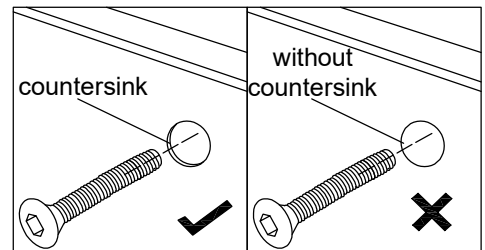
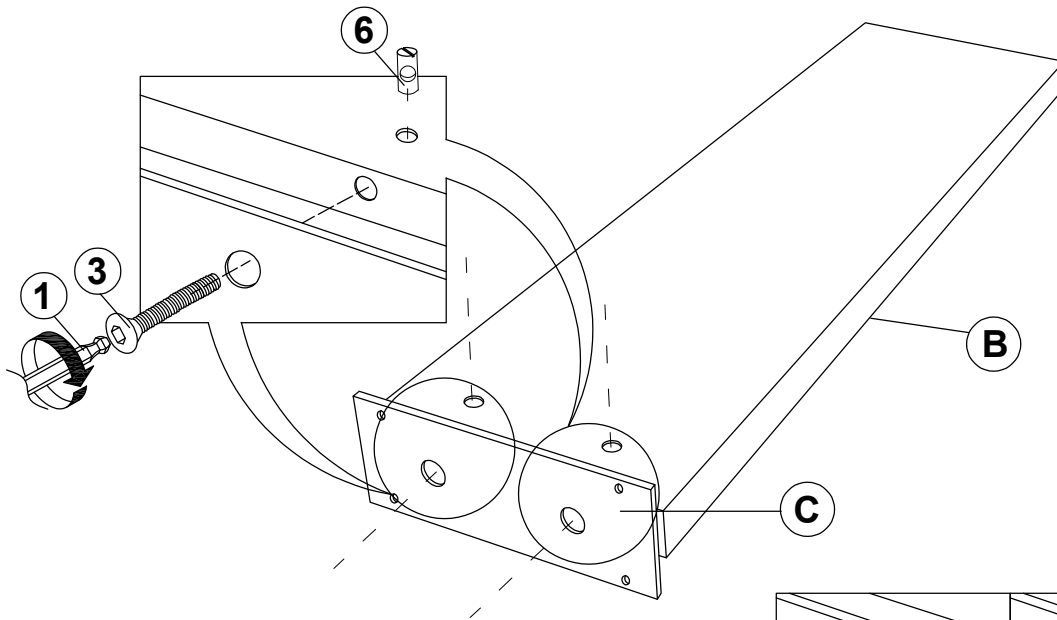

STEP 2

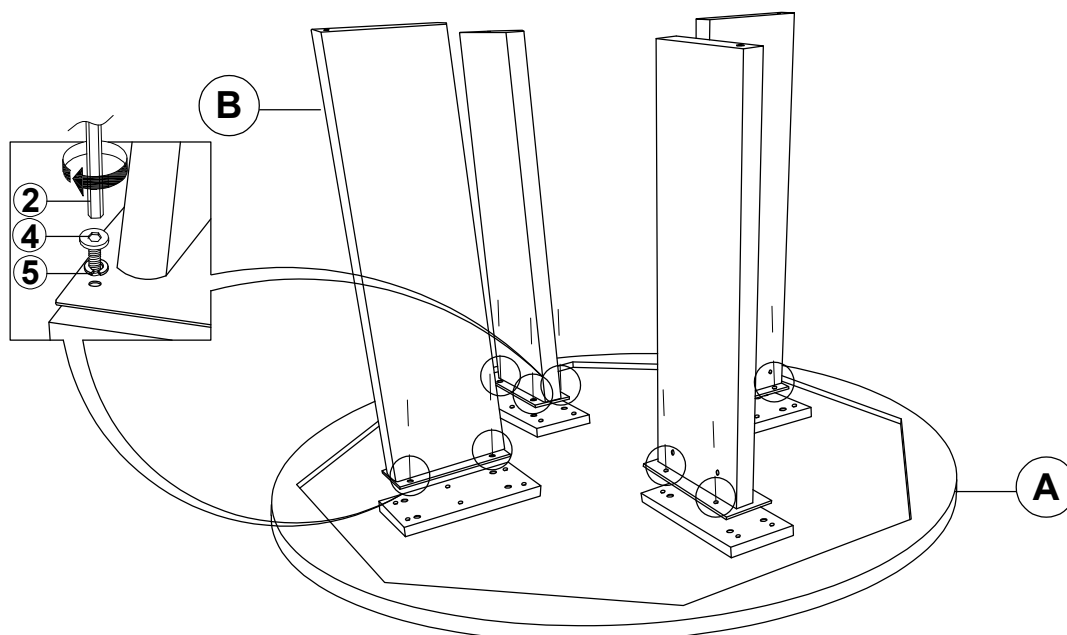

ITEM: **193940BLK**
ASSEMBLY INSTRUCTIONS



STEP 3

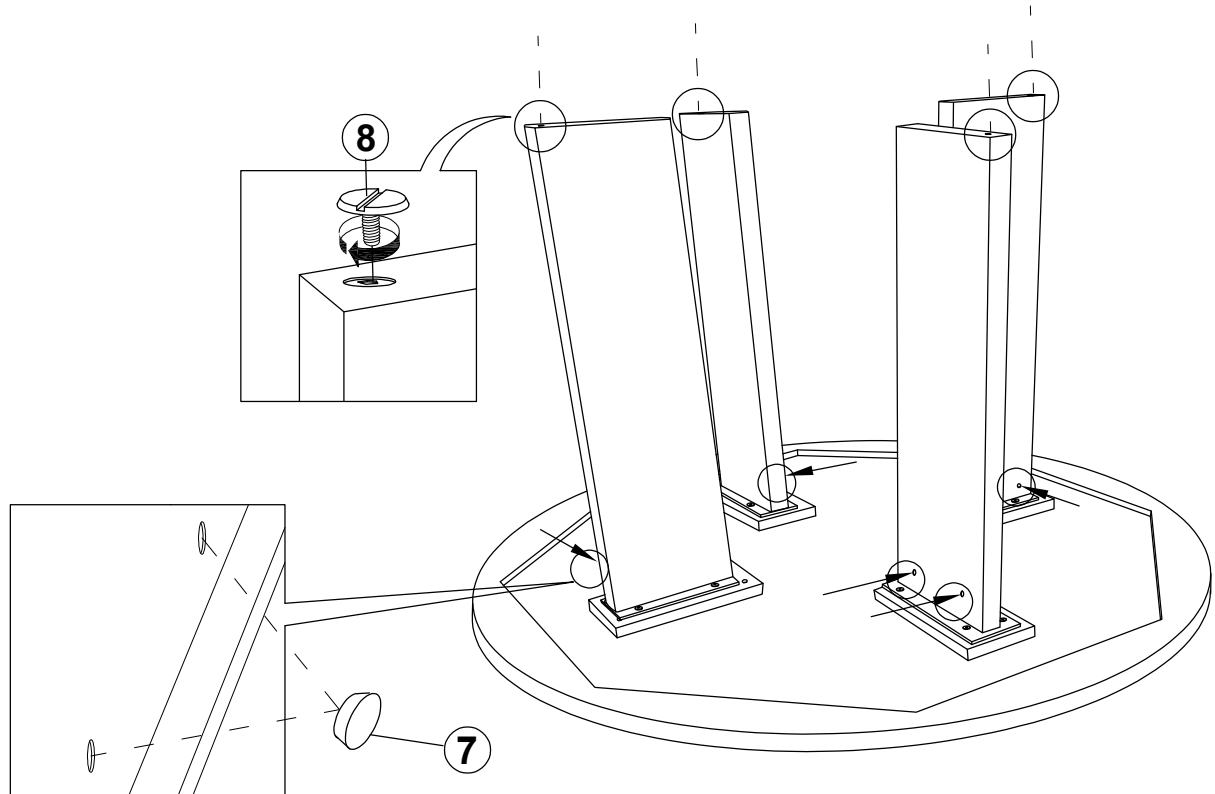

STEP 4
COMPLETE

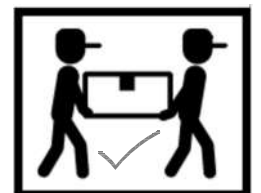
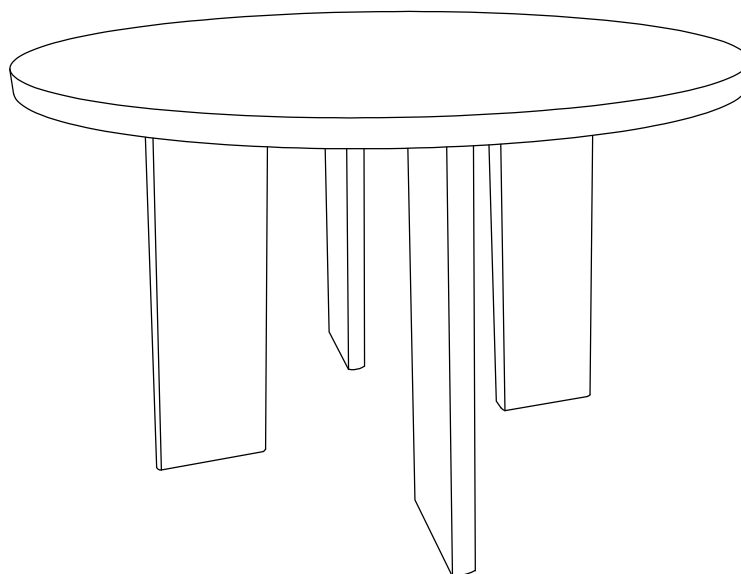

ITEM: **193940BLK**

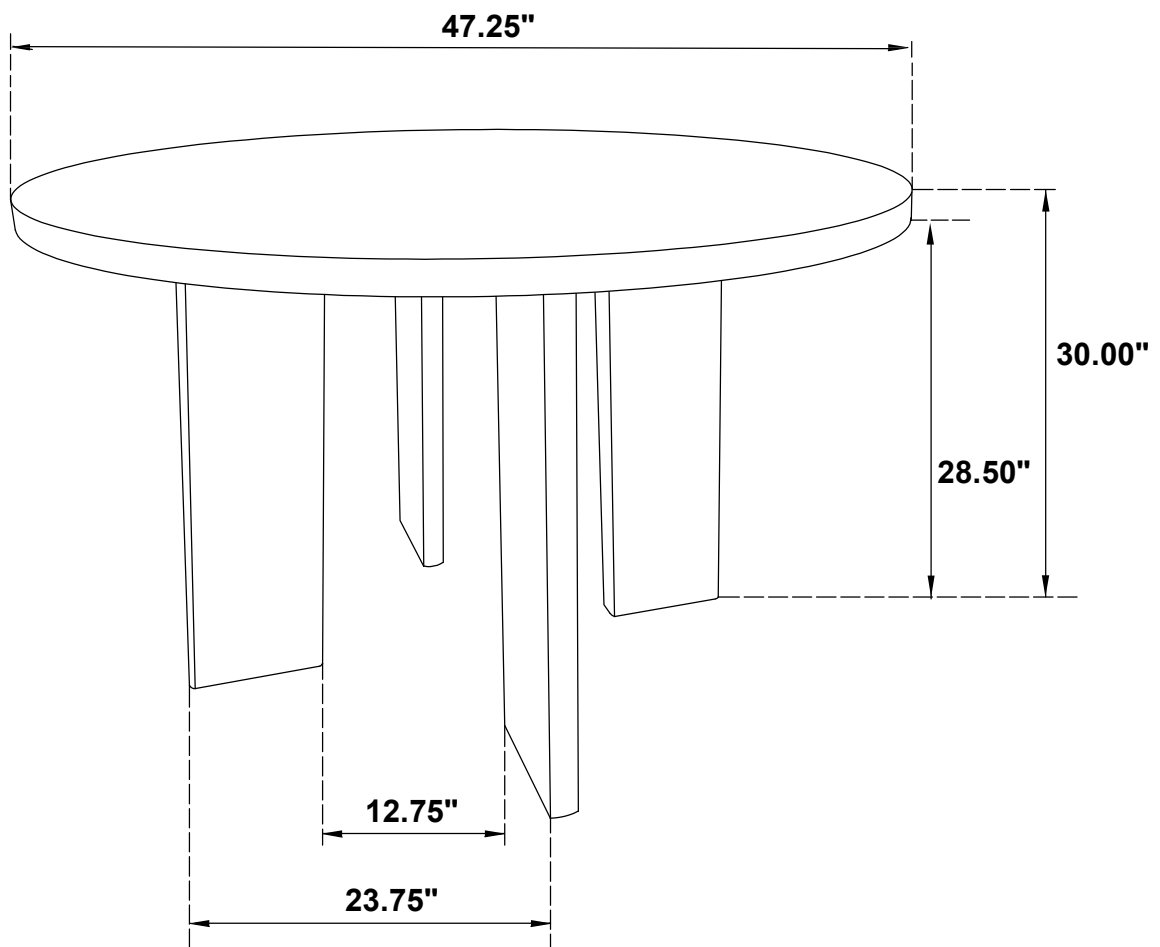

Note: Dimension tolerance $\pm 5\%$

ASSEMBLY INSTRUCTIONS
COASTER FINE FURNITURE



Fine Furniture for every stage of life

107202BLK
Side Chair

ITEM: 107202BLK

ASSEMBLY INSTRUCTIONS



ASSEMBLY TIPS:

1. Remove hardware from box and sort by size.
2. Please check to see that all hardware and parts are present prior to start of assembly.
3. Please follow attached instructions in the same sequence as numbered to assure fast & easy assembly.



WARNING!

1. Don't attempt to repair or modify parts that are broken or defective. Please contact the store immediately.
2. This product is for home use only and not intended for commercial establishments.



ASSEMBLY TIME

15 MINUTES

PARTS IDENTIFICATION

A	SEAT AND BACK		1PC
B	LEFT LEG FRAME		1PC
C	RIGHT LEG FRAME		1PC
D	STRETCHER		1PC

HARDWARE IDENTIFICATION

1	BOLT (5/16" x 35mm - BLK)		4PCS
2	LOCK WASHER (5/16" x 14mm - BLK)		4PCS
3	FLAT WASHER (5/16" x 19mm - BLK)		4PCS
4	ALLEN WRENCH (4mm x 64mm - BLK)		1PC
5	PAN HEAD SCREW (Ø4 x 30mm - BLK)		2PCS
6	WOODEN LOCK (Ø10 x 25mm - WOOD)		2PCS

NOTE:

Quantities shown are for one chair.

Phillips head screw driver is required in the assembly process; however, manufacturer does not provide this item.

ITEM: **107202BLK**
ASSEMBLY INSTRUCTIONS

STEP 1

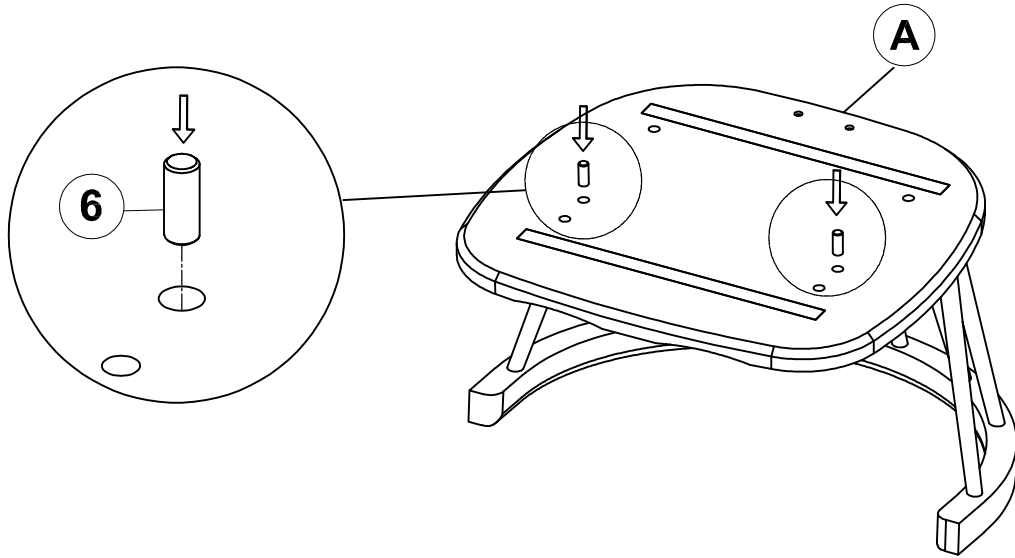

STEP 2

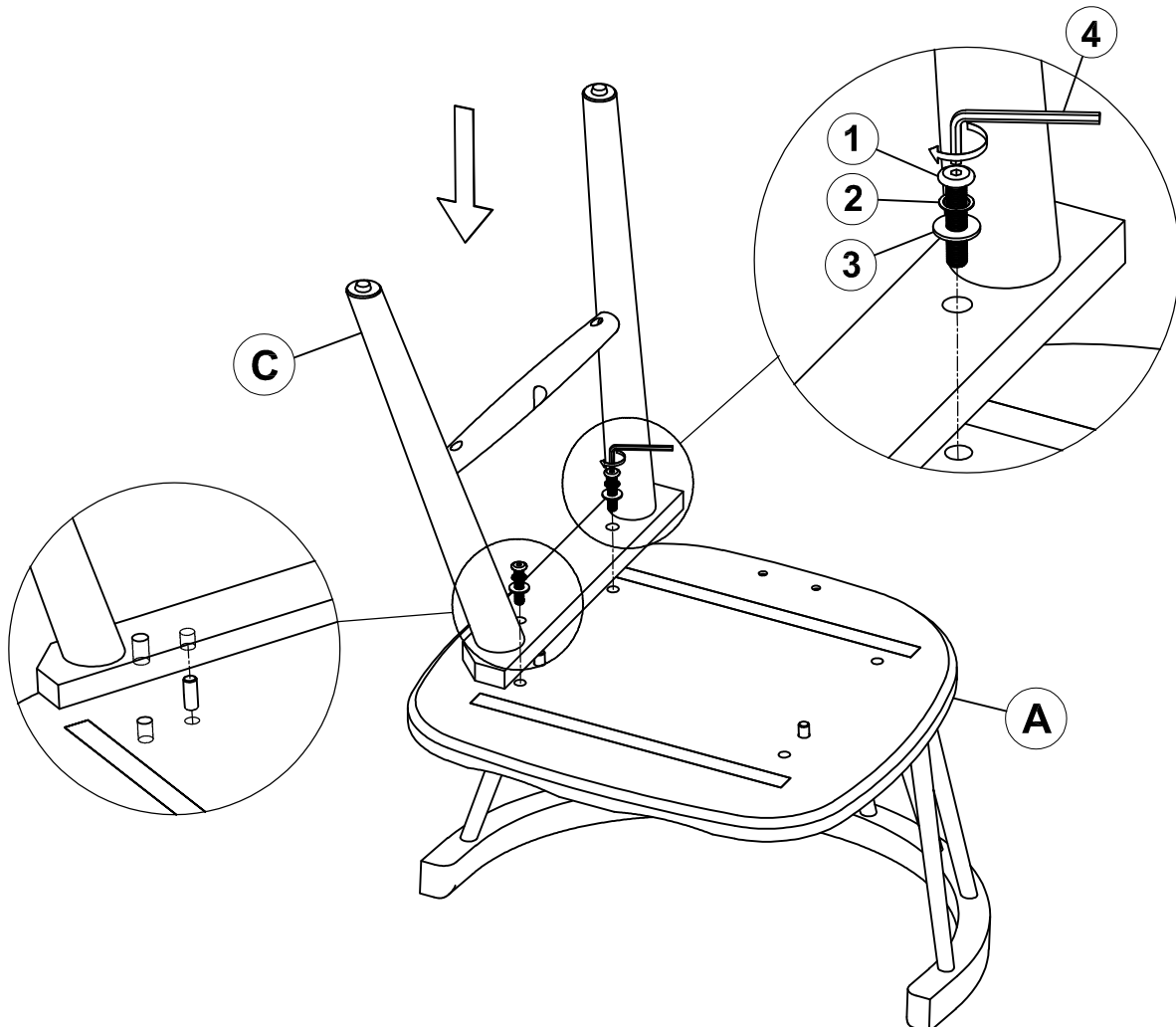

ITEM: **107202BLK**
ASSEMBLY INSTRUCTIONS

STEP 3

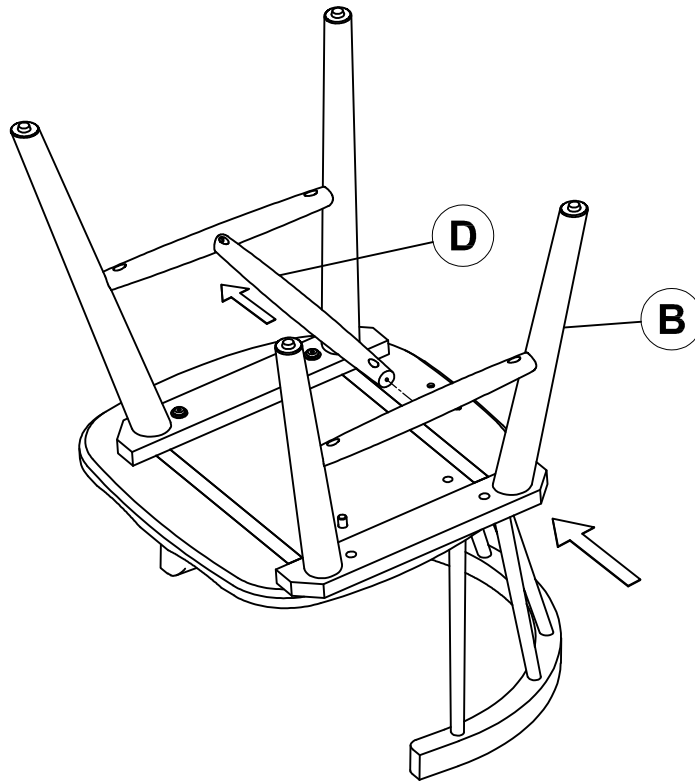

STEP 4

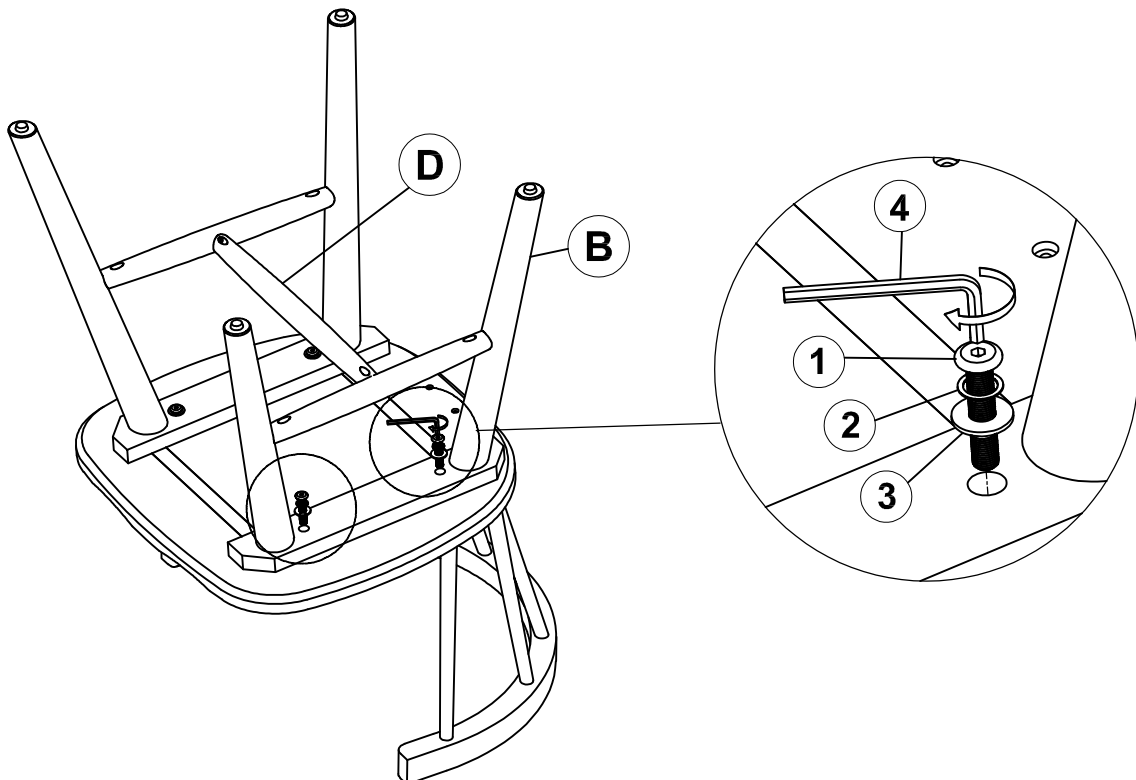

ITEM: **107202BLK**
ASSEMBLY INSTRUCTIONS



STEP 5

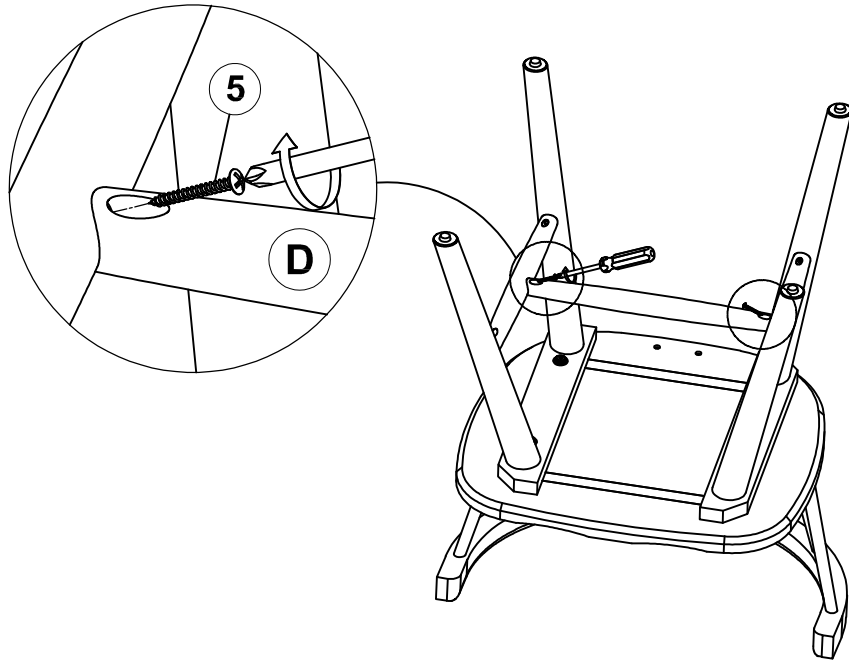

STEP 6
COMPLETE

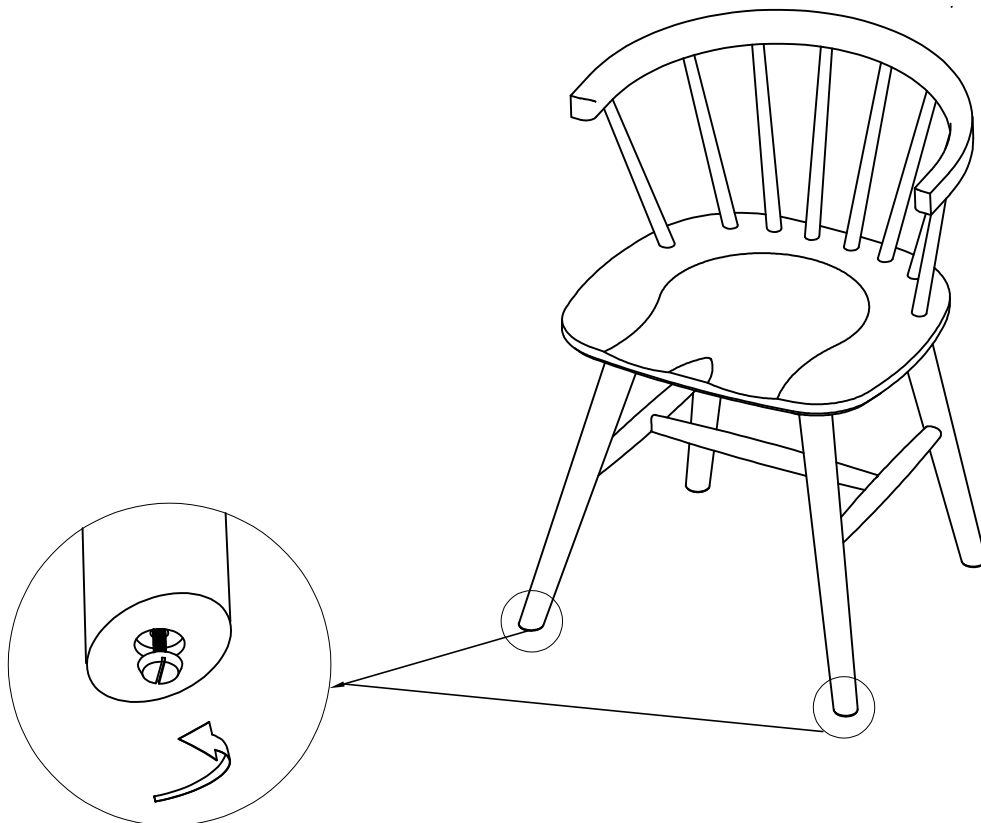

ITEM: **107202BLK**

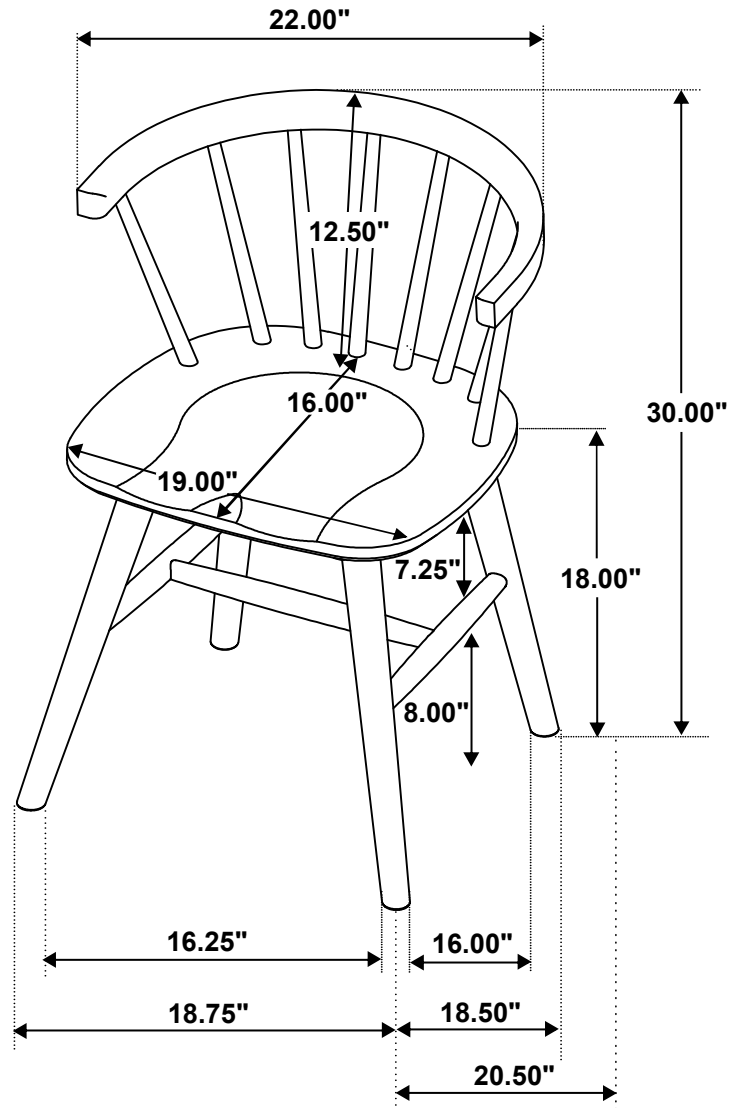

Note: Dimension tolerance $\pm 5\%$