

*ASSEMBLY INSTRUCTIONS*  
*COASTER FINE FURNITURE*



*Fine Furniture for every stage of life*

**193940BLK**  
***Dining Table***

# ITEM: 193940BLK

## ASSEMBLY INSTRUCTIONS



### ASSEMBLY TIPS:

1. Remove hardware from box and sort by size.
2. Please check to see that all hardware and parts are present prior to start of assembly.
3. Please follow attached instructions in the same sequence as numbered to assure fast & easy assembly.



### WARNING!

1. Don't attempt to repair or modify parts that are broken or defective. Please contact the store immediately.
2. This product is for home use only and not intended for commercial establishments.







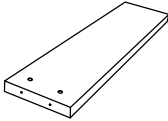
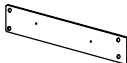

**ASSEMBLY TIME**

**15 MINUTES**

## PARTS IDENTIFICATION

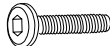
<b>A</b>	<b>TOP</b>		<b>1PC</b>
<b>B</b>	<b>LEG</b>		<b>4PCS</b>
<b>C</b>	<b>MOUNTING BAR</b>		<b>4PCS</b>

## HARDWARE IDENTIFICATION

<b>1</b>	<b>LONG ALLEN WRENCH</b> (M5 x 95mm - BLK)		<b>1PC</b>
<b>2</b>	<b>SHORT ALLEN WRENCH</b> (M4 x 63mm - BLK)		<b>1PC</b>
<b>3</b>	<b>HEX BOLT</b> (M8 x 60mm - ZB)		<b>8PCS</b>
<b>4</b>	<b>BOLT</b> (M6 x 30mm - RBW)		<b>16PCS</b>
<b>5</b>	<b>LOCK WASHER</b> (1/4" - BLK)		<b>16PCS</b>
<b>6</b>	<b>BARREL NUT</b> (M8 x 12 x 18mm - ZB)		<b>8PCS</b>
<b>7</b>	<b>WOOD PLUG</b> (Ø14.5 x 9mm)		<b>8PCS</b>
<b>8</b>	<b>LEVELER</b> (M6 x 14.8mm)		<b>4PCS</b>

# ITEM: 193940BLK

## ASSEMBLY INSTRUCTIONS



### STEP 1

Attention! Align the correction position for mounting bar before assembly

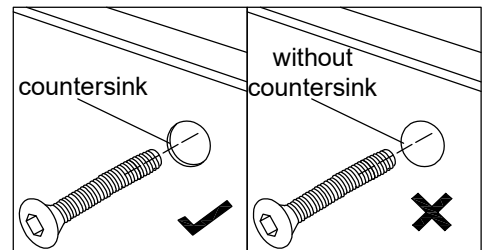
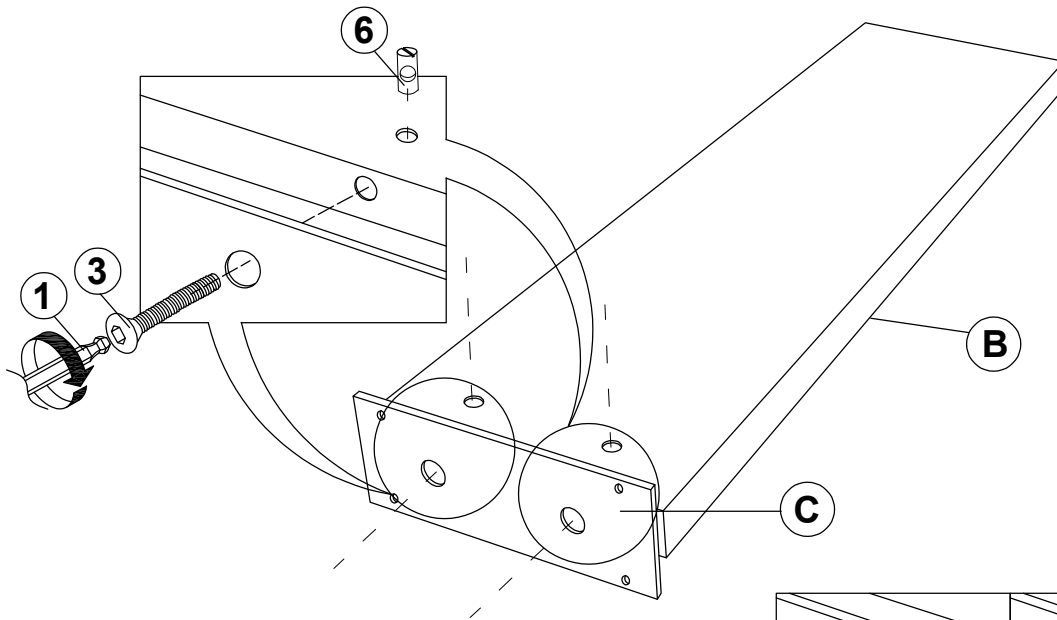

### STEP 2

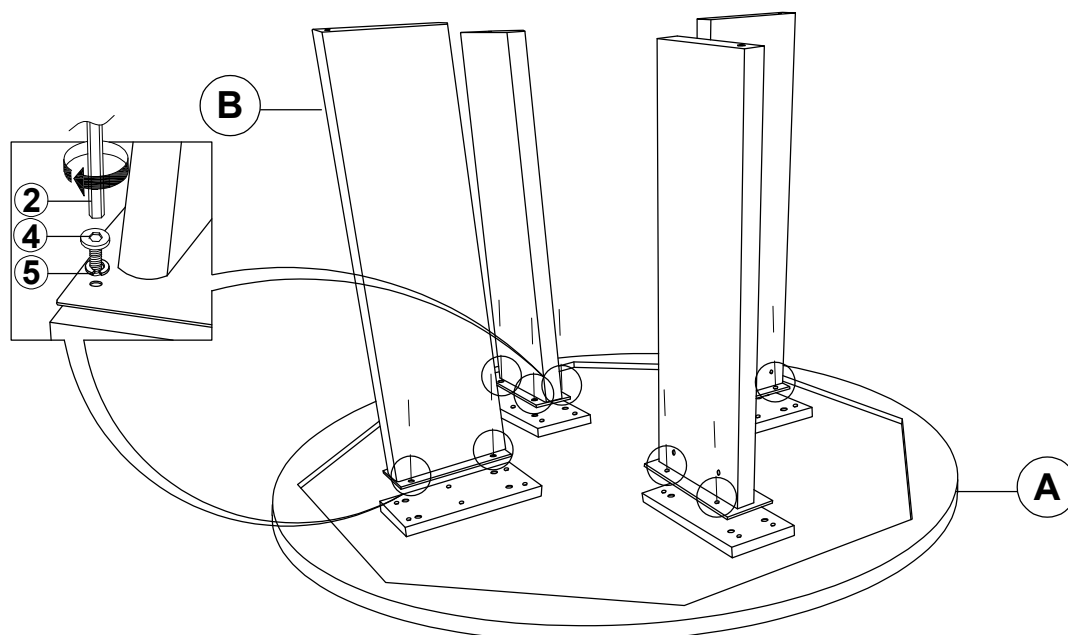

ITEM: **193940BLK**  
**ASSEMBLY INSTRUCTIONS**



**STEP 3**

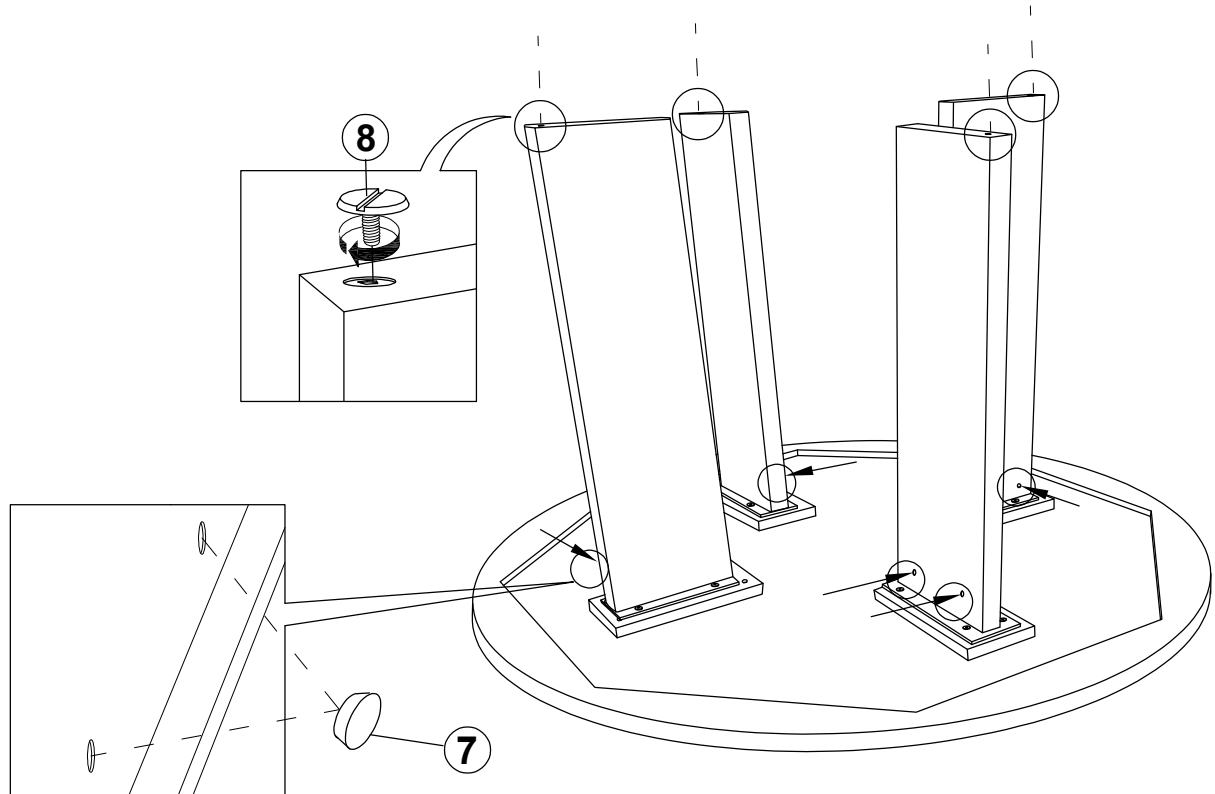

**STEP 4**  
**COMPLETE**

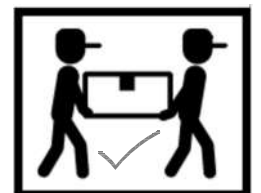
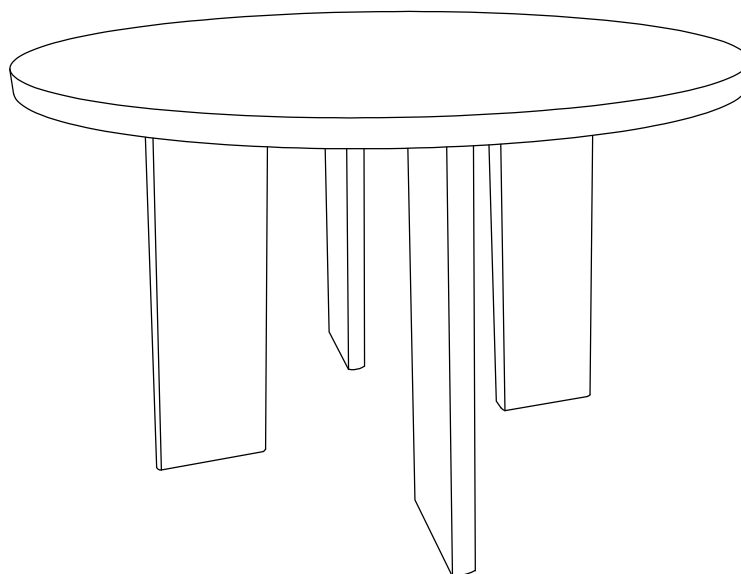

ITEM: **193940BLK**

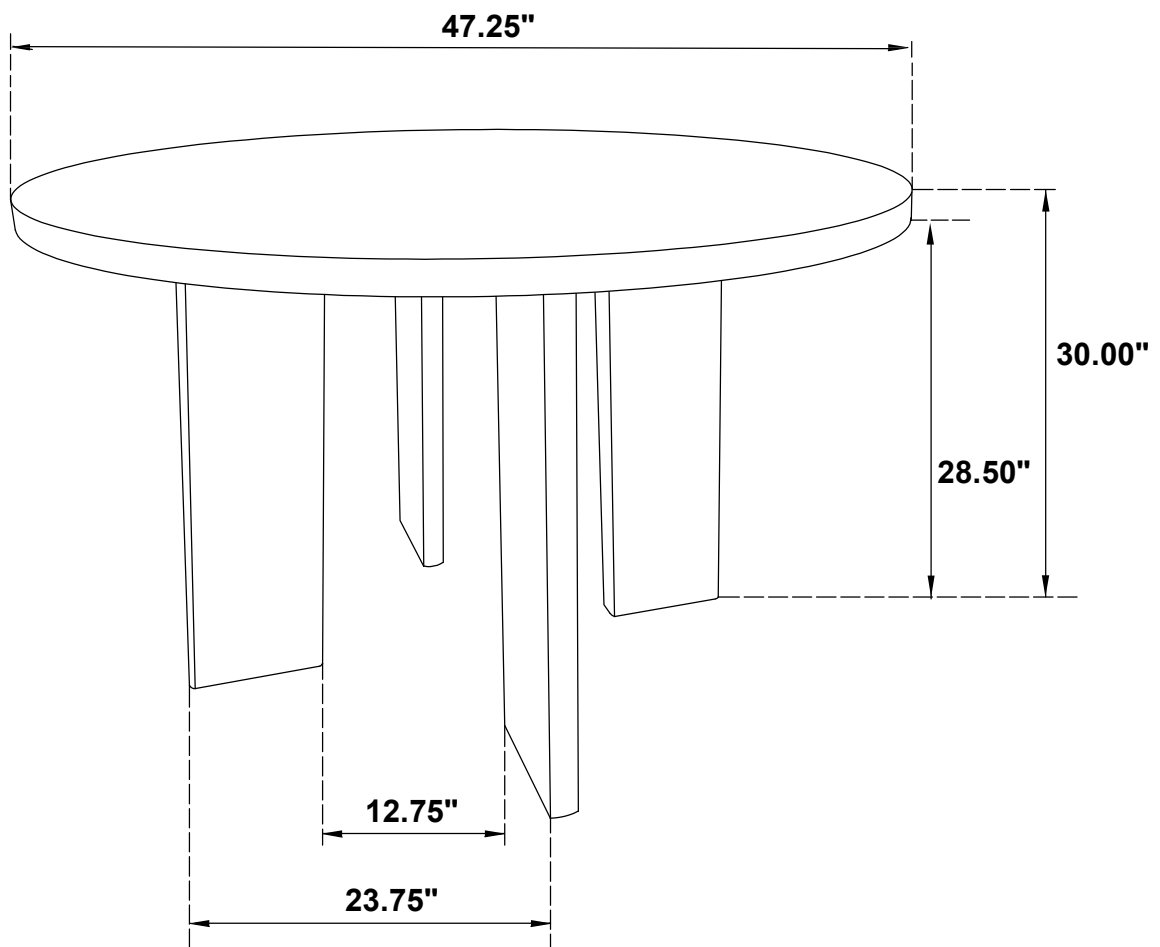

**Note: Dimension tolerance  $\pm 5\%$**



*ASSEMBLY INSTRUCTIONS*  
*COASTER FINE FURNITURE*



*Fine Furniture for every stage of life*

**122502BLK**  
***Side Chair***

# ITEM : 122502BLK

## ASSEMBLY INSTRUCTION



### ASSEMBLY TIPS :

1. Remove hardware from box and sort by size.
2. Please check to see that all hardware and parts are present prior to start of assembly.
3. Please follow attached instructions in the same sequence as numbered to assure fast & easy assembly.



### WARNING :

1. Don't attempt to repair or modify parts that are broken or defective. Please contact the store immediately
2. This product is for home use only and not intended for commercial establishments.



ASSEMBLY TIME

15 MINUTES

## PARTS IDENTIFICATION

A SEAT AND BACK

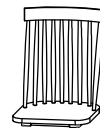

1PC

B LEG FRAME



2PCS

C STRETCHER



2PCS

## HARDWARE IDENTIFICATION

1 BOLT  
(Ø1/4" x 35mm - RBW)



4PCS

2 LOCK WASHER  
(Ø5/16" x 13mm - RBW)



4PCS

3 FLAT WASHER  
(Ø5/16" x 19mm - RBW)



4PCS

4 PAN HEAD SCREW  
(Ø4" x 28mm - RBW)

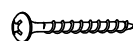

4PCS

5 ALLEN WRENCH  
(M4 x 59mm - RBW)

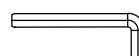

1PC

### NOTE:

Quantities shown are for one chair.

Phillips head screw driver is required in the assembly process. However, manufacturer does not provide this item.

# ITEM : 122502BLK

## ASSEMBLY INSTRUCTION



### STEP 1

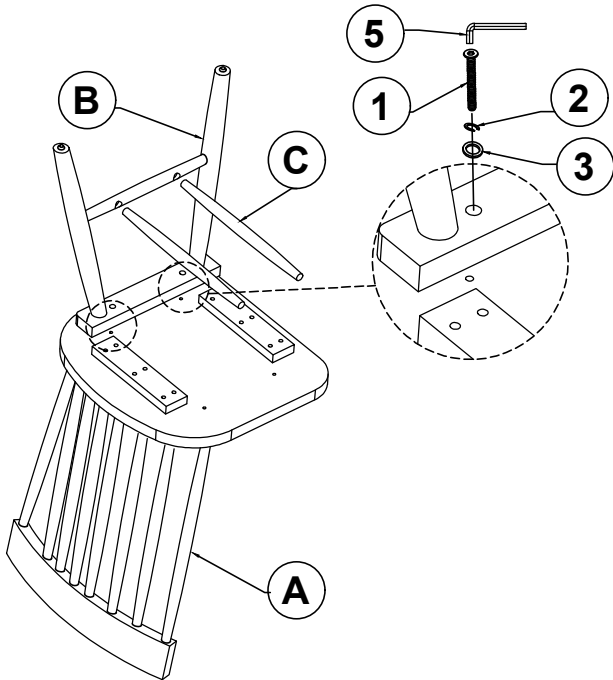

### STEP 2

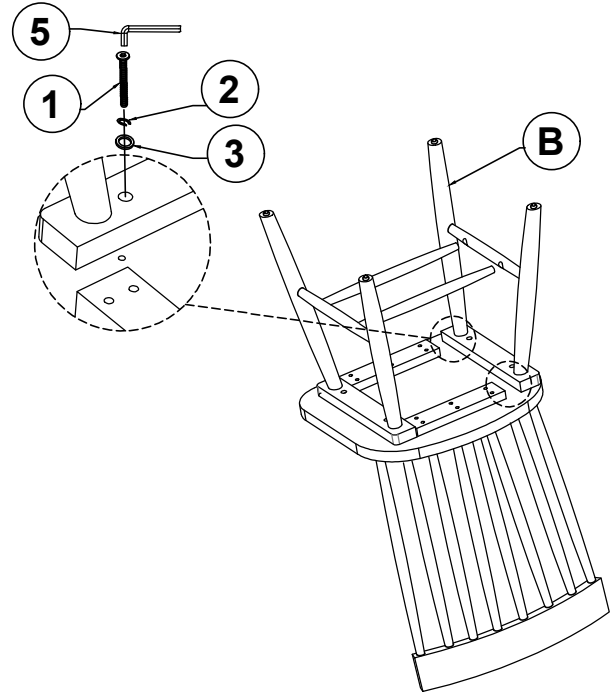

### STEP 3

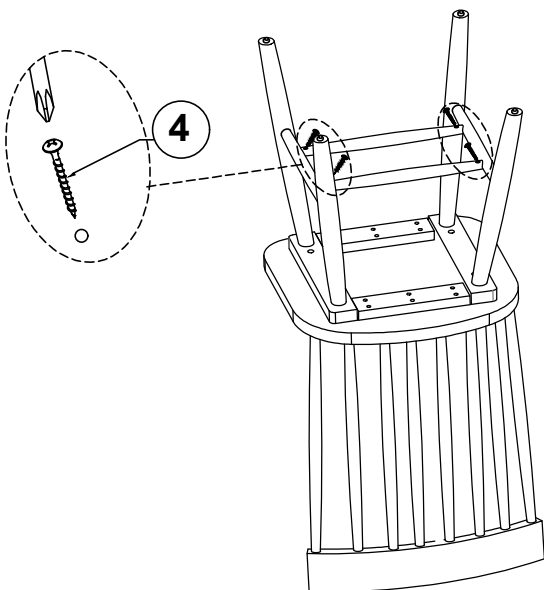

### STEP 4 **COMPLETE**

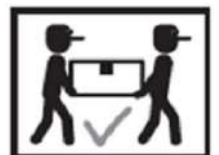
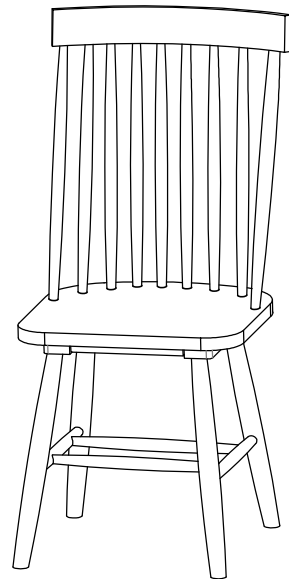

ITEM : **122502BLK**

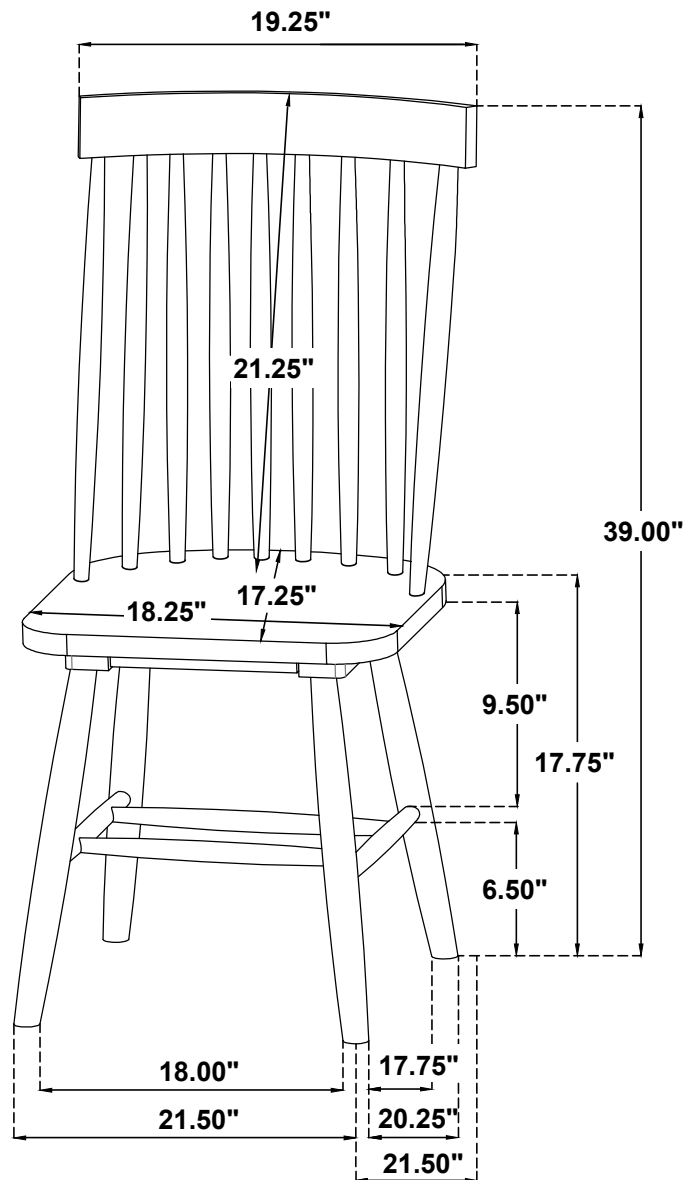

Note: Dimension tolerance  $\pm 5\%$