

ASSEMBLY INSTRUCTIONS
COASTER FINE FURNITURE



Fine Furniture for every stage of life

193942WAL
Side Chair

ITEM: 193942WAL

ASSEMBLY INSTRUCTIONS



ASSEMBLY TIPS:

1. Remove hardware from box and sort by size.
2. Please check to see that all hardware and parts are present prior to start of assembly.
3. Please follow attached instructions in the same sequence as numbered to assure fast & easy assembly.



WARNING!



1. Don't attempt to repair or modify parts that are broken or defective. Please contact the store immediately.
2. This product is for home use only and not intended for commercial establishments.





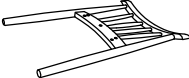
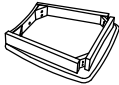

ASSEMBLY TIME

15 MINUTES

PARTS IDENTIFICATION

A	BACK FRAME		1PC
B	SEAT CUSHION WITH FRAME		1PC
C	LEFT FRONT LEG (WITH "C" LABEL)		1PC
D	RIGHT FRONT LEG (WITH "D" LABEL)		1PC

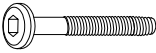
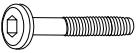
HARDWARE IDENTIFICATION

1	ALLEN WRENCH (M4 x 100mm - BLK)		1PC
2	LONG BOLT (M6 x 80mm - RBW)		4PCS
3	MEDIUM BOLT (M6 x 60mm - RBW)		4PCS
4	SHORT BOLT (M6 x 40mm - RBW)		1PC
5	LOCK WASHER (1/4" - BLK)		9PCS
6	FLAT WASHER (1/4" - RBW)		9PCS

NOTE :

Quantities shown are for one chair.

ITEM: 193942WAL

ASSEMBLY INSTRUCTIONS



STEP 1

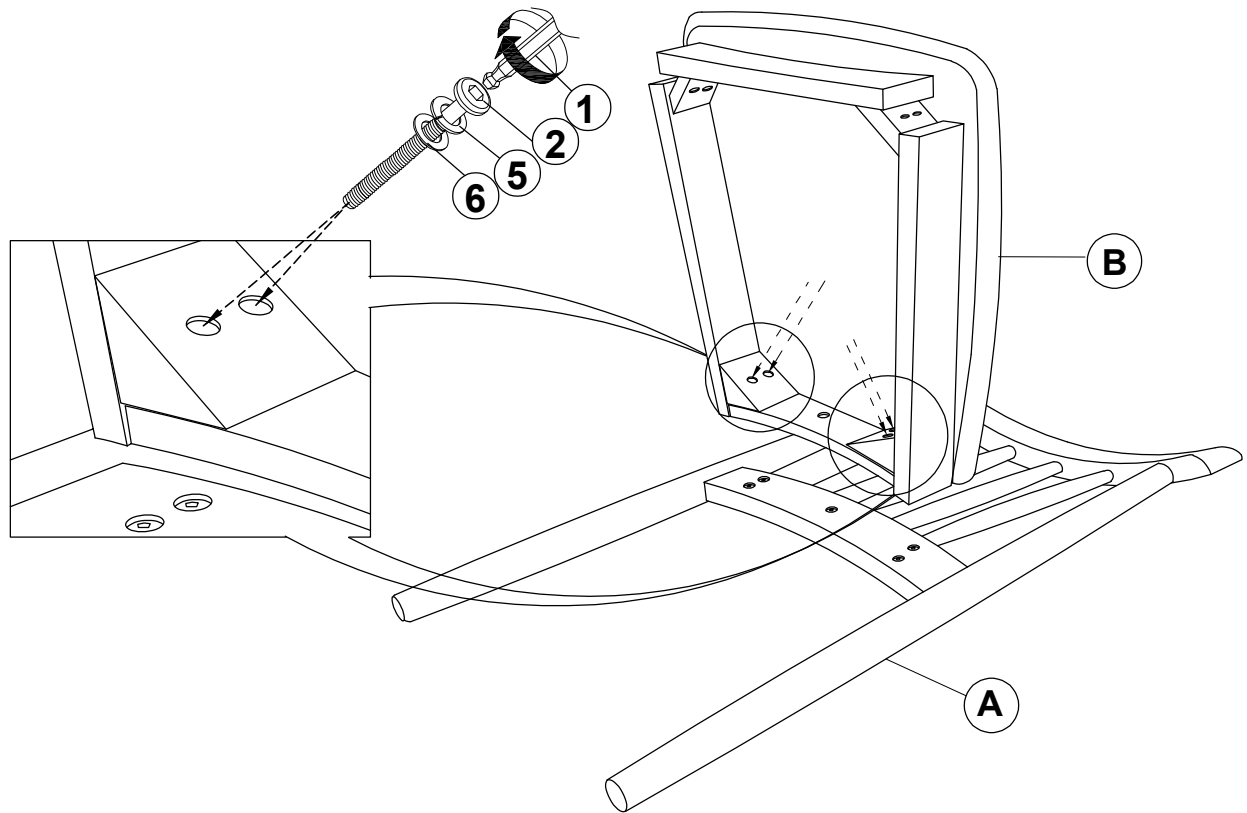

STEP 2

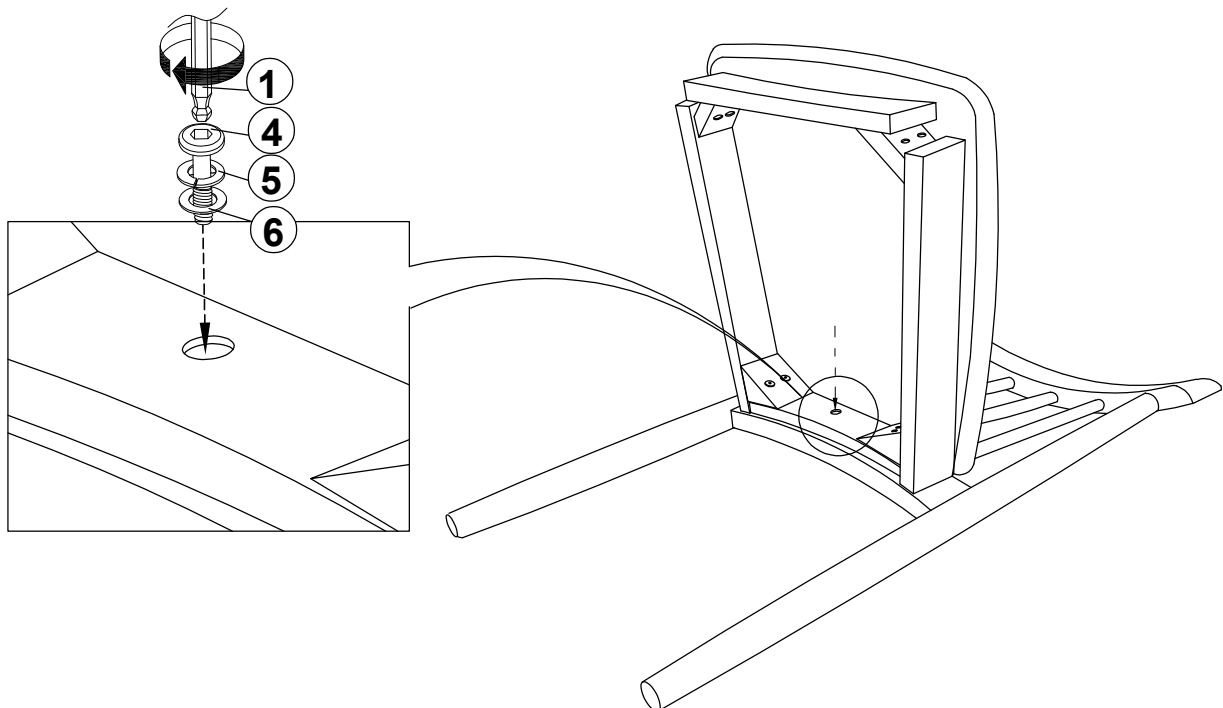

ITEM: **193942WAL**
ASSEMBLY INSTRUCTIONS
STEP 3

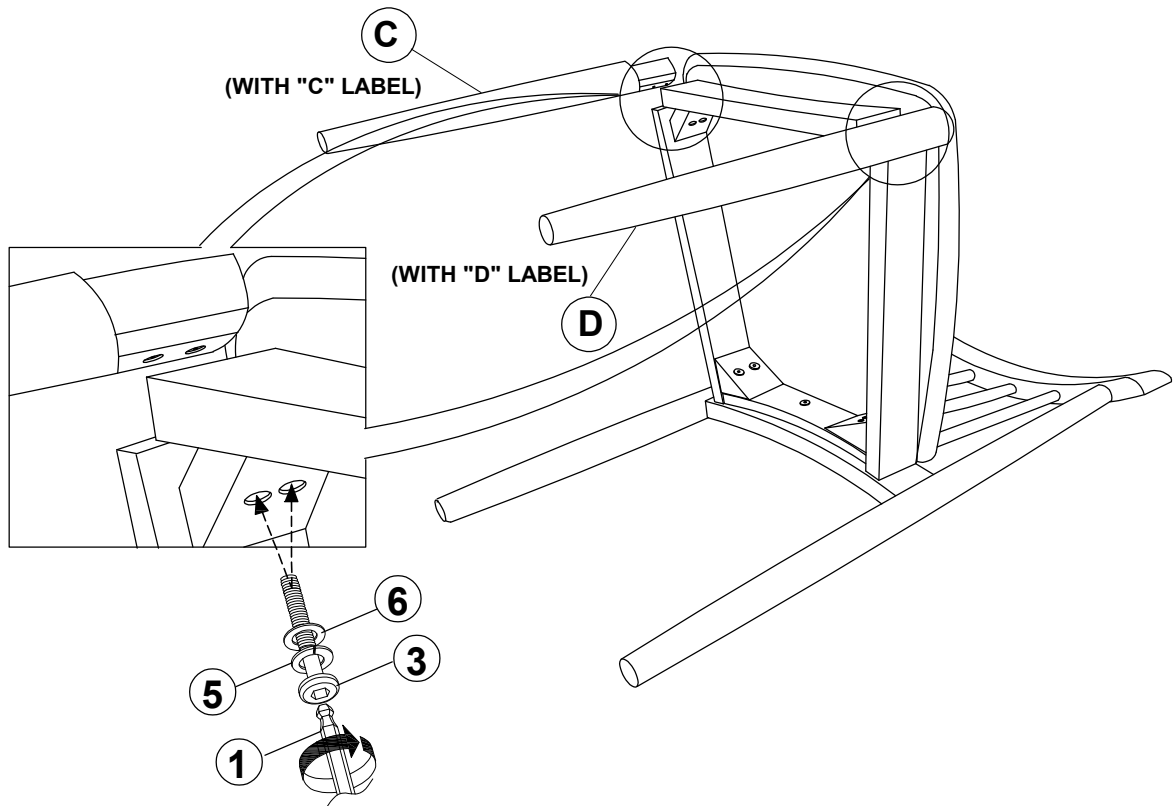

STEP 4
COMPLETE

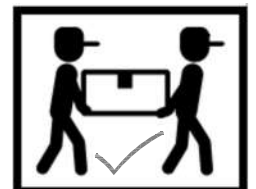
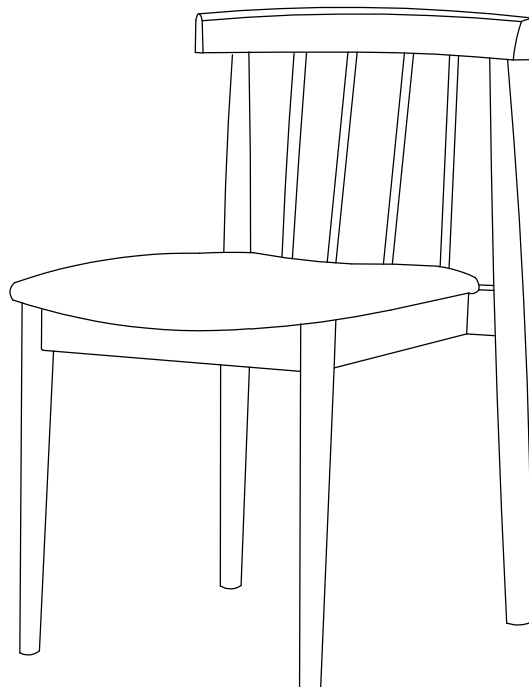

ITEM: **193942WAL**

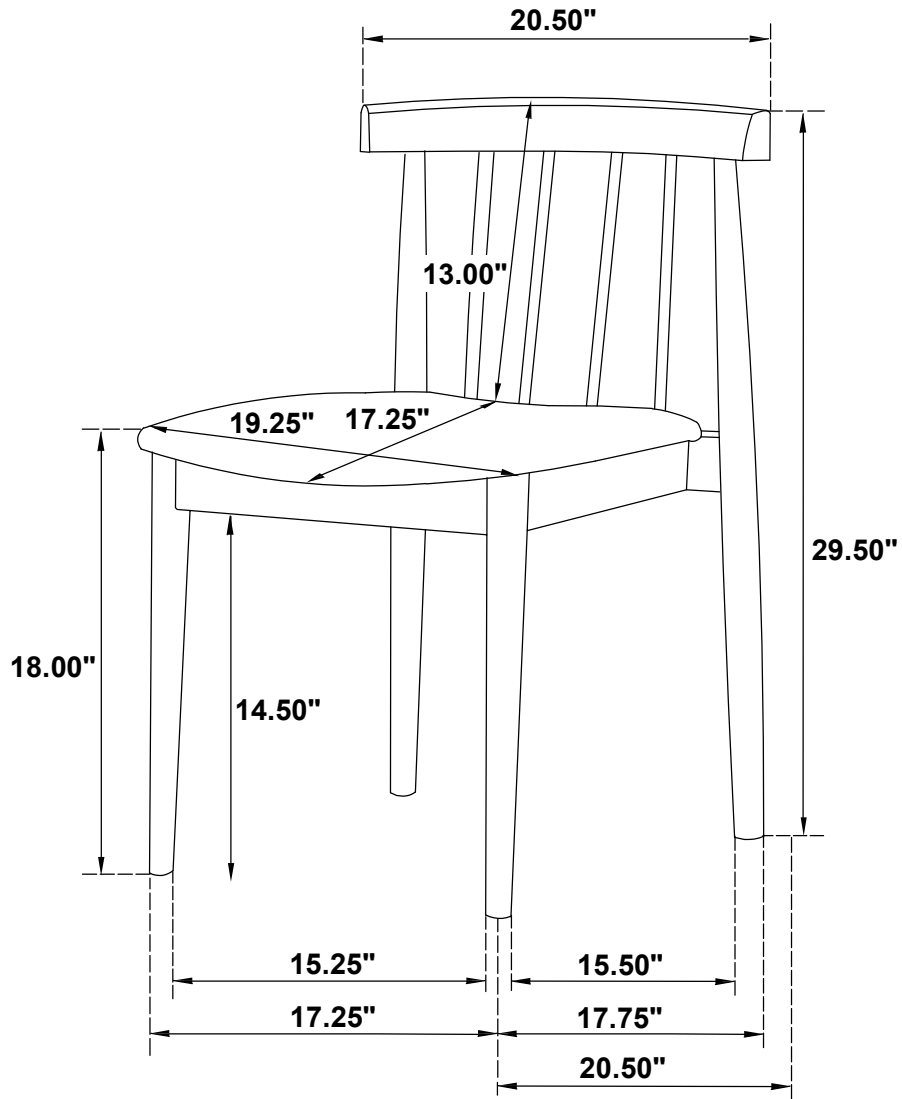

Note: Dimension tolerance $\pm 5\%$