

ASSEMBLY INSTRUCTIONS
COASTER FINE FURNITURE



Fine Furniture for every stage of life

212425
Chest

REVISION 0 : 10/16/2017
REVISION 1 : 12/26/2017
REVISION 2 : 08/09/2018
REVISION 3 : 01/02/2019
REVISION 4 : 12/13/2019

ITEM:212425



ASSEMBLY INSTRUCTIONS

ASSEMBLY TIPS:

1. Remove hardware from box and sort by size.
2. Please check to see that all hardware and parts are present prior to start of assembly.
3. Please follow attached instructions in the same sequence as numbered to assure fast & easy assembly.



WARNING!

1. Don't attempt to repair or modify parts that are broken or defective. Please contact the store immediately.
2. This product is for home use only and not intended for commercial establishments.



ASSEMBLY TIME

5 MINUTES

PARTS IDENTIFICATION

A

CHEST



1PC

B

LEG



4PCS

HARDWARE IDENTIFICATION

1

BOLT
(M6 x 50mm - BLK)



4PCS

2

LOCK WASHER
(1/4" - BLK)



4PCS

3

FLAT WASHER
(1/4"ID x 19mm - BLK)



4PCS

4

ALLEN WRENCH
(M4 x 60mm - BLK)



1PC

NOTE:

Phillips head screw driver is required in the assembly process; however, manufacturer does not provide this item.

ITEM:212425

ASSEMBLY INSTRUCTIONS

STEP 1

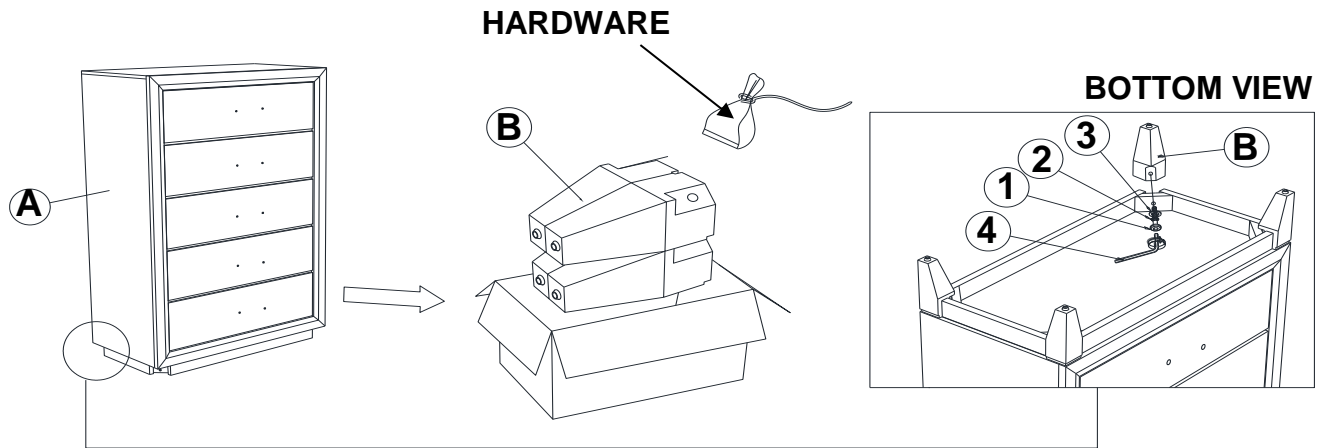

STEP 2

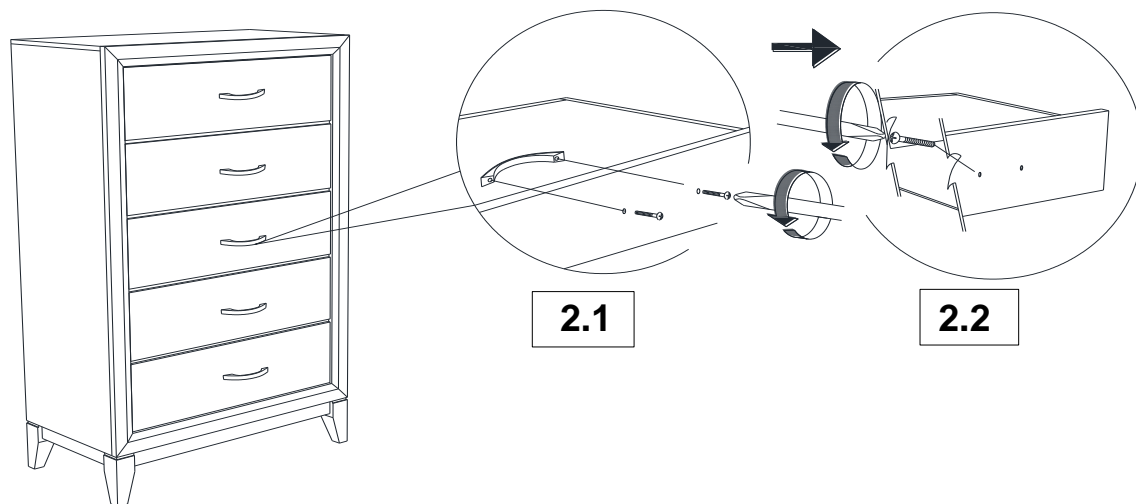

STEP 3
COMPLETE

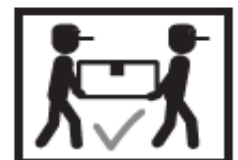

ITEM:212425



Inner Size of Drawer : 25.00"W x 12.50"D x 5.00"H x 0.25"T

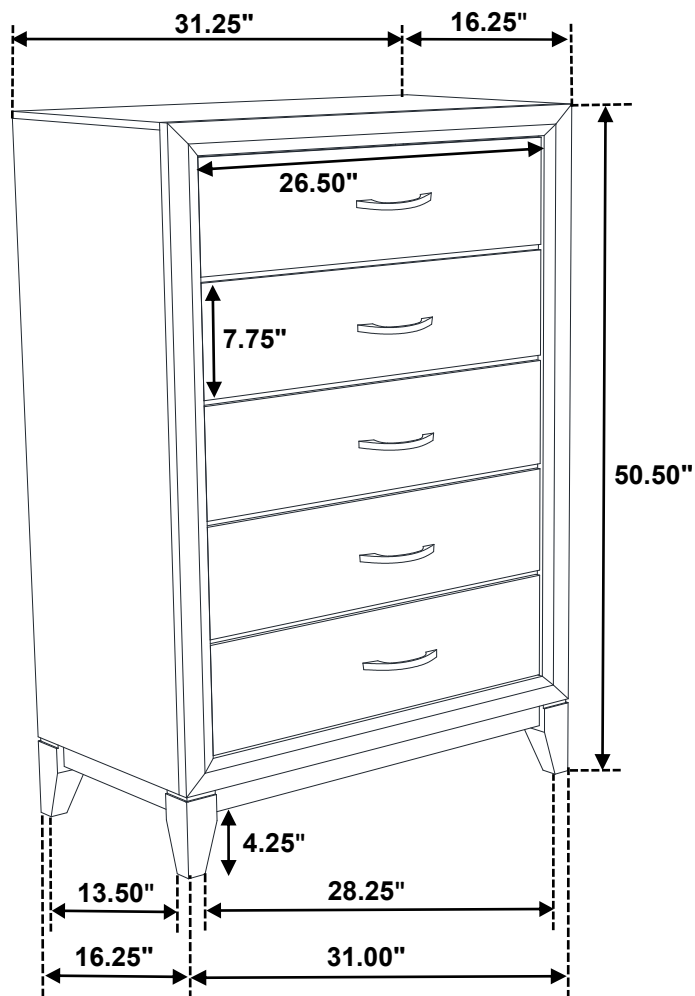

Note : Dimension tolerance $\pm 5\%$