

ASSEMBLY INSTRUCTIONS
COASTER FINE FURNITURE

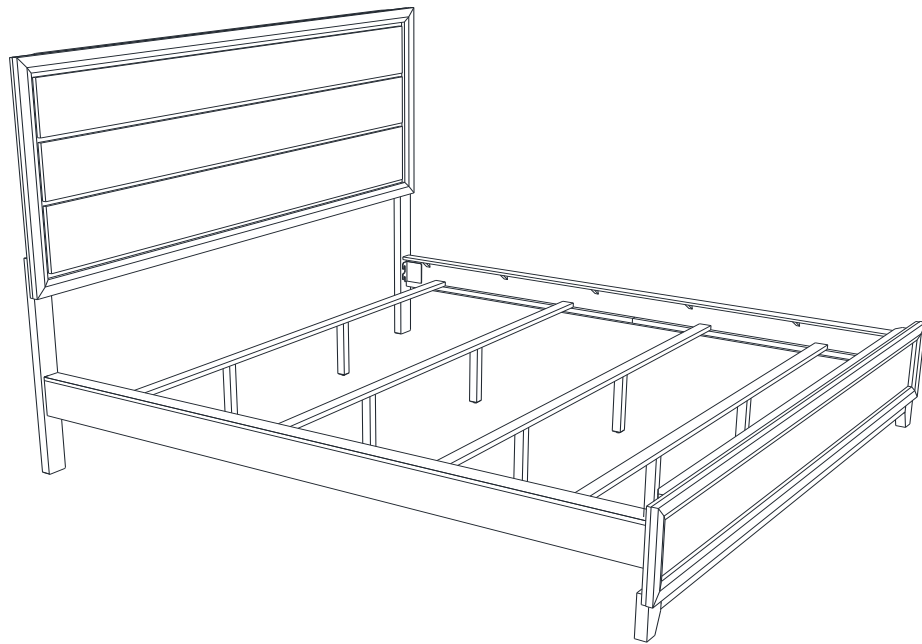

Fine Furniture for every stage of life

215911KW(B1&B2)
California King Bed

ITEM: 215911KW (B1&B2)



ASSEMBLY INSTRUCTIONS

ASSEMBLY TIPS:

1. Remove hardware from box and sort by size.
2. Please check to see that all hardware and parts are present prior to start of assembly.
3. Please follow attached instructions in the same sequence as numbered to assure fast & easy assembly.



WARNING!

1. Don't attempt to repair or modify parts that are broken or defective. Please contact the store immediately.
2. This product is for home use only and not intended for commercial establishments.



ASSEMBLY TIME

20 MINUTES

PARTS IDENTIFICATION

B1 (BOX 1)

A	HEADBOARD PANEL		1PC	D	LEFT HEADBOARD LEG		1PC
B	FOOTBOARD		1PC	E	BED SLAT		4PCS
C	RIGHT HEADBOARD LEG		1PC	F	BED SLAT SUPPORT WITH LEVELER		8PCS

B2 (BOX 2)

G	BED RAIL		2PCS				
HB	215911KW(B1) FROM BOX 1 HEADBOARD COMPLETE		1PC	B	215911KW(B1) FROM BOX 1 FOOTBOARD		1PC

HARDWARE IDENTIFICATION

Z-B1 (BOX 1) - HARDWARE PACK IS LOCATED IN 215911KW (B1)

1	BOLT (M6 x 30mm - BLK)		6PCS	4	SMALL ALLEN WRENCH (M4 x 60mm - BLK)		1PC
2	LOCK WASHER (1/4" - BLK)		6PCS	5	BIG ALLEN WRENCH (M5 x 65mm - BLK)		1PC
3	FLAT WASHER (1/4"ID x 13mm - BLK)		6PCS				

Z-B2 (BOX 2) - HARDWARE PACK IS LOCATED IN 215911KW (B2)

6	PAN HEAD SCREW (M3.5 x 16mm - BLK)		16PCS	7	L-BRACKET		8PCS
---	------------------------------------	--	-------	---	-----------	--	------

NOTE:

Phillips head screw driver is required in the assembly process; however, manufacturer does not provide this item.

ITEM: 215911KW (B1&B2)

ASSEMBLY INSTRUCTIONS

STEP 1

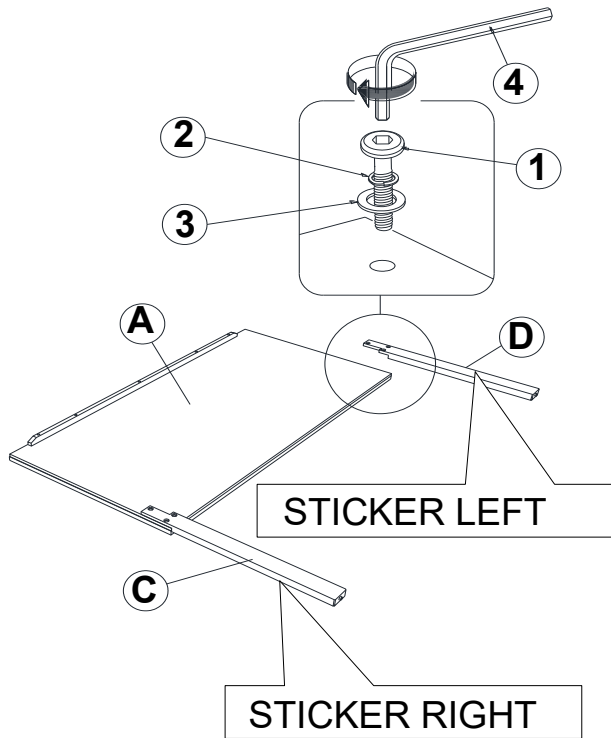

****BACK VIEW****

Note : Please take note of the marking sticker (L & R) on the headboard legs.

STEP 2

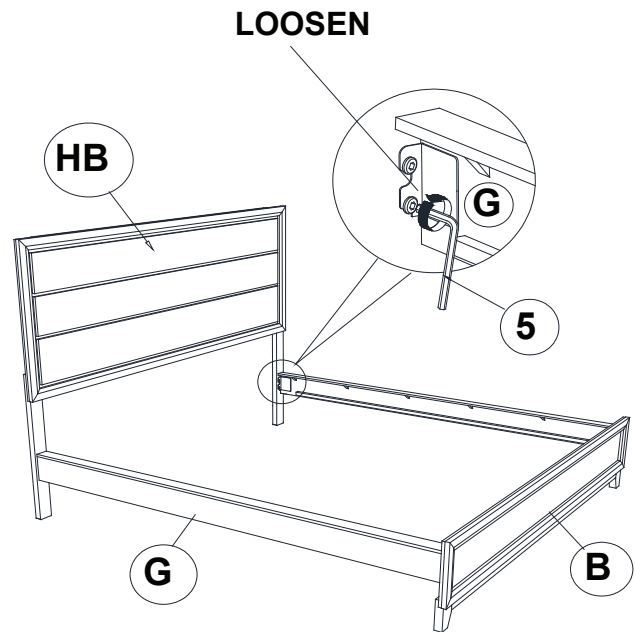

STEP 3

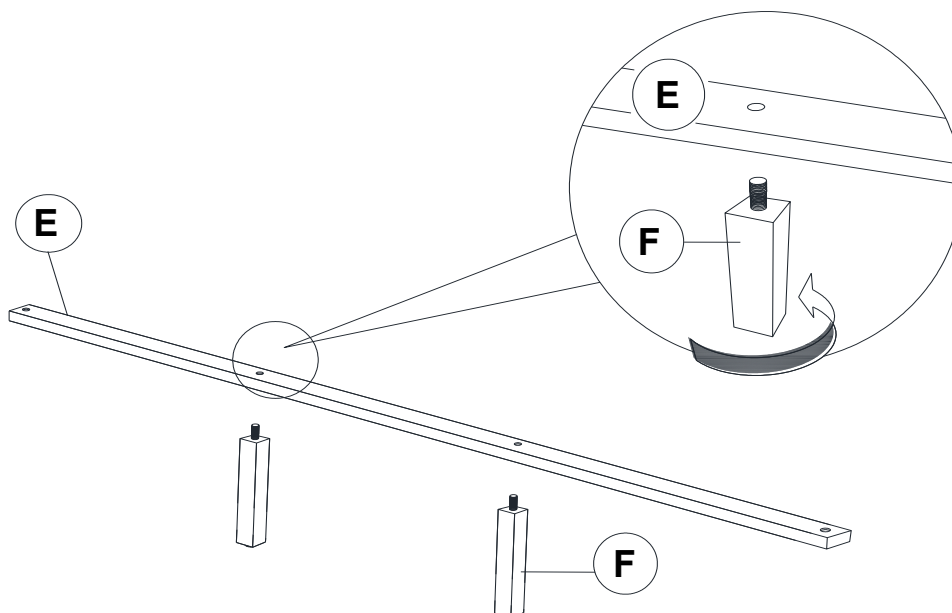

ITEM: 215911KW (B1&B2)



ASSEMBLY INSTRUCTIONS

STEP 4

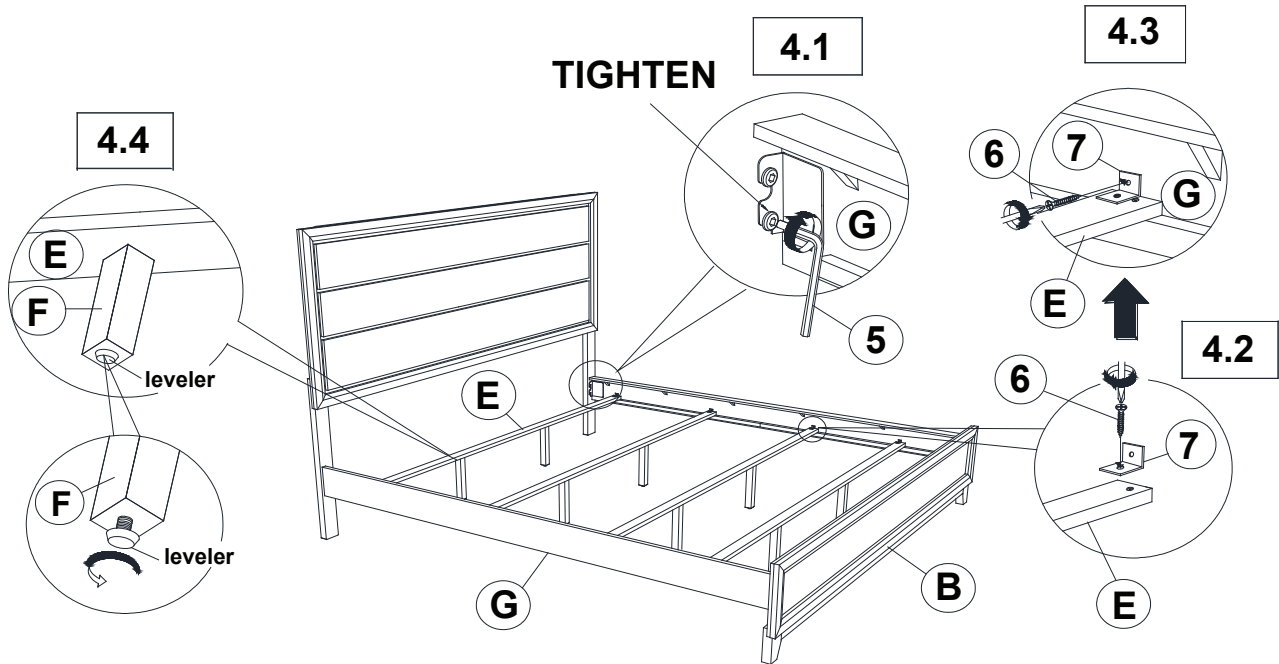

NOTE:

1. Push the side rail inward until the slats are flush and resting on the side rail support then fasten each slat to the side rail support using the provided screw.
2. The side rail warpage is a temporary condition, it will straighten out once the bed is fully assembled.

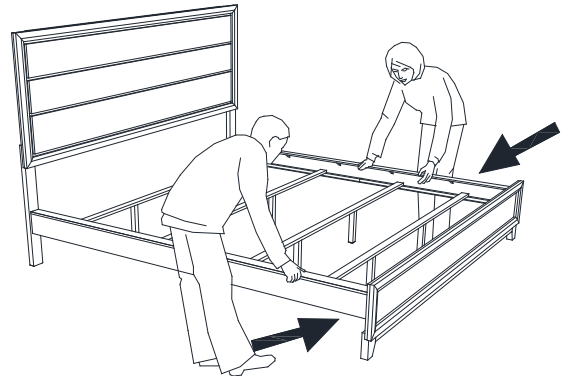

STEP 5 COMPLETE

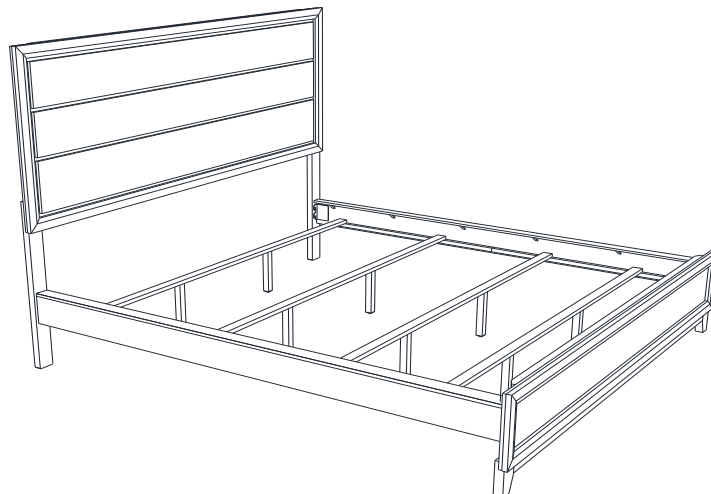

ITEM: 215911KW (B1&B2)



Inner Size : 76.75"W X 86.00"D

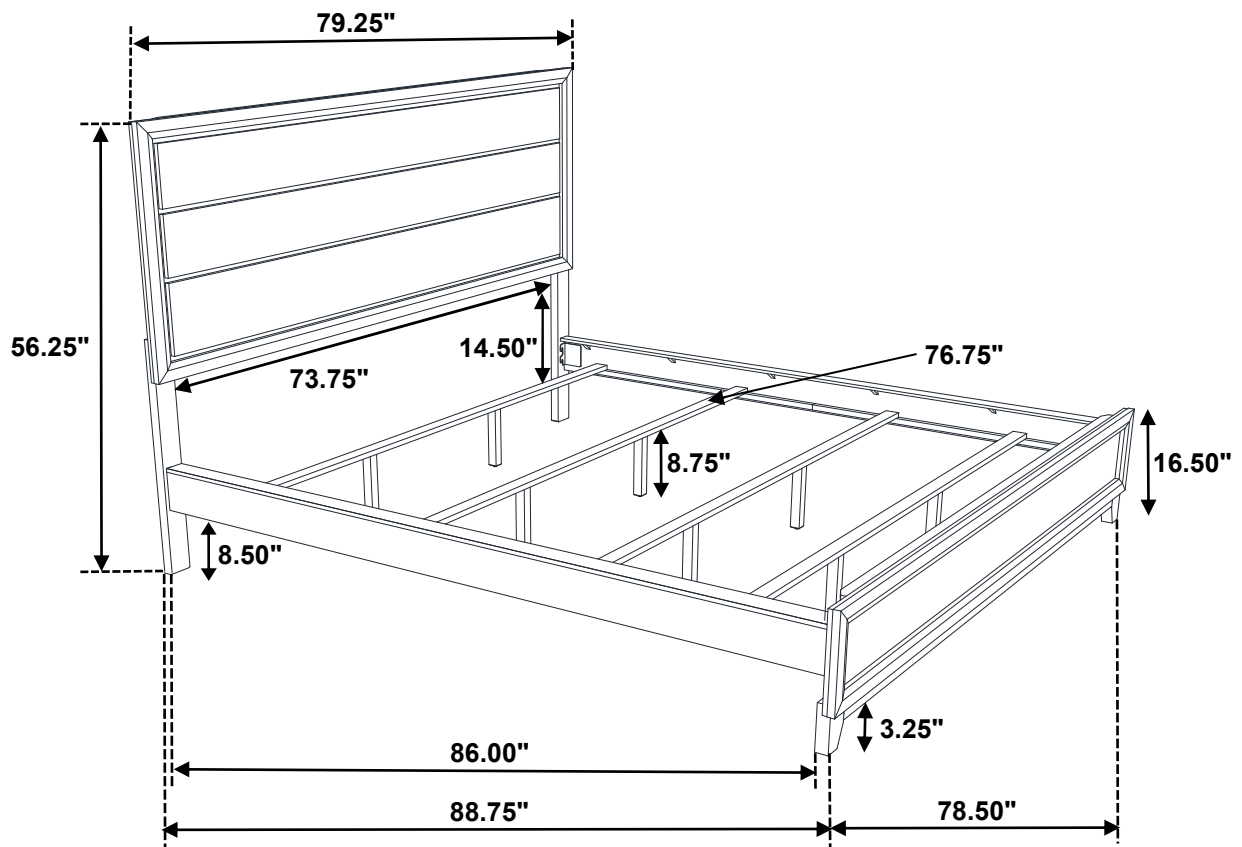

Note : Dimension tolerance $\pm 5\%$

ASSEMBLY INSTRUCTIONS
COASTER FINE FURNITURE



Fine Furniture for every stage of life

215912
Nightstand

ITEM: 215912



ASSEMBLY INSTRUCTIONS

ASSEMBLY TIPS:

1. Remove hardware from box and sort by size.
2. Please check to see that all hardware and parts are present prior to start of assembly.
3. Please follow attached instructions in the same sequence as numbered to assure fast & easy assembly.



WARNING!

1. Don't attempt to repair or modify parts that are broken or defective. Please contact the store immediately.
2. This product is for home use only and not intended for commercial establishments.



ASSEMBLY TIME

5 MINUTES

PARTS IDENTIFICATION

A NIGHTSTAND

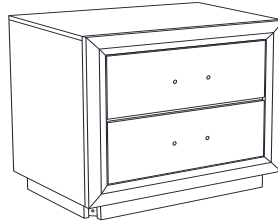

1PC

B LEG



4PCS

HARDWARE IDENTIFICATION

1 BOLT
(M6 x 50mm - BLK)



4PCS

2 LOCK WASHER
(1/4" - BLK)



4PCS

3 FLAT WASHER
(1/4"ID x 19mm - BLK)



4PCS

4 ALLEN WRENCH
(M4 x 60mm - BLK)



1PC

NOTE:

Phillips head screw driver is required in the assembly process; however, manufacturer does not provide this item.

ITEM: **215912**

ASSEMBLY INSTRUCTIONS



STEP 1

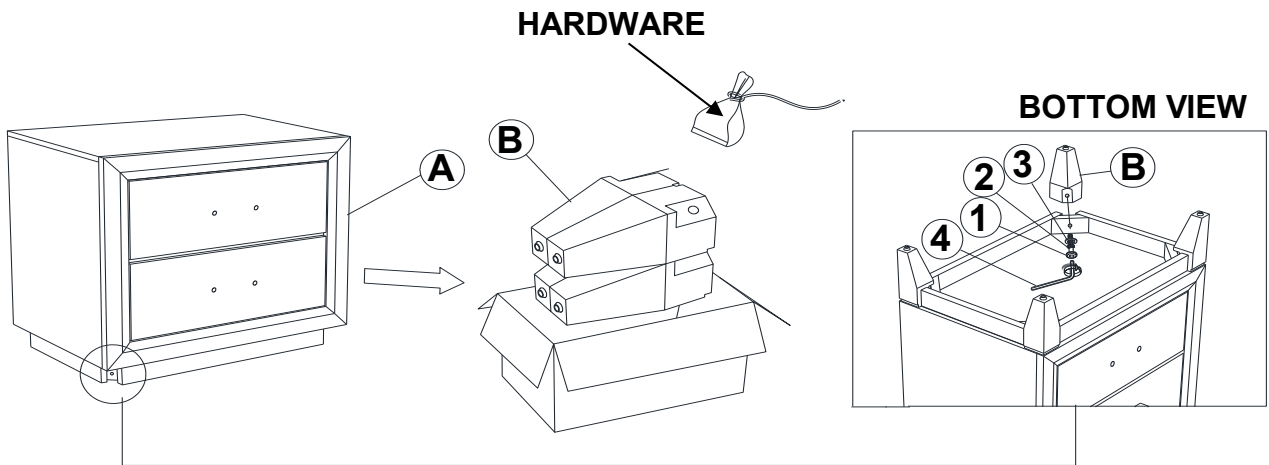

STEP 2

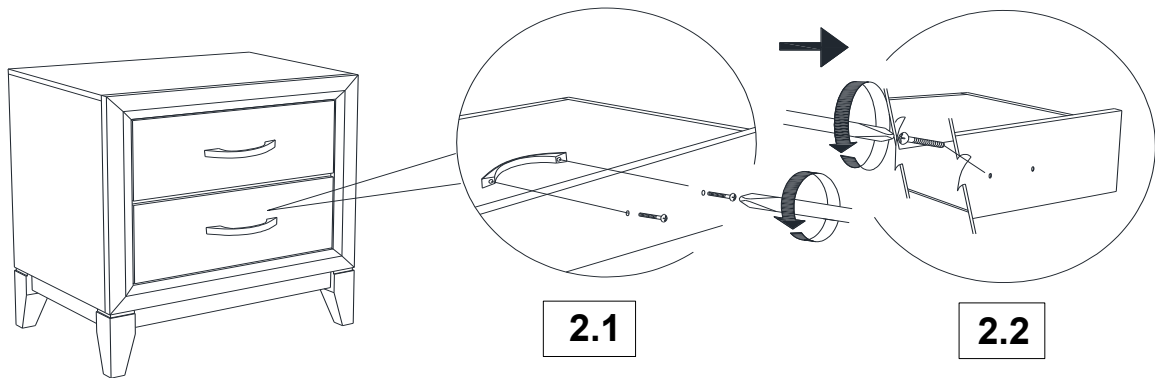

STEP 3
COMPLETE

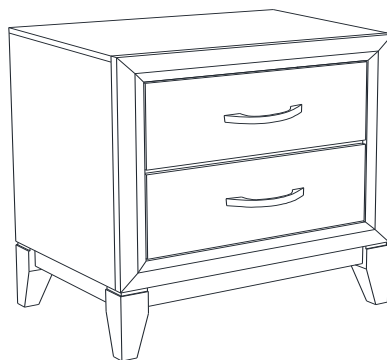

ITEM: **215912**

Inner Size of Drawer : 17.00"W x 12.50"D x 4.00"H x 0.25"T

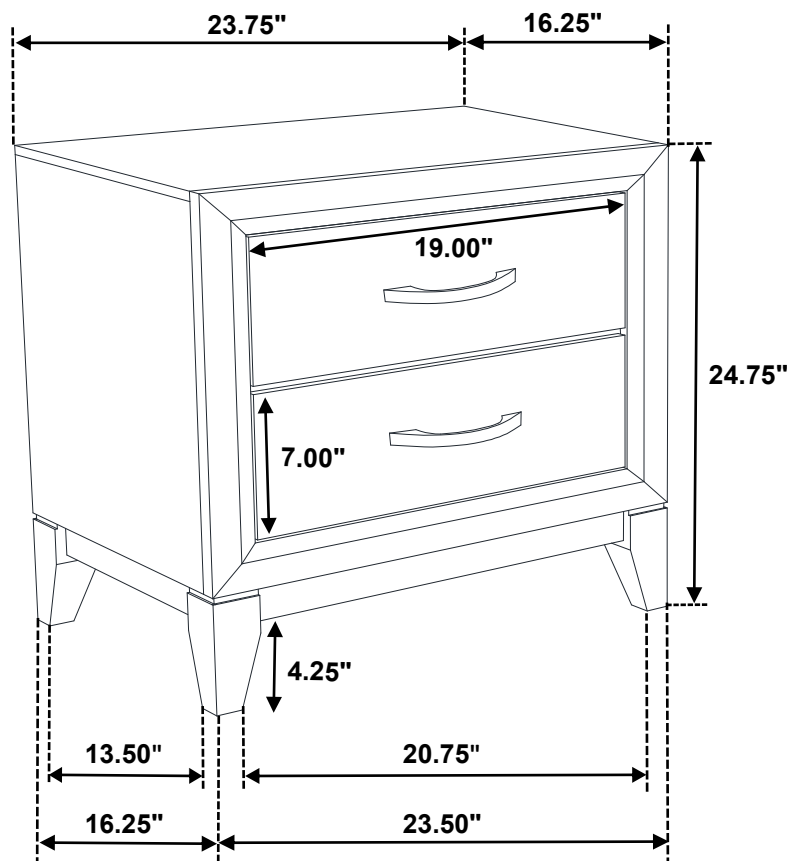

Note : Dimension tolerance $\pm 5\%$

ASSEMBLY INSTRUCTIONS
COASTER FINE FURNITURE



Fine Furniture for every stage of life

215913
Dresser

ITEM: 215913



ASSEMBLY INSTRUCTIONS

ASSEMBLY TIPS:

1. Remove hardware from box and sort by size.
2. Please check to see that all hardware and parts are present prior to start of assembly.
3. Please follow attached instructions in the same sequence as numbered to assure fast & easy assembly.



WARNING!

1. Don't attempt to repair or modify parts that are broken or defective. Please contact the store immediately.
2. This product is for home use only and not intended for commercial establishments.



ASSEMBLY TIME

5 MINUTES

PARTS IDENTIFICATION

A DRESSER

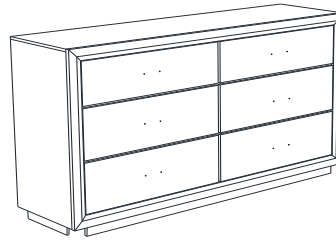

1PC

B LEG



4PCS

C CENTER SUPPORT LEG WITH LEVELER



1PC

HARDWARE IDENTIFICATION

1 BOLT
(M6 x 50mm - BLK)

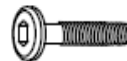

4PCS

2 LOCK WASHER
(1/4" - BLK)



4PCS

3 FLAT WASHER
(1/4"ID x 19mm - BLK)



4PCS

4 ALLEN WRENCH
(M4 x 60mm - BLK)



1PC

NOTE:

Phillips head screw driver is required in the assembly process; however, manufacturer does not provide this item.

ITEM: **215913**

ASSEMBLY INSTRUCTIONS



STEP 1

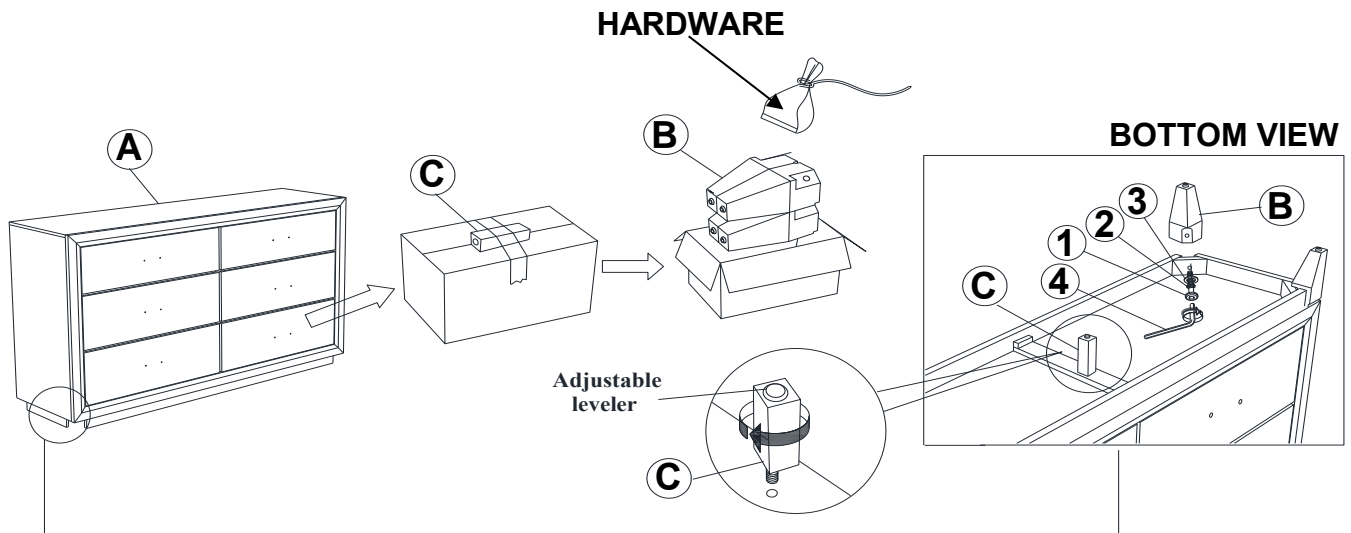

STEP 2

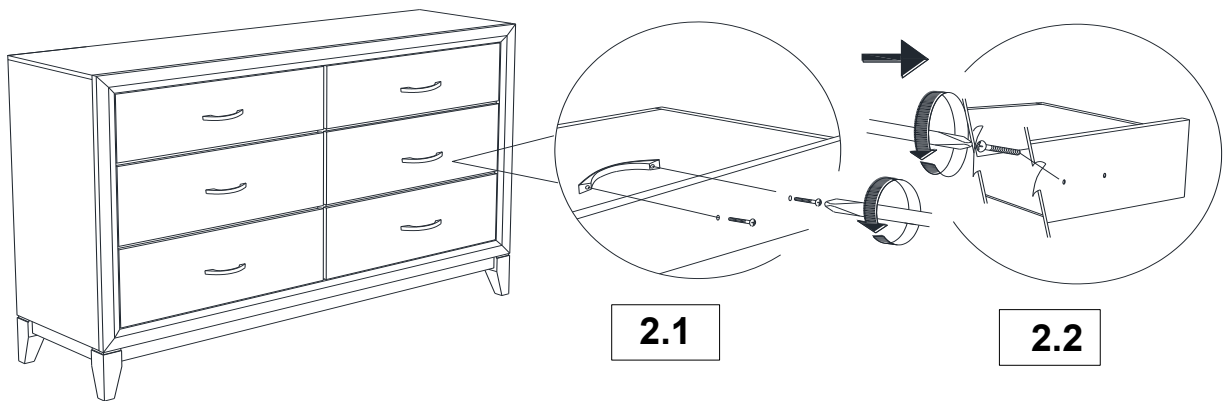

STEP 3
COMPLETE



ITEM: 215913



Inner Size of Drawer : 23.25"W x 12.50"D x 5.00"H x 0.25"H

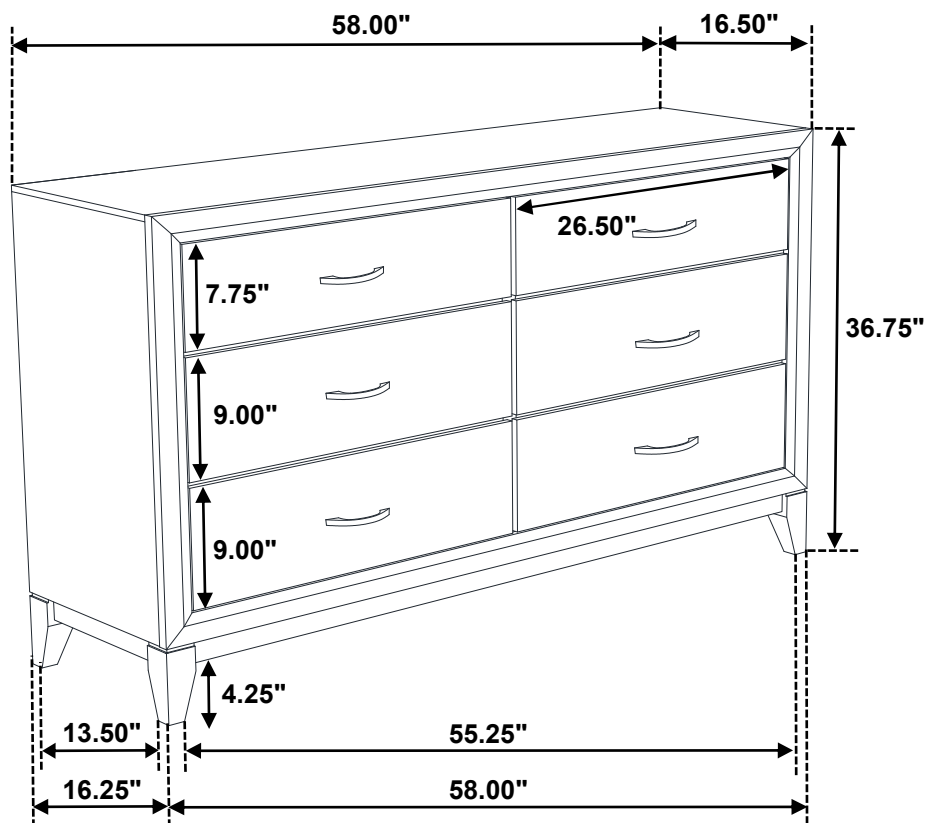

Note : Dimension tolerance $\pm 5\%$

ASSEMBLY INSTRUCTIONS
COASTER FINE FURNITURE



Fine Furniture for every stage of life

215914
Mirror

ITEM: **215914**



ASSEMBLY INSTRUCTIONS

ASSEMBLY TIPS:

1. Remove hardware from box and sort by size.
2. Please check to see that all hardware and parts are present prior to start of assembly.
3. Please follow attached instructions in the same sequence as numbered to assure fast & easy assembly.



WARNING!

1. Don't attempt to repair or modify parts that are broken or defective. Please contact the store immediately.
2. This product is for home use only and not intended for commercial establishments.



ASSEMBLY TIME

10 MINUTES

PARTS IDENTIFICATION

A MIRROR

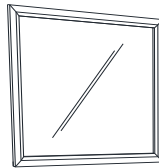

1PC

B DRESSER FROM
BOX ITEM #215913

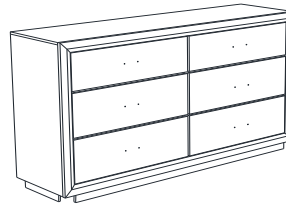

1PC

C MIRROR SUPPORT
(PACK WITH MIRROR)

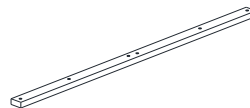

2PCS

HARDWARE IDENTIFICATION

1 FLAT HEAD SCREW
(M4 x 32mm - RBW)



12PCS

NOTE:

Phillips head screw driver is required in the assembly process; however, manufacturer does not provide this item.

ITEM: **215914**

ASSEMBLY INSTRUCTIONS

STEP 1

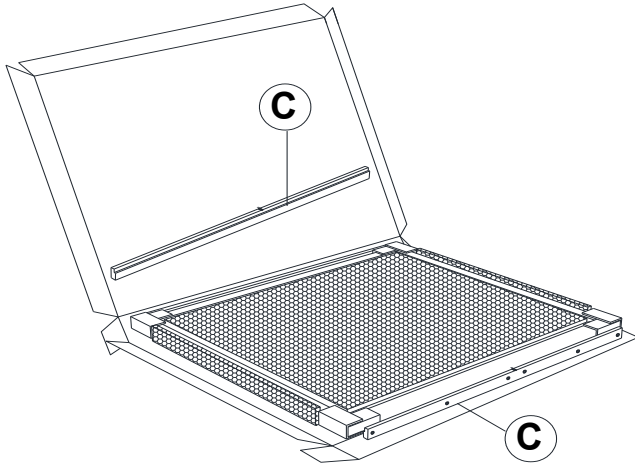

STEP 2

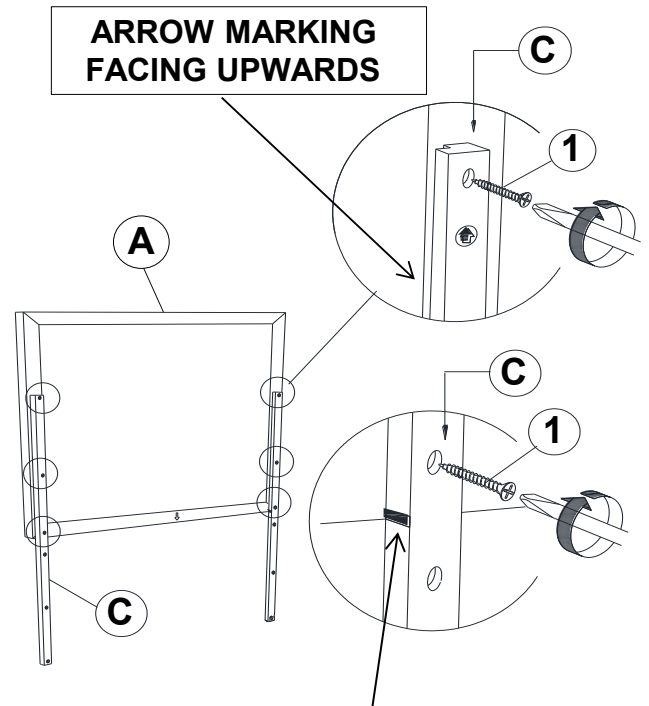

Follow marking line to align the mirror supports

****BACK VIEW****

STEP 3

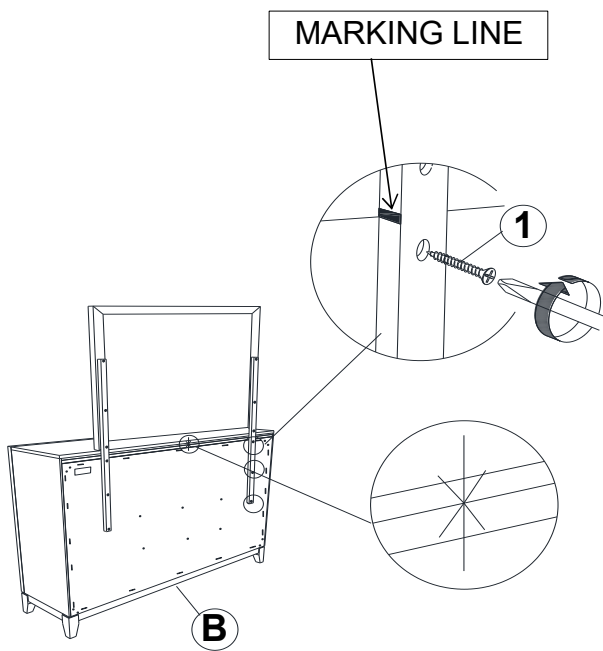

REMARK:
ARROW MARKING MUST BE ALIGNED

STEP 4
COMPLETE

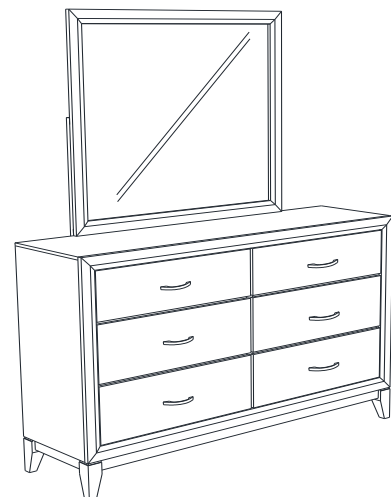

ITEM: **215914**

COASTER
FINE FURNITURE

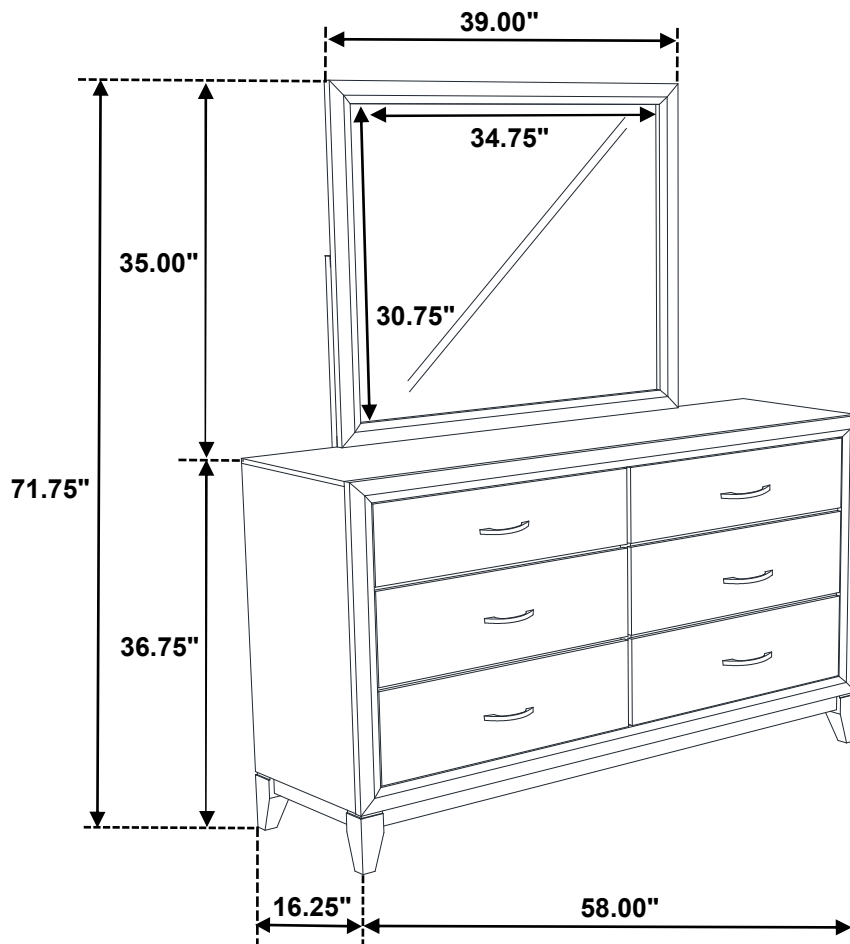

Note : Dimension tolerance $\pm 5\%$

ASSEMBLY INSTRUCTIONS
COASTER FINE FURNITURE



Fine Furniture for every stage of life

215915
Chest

ITEM: **215915**



ASSEMBLY INSTRUCTIONS

ASSEMBLY TIPS:

1. Remove hardware from box and sort by size.
2. Please check to see that all hardware and parts are present prior to start of assembly.
3. Please follow attached instructions in the same sequence as numbered to assure fast & easy assembly.



WARNING!

1. Don't attempt to repair or modify parts that are broken or defective. Please contact the store immediately.
2. This product is for home use only and not intended for commercial establishments.



ASSEMBLY TIME

5 MINUTES

PARTS IDENTIFICATION

A

CHEST



1PC

B

LEG



4PCS

HARDWARE IDENTIFICATION

1

BOLT
(M6 x 50mm - BLK)



4PCS

2

LOCK WASHER
(1/4" - BLK)



4PCS

3

FLAT WASHER
(1/4"ID x 19mm - BLK)



4PCS

4

ALLEN WRENCH
(M4 x 60mm - BLK)

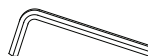

1PC

NOTE:

Phillips head screw driver is required in the assembly process; however, manufacturer does not provide this item.

ITEM: **215915**

ASSEMBLY INSTRUCTIONS



STEP 1

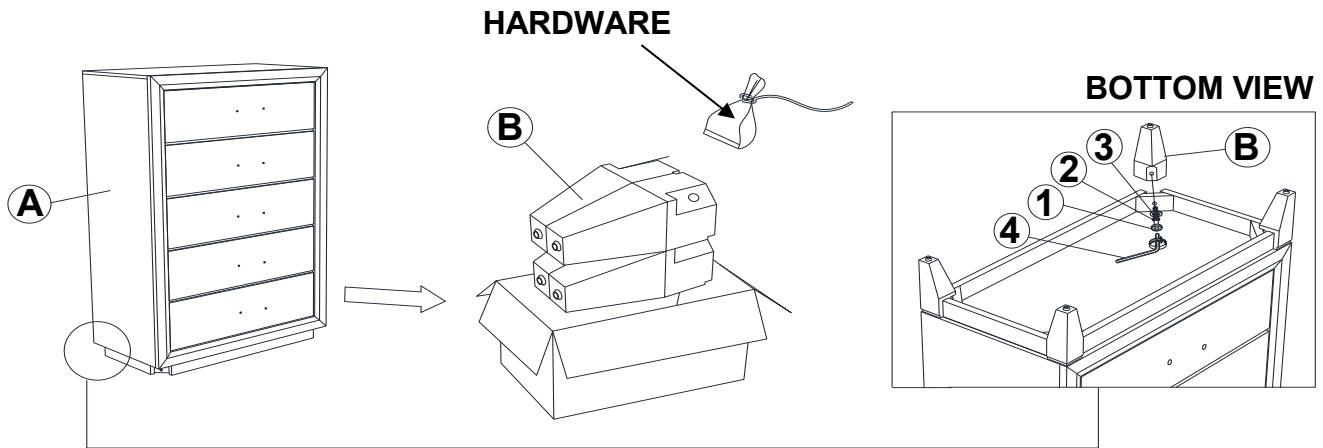

STEP 2

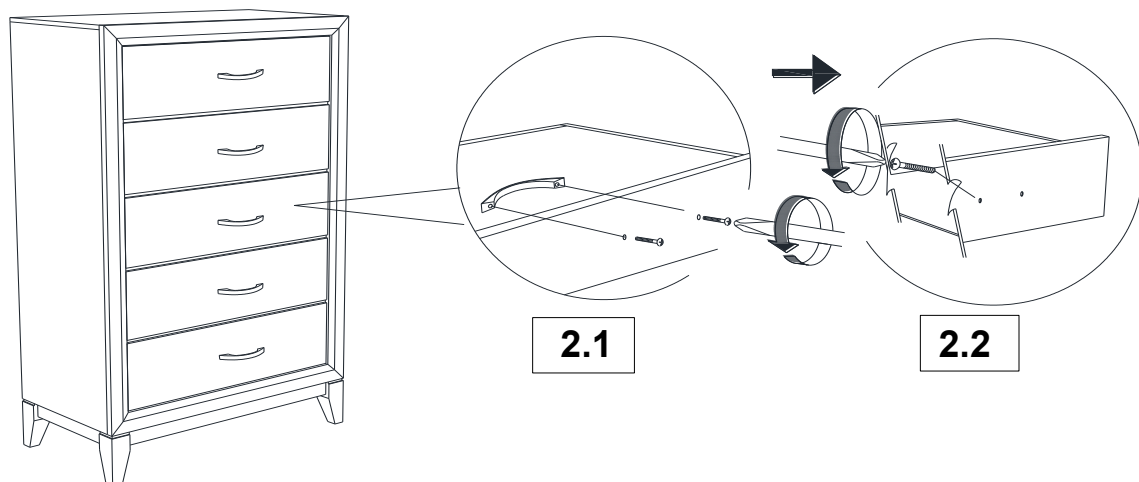

STEP 3
COMPLETE



ITEM: **215915**



Inner Size of Drawer : 25.00"W x 12.50"D x 5.00"H x 0.25"T

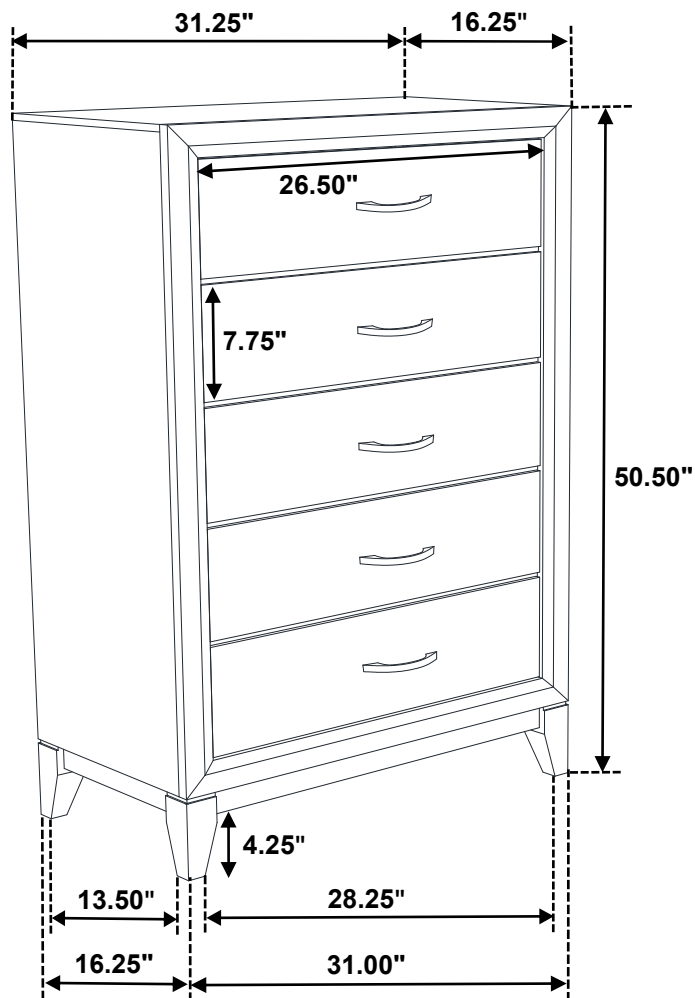

Note : Dimension tolerance $\pm 5\%$