

**ASSEMBLY INSTRUCTIONS**  
**COASTER FINE FURNITURE**

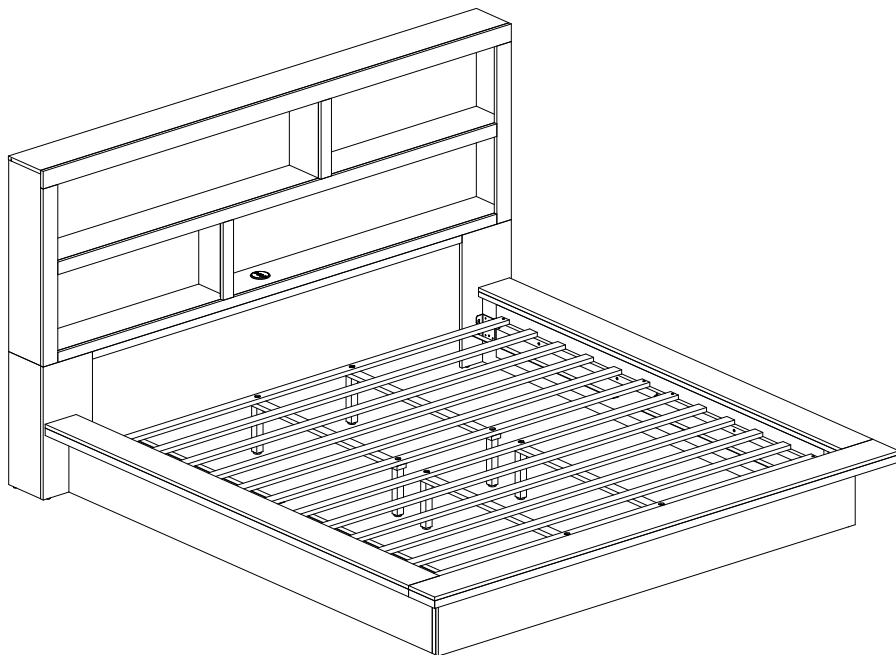

*Fine Furniture for every stage of life*

**222650KW(B1&B2)**  
**California King Bed**

# ITEM: 222650KW (B1&B2)



## ASSEMBLY INSTRUCTIONS

### ASSEMBLY TIPS:

1. Remove hardware from box and sort by size.
2. Please check to see that all hardware and parts are present prior to start of assembly.
3. Please follow attached instructions in the same sequence as numbered to assure fast & easy assembly.



### WARNING!

1. Don't attempt to repair or modify parts that are broken or defective. Please contact the store immediately.
2. This product is for home use only and not intended for commercial establishments.







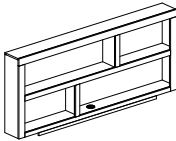
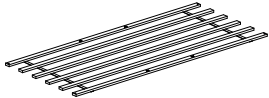

ASSEMBLY TIME

30 MINUTES

## PARTS IDENTIFICATION

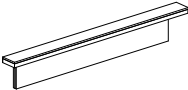
### B1 (BOX 1)

A	HEADBOARD PANEL		1PC	E	ROLL SLAT (6PCS)		2SETS
B	LEFT HEADBOARD LEG (WITH "L" LABEL)		1PC	F	CENTER RAIL		4PCS
C	RIGHT HEADBOARD LEG (WITH "R" LABEL)		1PC	G	CENTER RAIL SUPPORT WITH LEVELER		8PCS
D	FOOTBOARD		1PC	I	ADAPTER		1PC

### B2 (BOX 2)

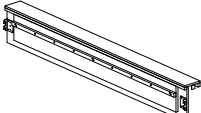
H	BED RAIL		2PCS
---	----------	---	------

# ITEM: 222650KW (B1&B2)



## ASSEMBLY INSTRUCTIONS

### ASSEMBLY TIPS:

1. Remove hardware from box and sort by size.
2. Please check to see that all hardware and parts are present prior to start of assembly.
3. Please follow attached instructions in the same sequence as numbered to assure fast & easy assembly.







### WARNING!

1. Don't attempt to repair or modify parts that are broken or defective. Please contact the store immediately.
2. This product is for home use only and not intended for commercial establishments.

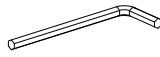
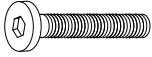
## HARDWARE IDENTIFICATION

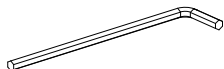
### Z-B1 (BOX 1) - HARDWARE IS LOCATED IN 222650KW (B1)

1	<b>SHORT BOLT</b> (M8 x 16MM - RBW)		8PCS
2	<b>SHORT ALLEN WRENCH</b> (M5 x 68MM - BLK)		1PC
3	<b>LONG BOLT</b> (M6 x 35MM - RBW)		8PCS
4	<b>LOCK WASHER</b> (1/4" x 13Ø - RBW)		8PCS
5	<b>FLAT WASHER</b> (1/4" x 19Ø - RBW)		8PCS
6	<b>LONG ALLEN WRENCH</b> (M4 x 110MM - BLK)		1PC
7	<b>FLAT HEAD SCREW</b> (M4 x 32MM - RBW)		8PCS

### NOTE:

Phillips head screw driver is required in the assembly process; however, manufacturer does not provided this item.

# ITEM: 222650KW (B1&B2)

## ASSEMBLY INSTRUCTIONS

### STEP 1

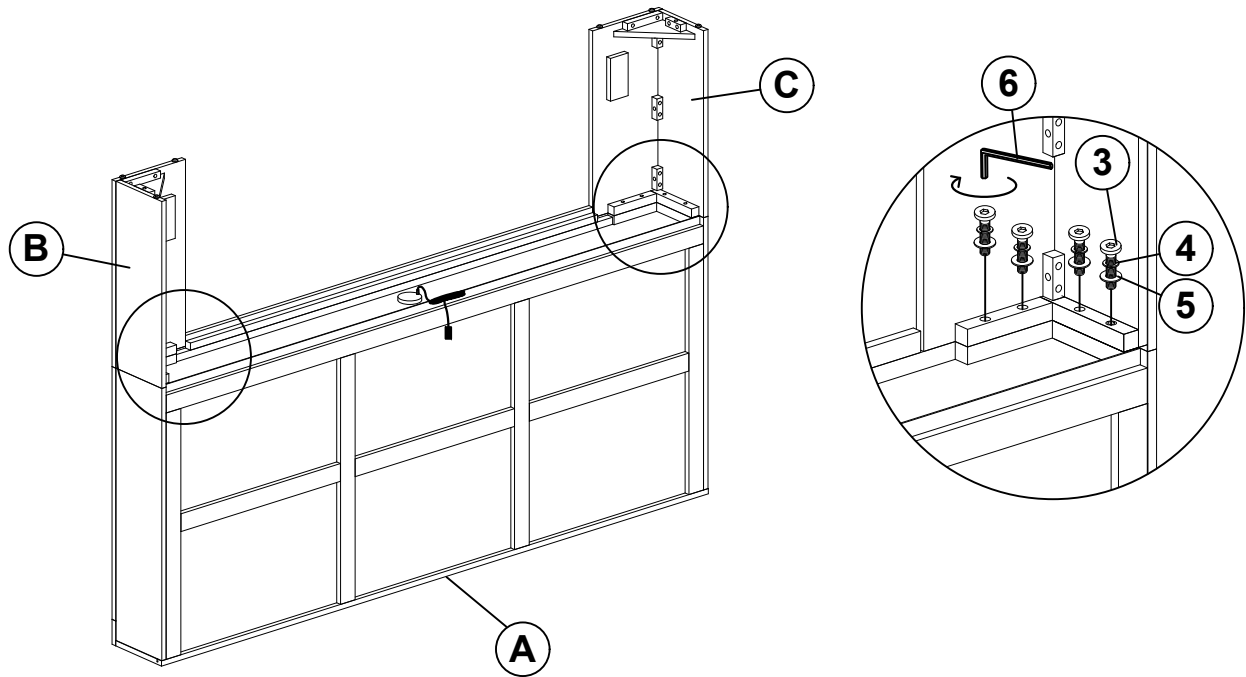

**\*\* BACK VIEW**

### STEP 2

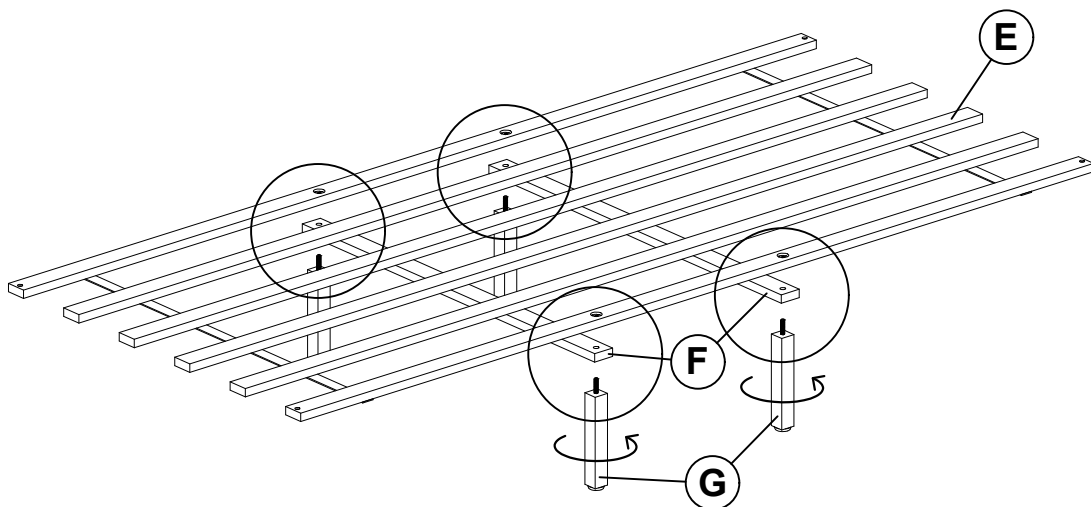

# ITEM: 222650KW (B1&B2)

## ASSEMBLY INSTRUCTIONS

### STEP 3

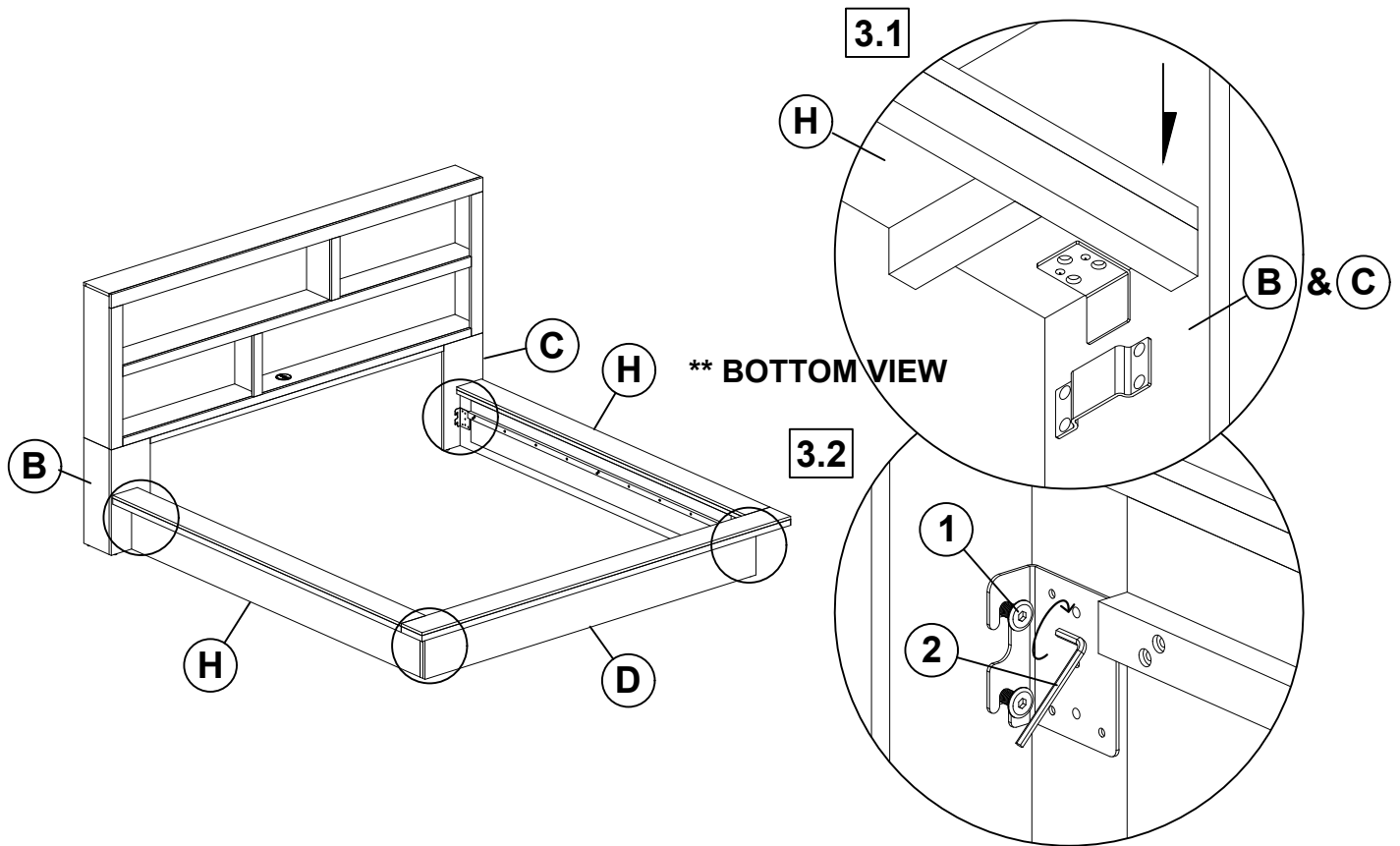

### STEP 4

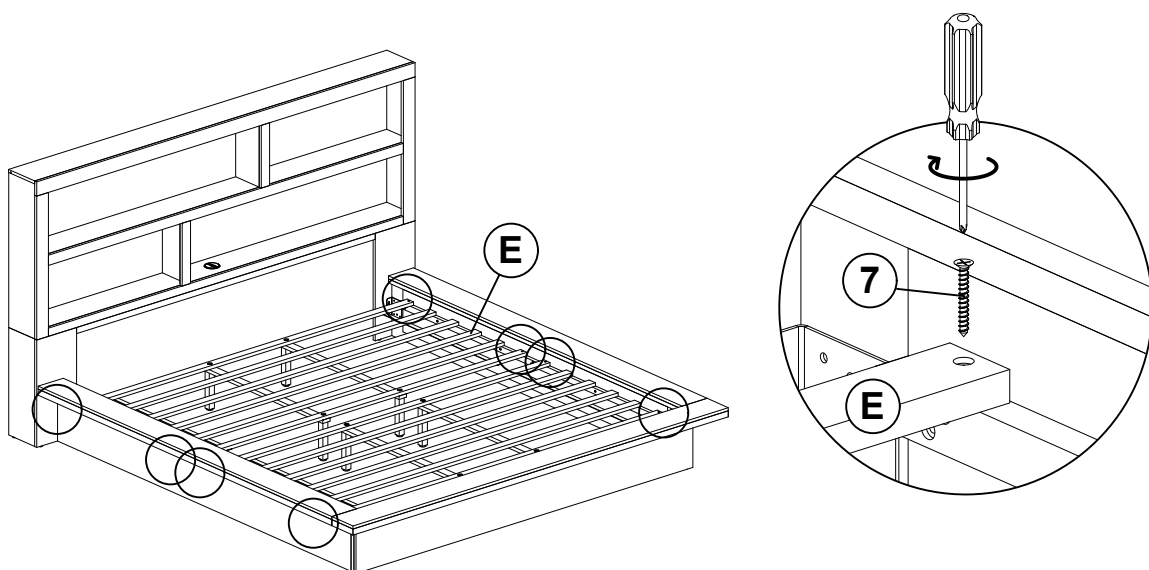

ITEM: **222650KW (B1&B2)**



**ASSEMBLY INSTRUCTIONS**

**STEP 5**

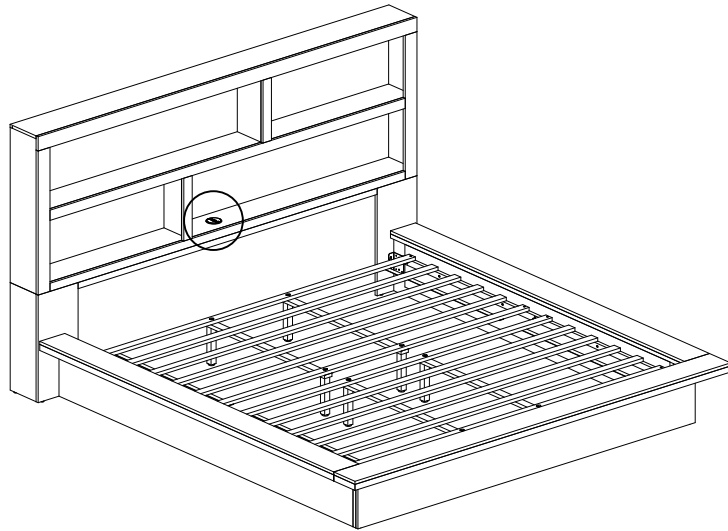
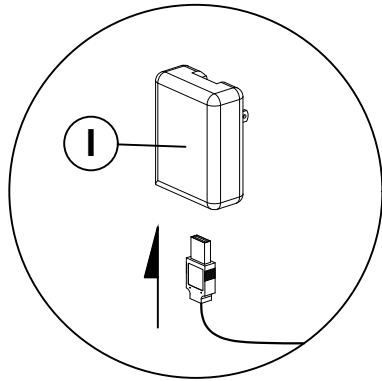

**STEP 6**  
**COMPLETE**

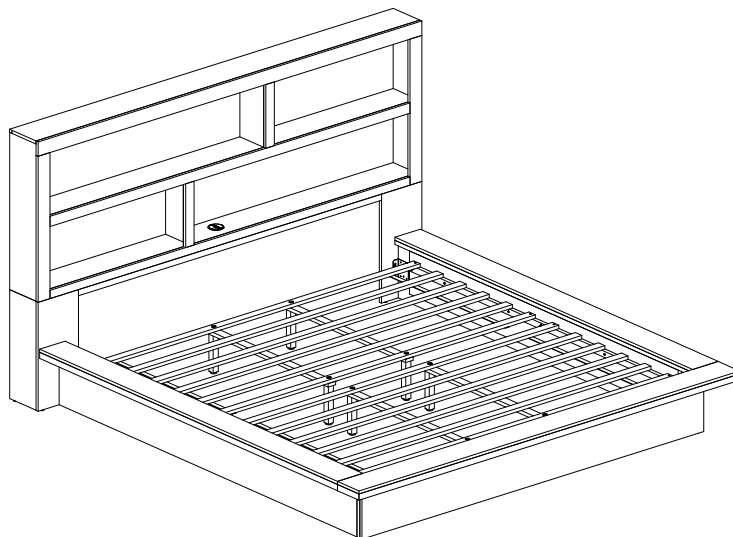



**ASSEMBLY INSTRUCTIONS**  
**COASTER FINE FURNITURE**

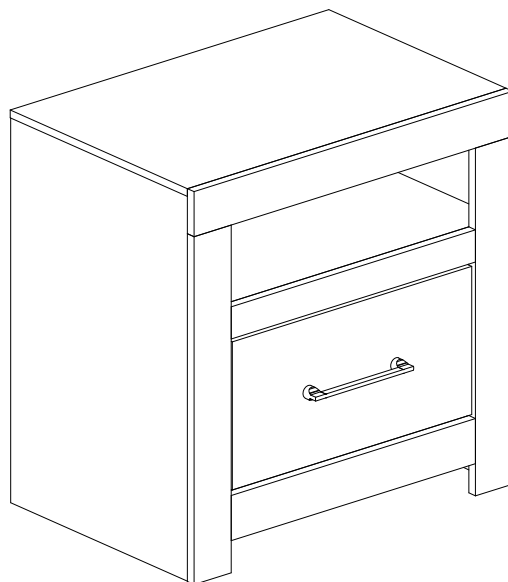

*Fine Furniture for every stage of life*

**222652**  
**Nightstand**

ITEM: **222652**



## ASSEMBLY INSTRUCTIONS

### ASSEMBLY TIPS:

1. Remove hardware from box and sort by size.
2. Please check to see that all hardware and parts are present prior to start of assembly.
3. Please follow attached instructions in the same sequence as numbered to assure fast & easy assembly.



### WARNING!

1. Don't attempt to repair or modify parts that are broken or defective. Please contact the store immediately.
2. This product is for home use only and not intended for commercial establishments.



ASSEMBLY TIME

10 MINUTES

## PARTS IDENTIFICATION

A NIGHTSTAND

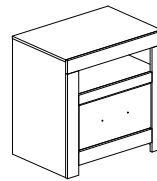

1PC

### NOTE:

Phillips head screw driver is required in the assembly process; however, manufacturer does not provided this item.

ITEM: **222652**

**ASSEMBLY INSTRUCTIONS**

**STEP 1**

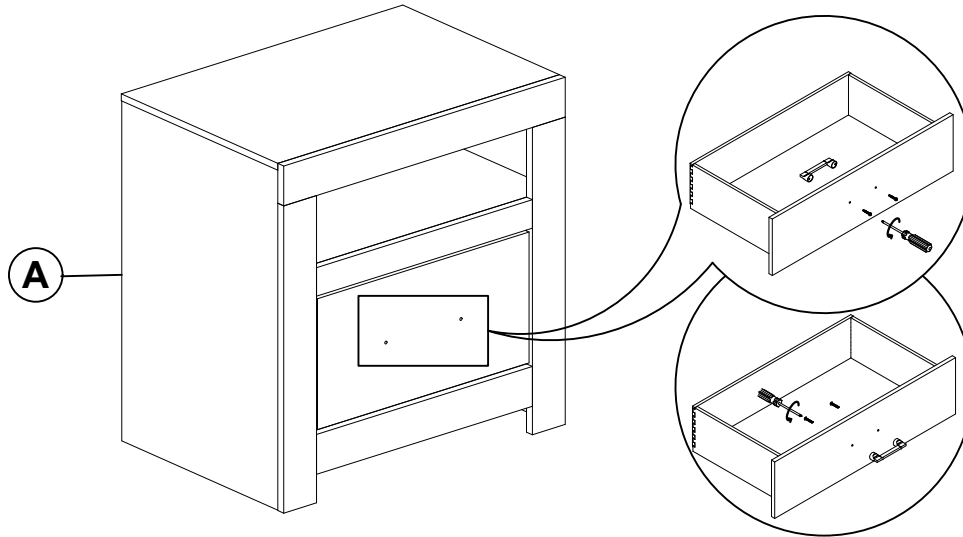

**STEP 2**  
**COMPLETE**

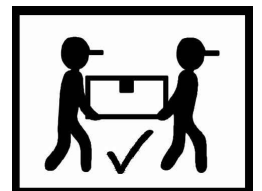
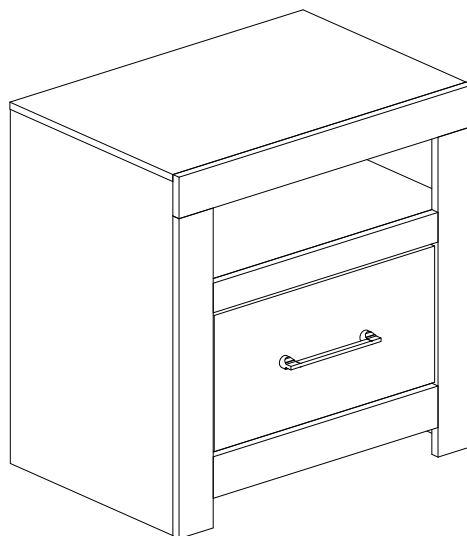

ITEM: **222652**



**Inner Size of Drawer : 16.25"W X 11.75"D X 7.25"H X 0.50"T**

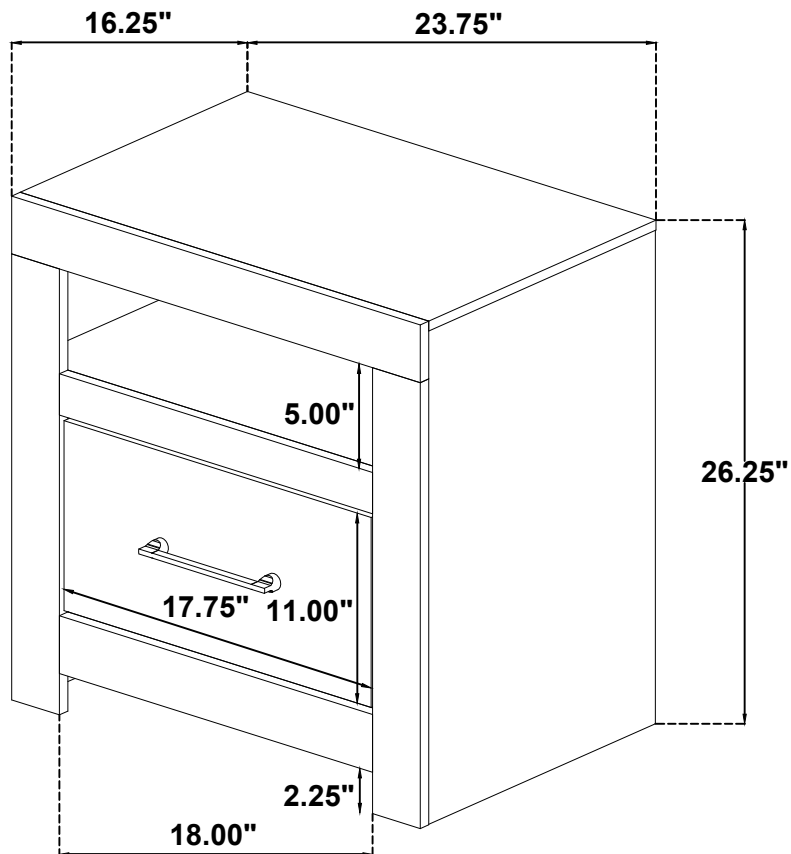

**Note : Dimension tolerance  $\pm 5\%$**

**ASSEMBLY INSTRUCTIONS**  
**COASTER FINE FURNITURE**

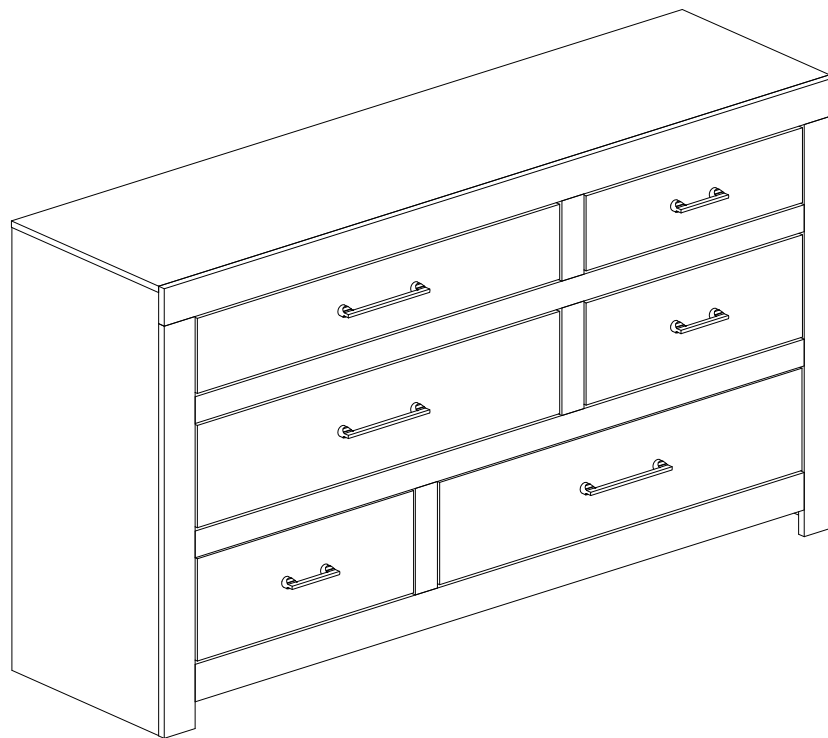

*Fine Furniture for every stage of life*

**222653**  
**Dresser**

ITEM: **222653**



## ASSEMBLY INSTRUCTIONS

### ASSEMBLY TIPS:

1. Remove hardware from box and sort by size.
2. Please check to see that all hardware and parts are present prior to start of assembly.
3. Please follow attached instructions in the same sequence as numbered to assure fast & easy assembly.



### WARNING!

1. Don't attempt to repair or modify parts that are broken or defective. Please contact the store immediately.
2. This product is for home use only and not intended for commercial establishments.



ASSEMBLY TIME

10 MINUTES

## PARTS IDENTIFICATION

A DRESSER

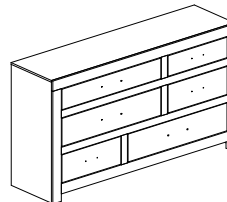

1PC

### NOTE:

Phillips head screw driver is required in the assembly process; however, manufacturer does not provided this item.

ITEM: **222653**



## ASSEMBLY INSTRUCTIONS

### STEP 1

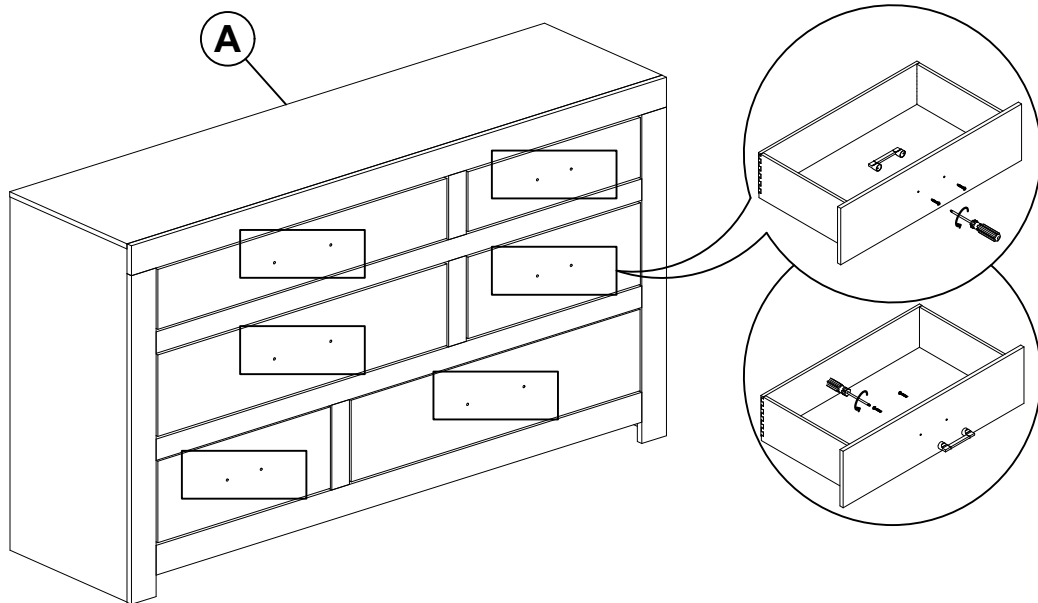

### STEP 2 COMPLETE

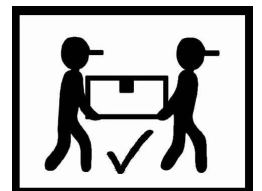
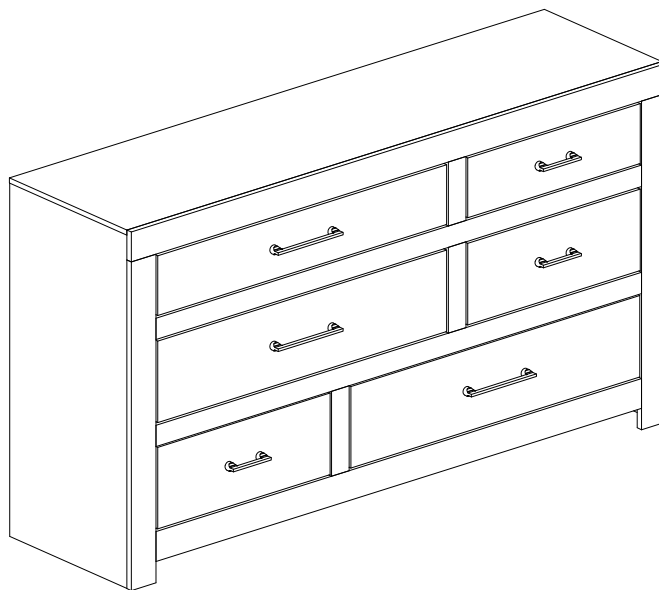

## ANTI-TIPPING INSTALLMENT INSTRUCTIONS FURNITURE TIPPING RESTRAINT

### WARNING

Injury may result from tipping furniture.

This restraint may protect against tipping furniture.

Do not allow children to climb on furniture.

This restraint is not a substitute for proper adult supervision.

Failure to detach this restraint before moving the furniture may result in injury and damage.

1. Attach one of the mounting brackets securely to the back edge of the unit, using the short screw.
2. determine where the unit is to be placed, and mark the location on the wall for the other mounting bracket. The bracket on the wall needs to be approximately 2" below the bracket mounted to the edge of the unit.
3. Drill a hole in the wall. Insert the plastic wall anchor into the hole and if necessary, use a small block of wood and hammer to tap it in so that it's flush with the wall.
4. Attach the bracket over the plastic wall anchor using the long screw.
5. Place the unit against the wall, both brackets need to be placing each other.
6. Lace an end of the restraint strap through the hole in each bracket. Bring both ends together and rotate the thumb nut onto the threaded end until tight.
7. Ensure that the restraint strap is securely laced and locked.

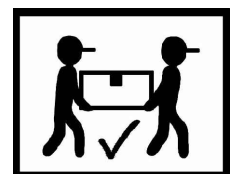
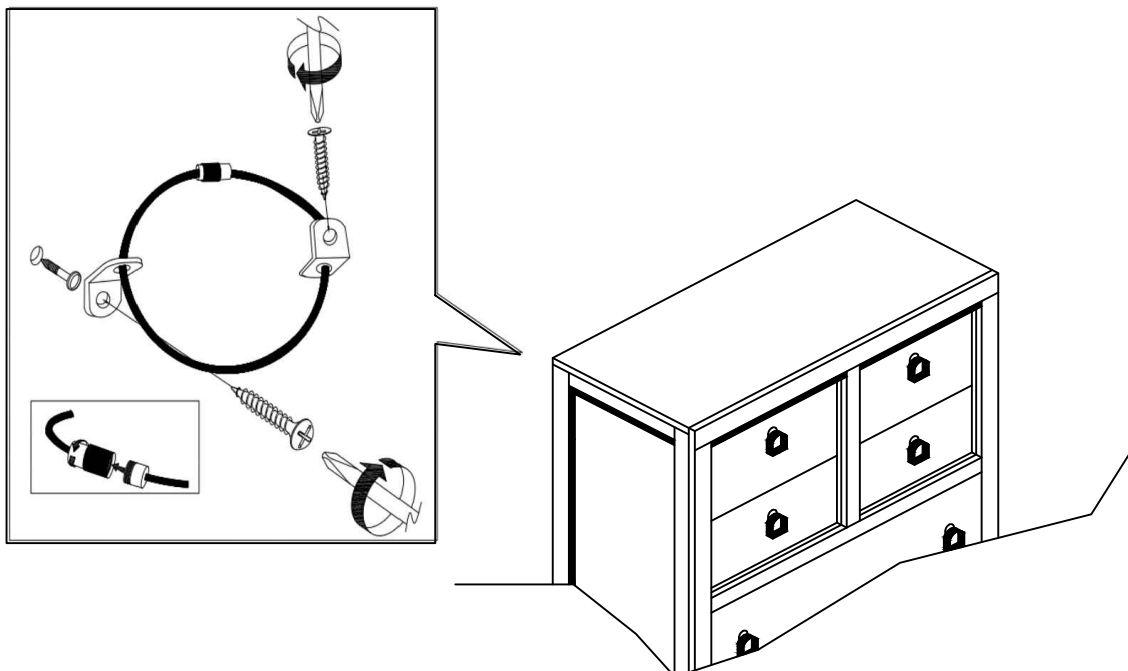

ITEM: **222653**



Inner Size of Drawer A : 40.00"W X 11.75"D X 4.00"H X 0.50"  
Inner Size of Drawer B : 18.00"W X 11.75"D X 4.00"H X 0.50"  
Inner Size of Drawer C : 40.00"W X 11.75"D X 6.00"H X 0.50"  
Inner Size of Drawer D : 18.00"W X 11.75"D X 6.00"H X 0.50"

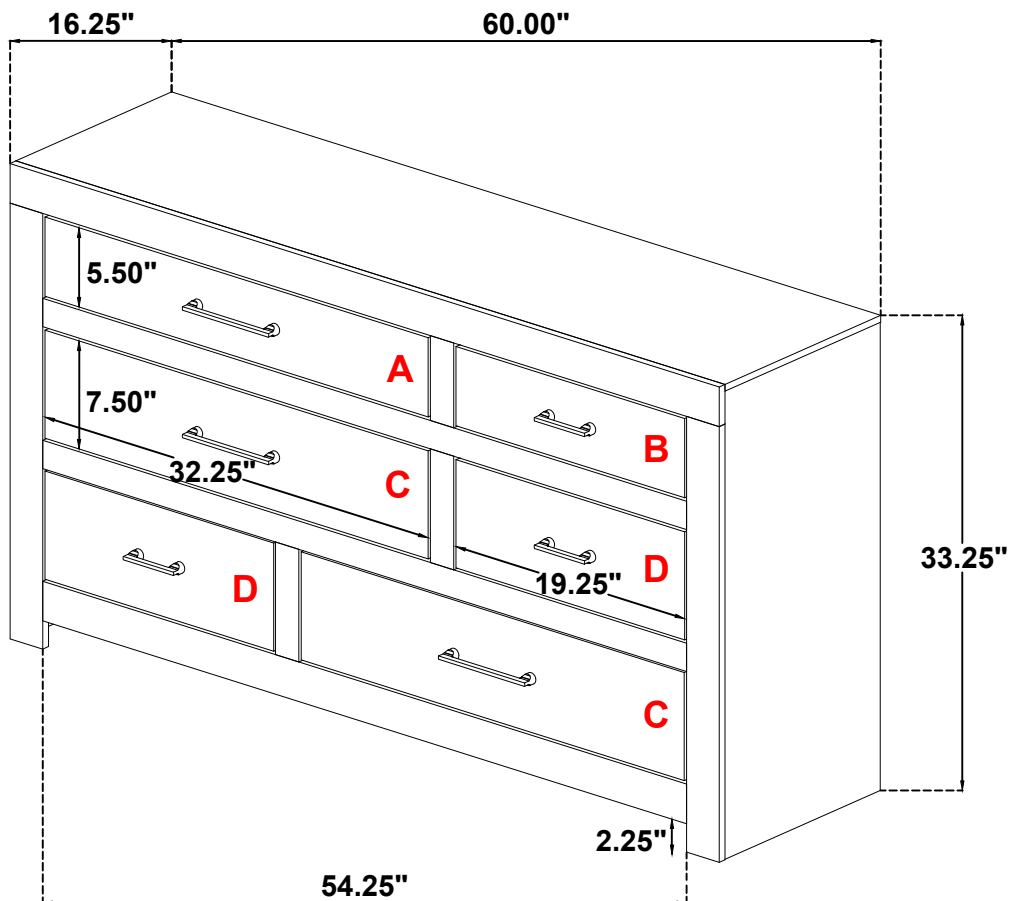

Note : Dimension tolerance  $\pm 5\%$

**ASSEMBLY INSTRUCTIONS**  
**COASTER FINE FURNITURE**

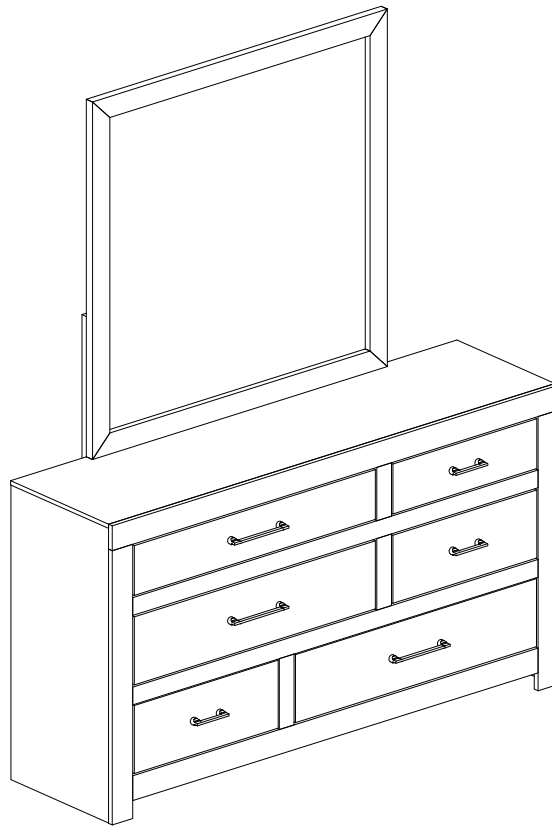

*Fine Furniture for every stage of life*

**222654**  
**Mirror**

ITEM: **222654**



## ASSEMBLY INSTRUCTIONS

### ASSEMBLY TIPS:

1. Remove hardware from box and sort by size.
2. Please check to see that all hardware and parts are present prior to start of assembly.
3. Please follow attached instructions in the same sequence as numbered to assure fast & easy assembly.



### WARNING!

1. Don't attempt to repair or modify parts that are broken or defective. Please contact the store immediately.
2. This product is for home use only and not intended for commercial establishments.



ASSEMBLY TIME

10 MINUTES

## PARTS IDENTIFICATION

A MIRROR

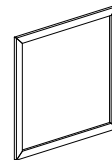

1PC

B MIRROR SUPPORT  
(PACKED WITH MIRROR)

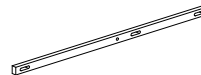

2PCS

C DRESSER  
\*FROM BOX ITEM 222653

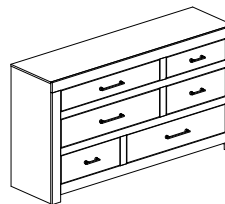

1PC

## HARDWARE IDENTIFICATION

1 BOLT  
(M6 x 40MM - RBW)

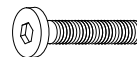

8PCS

2 LOCK WASHER  
(1/4" x 13Ø - RBW)



8PCS

3 FLAT WASHER  
(1/4" x 19Ø - RBW)



8PCS

4 ALLEN WRENCH  
(M4 x 110MM - BLK)



1PC

ITEM: **222654**



**ASSEMBLY INSTRUCTIONS**

**STEP 1**

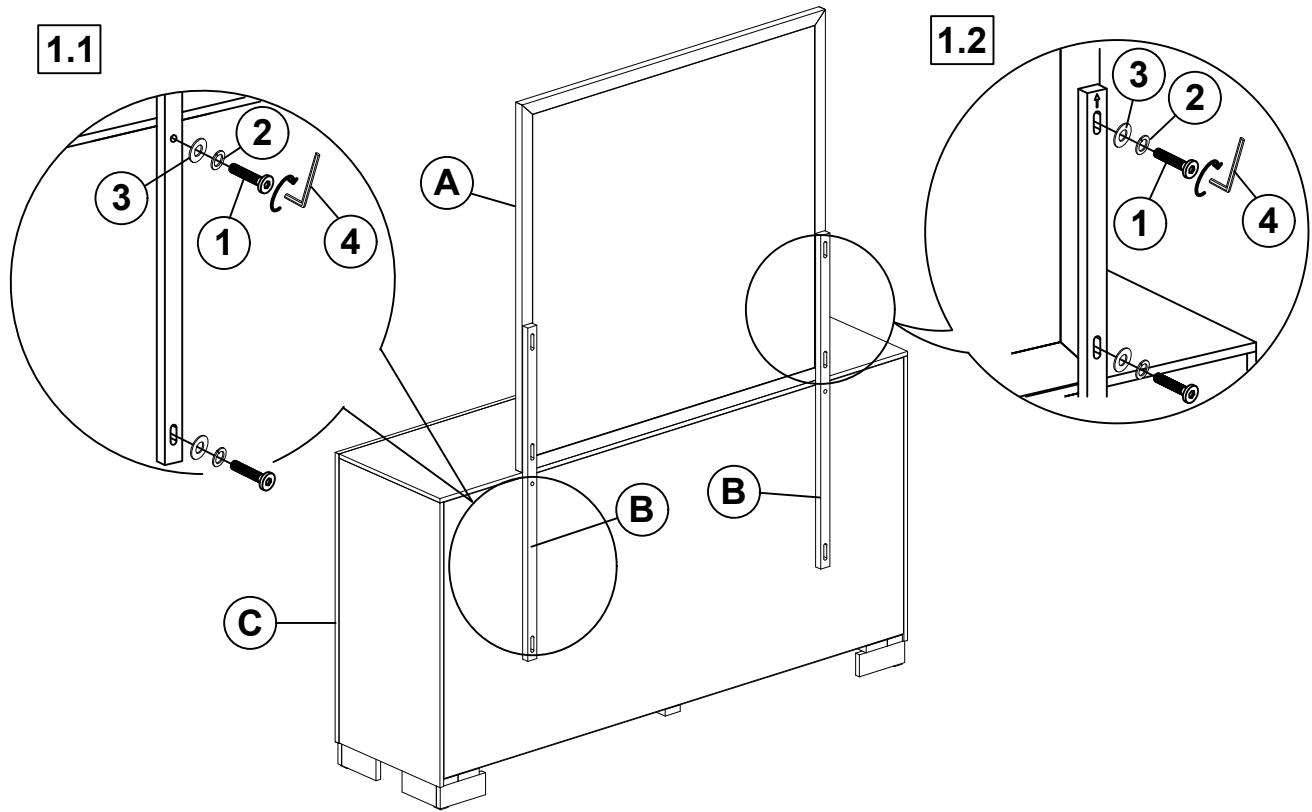

**\*\* BACK VIEW**

**STEP 2  
COMPLETE**

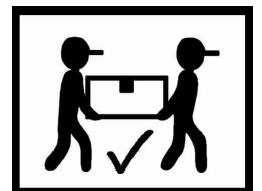
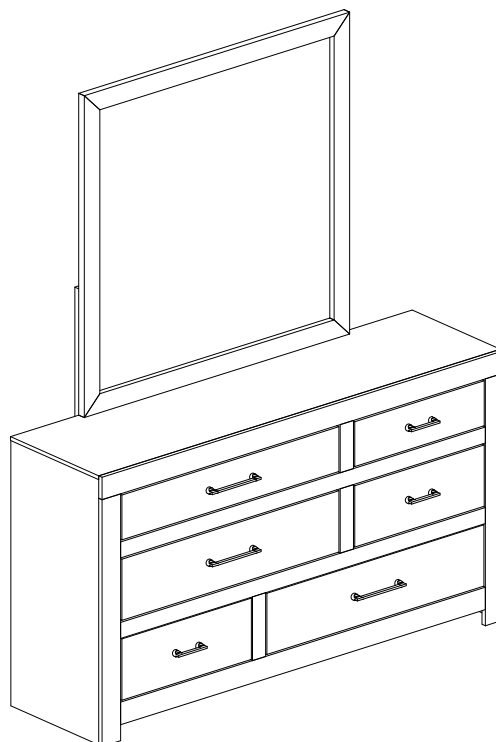

ITEM: **222654**

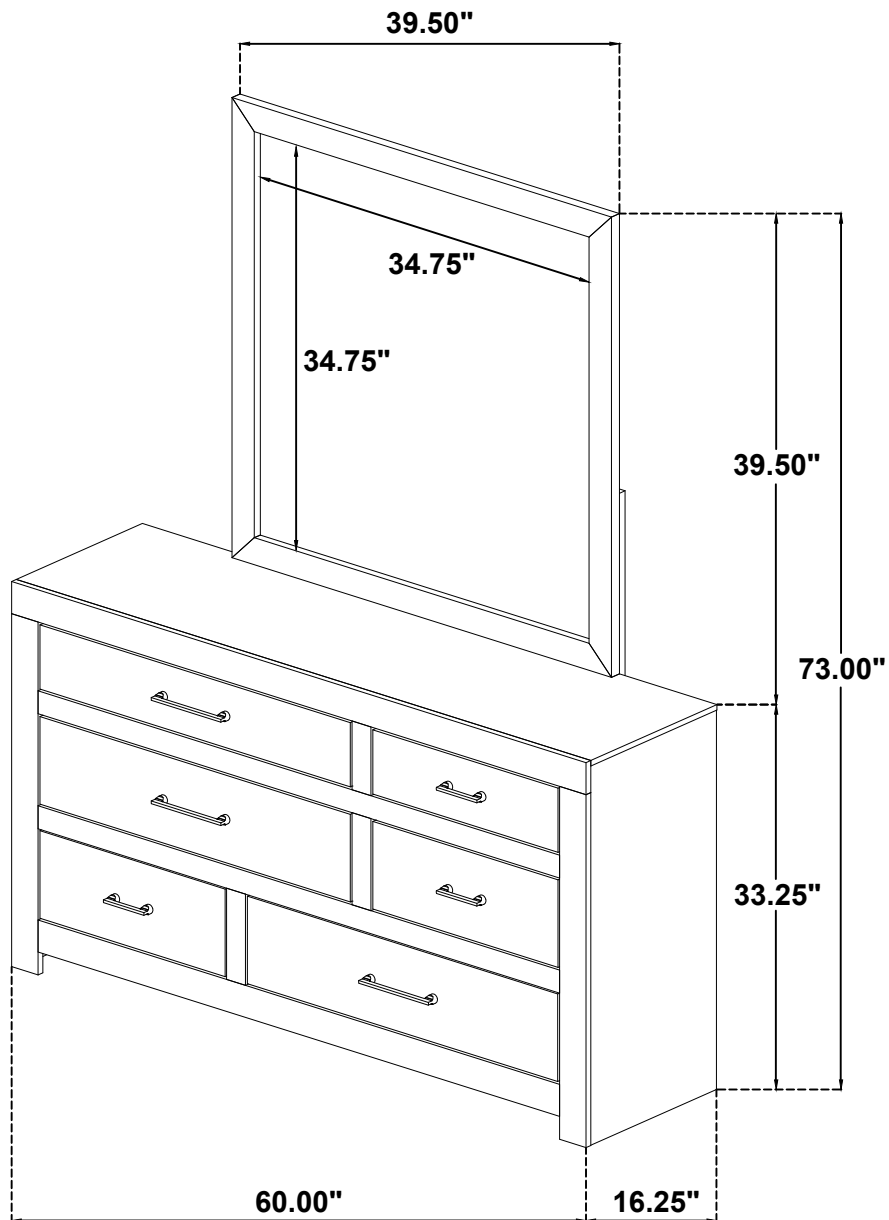

Note : Dimension tolerance  $\pm 5\%$

**ASSEMBLY INSTRUCTIONS**  
**COASTER FINE FURNITURE**

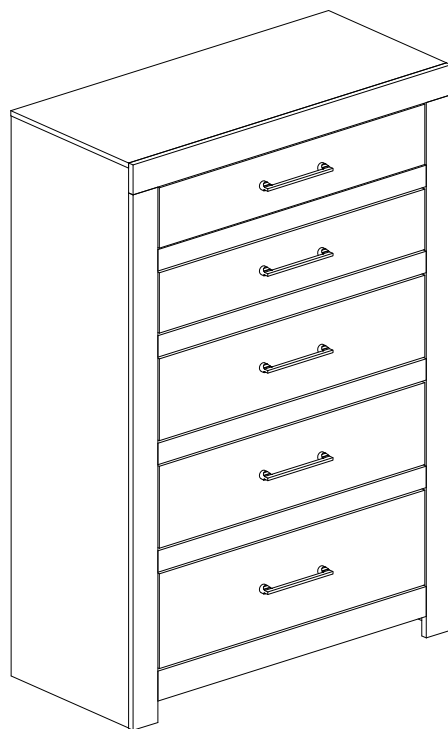

*Fine Furniture for every stage of life*

**222655**  
**Chest**

ITEM: **222655**



## ASSEMBLY INSTRUCTIONS

### ASSEMBLY TIPS:

1. Remove hardware from box and sort by size.
2. Please check to see that all hardware and parts are present prior to start of assembly.
3. Please follow attached instructions in the same sequence as numbered to assure fast & easy assembly.



### WARNING!

1. Don't attempt to repair or modify parts that are broken or defective. Please contact the store immediately.
2. This product is for home use only and not intended for commercial establishments.



ASSEMBLY TIME

10 MINUTES

## PARTS IDENTIFICATION

A CHEST

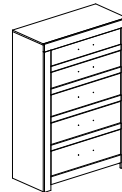

1PC

### NOTE:

Phillips head screw driver is required in the assembly process; however, manufacturer does not provided this item.

ITEM: **222655**



## ASSEMBLY INSTRUCTIONS

### STEP 1

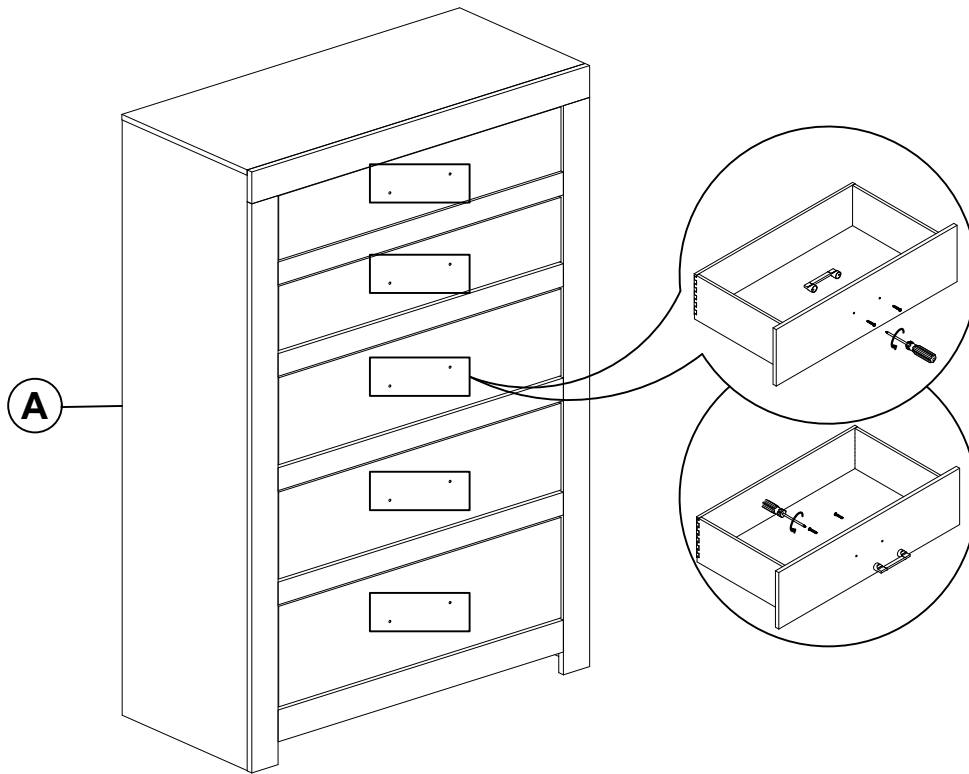

### STEP 2 **COMPLETE**

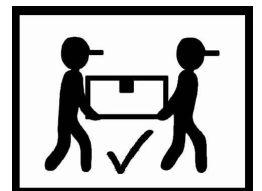
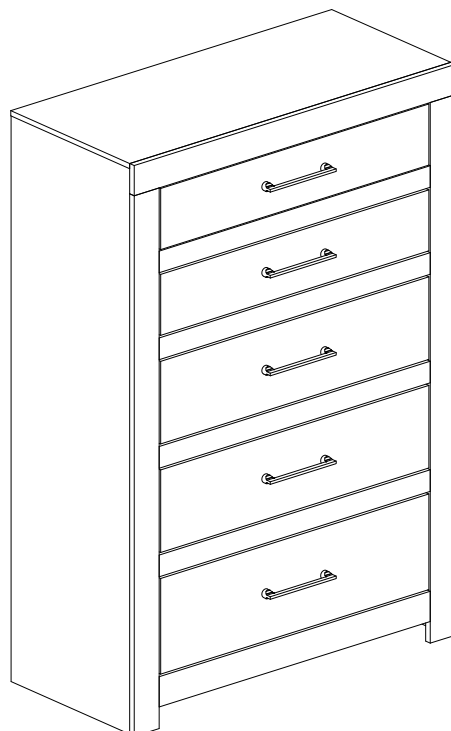

## ANTI-TIPPING INSTALLMENT INSTRUCTIONS FURNITURE TIPPING RESTRAINT

### WARNING

Injury may result from tipping furniture.

This restraint may protect against tipping furniture.

Do not allow children to climb on furniture.

This restraint is not a substitute for proper adult supervision.

Failure to detach this restraint before moving the furniture may result in injury and damage.

1. Attach one of the mounting brackets securely to the back edge of the unit, using the short screw.
2. determine where the unit is to be placed, and mark the location on the wall for the other mounting bracket. The bracket on the wall needs to be approximately 2" below the bracket mounted to the edge of the unit.
3. Drill a hole in the wall. Insert the plastic wall anchor into the hole and if necessary, use a small block of wood and hammer to tap it in so that it's flush with the wall.
4. Attach the bracket over the plastic wall anchor using the long screw.
5. Place the unit against the wall, both brackets need to be placing each other.
6. Lace an end of the restraint strap through the hole in each bracket. Bring both ends together and rotate the thumb nut onto the threaded end until tight.
7. Ensure that the restraint strap is securely laced and locked.

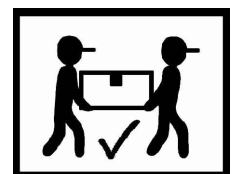
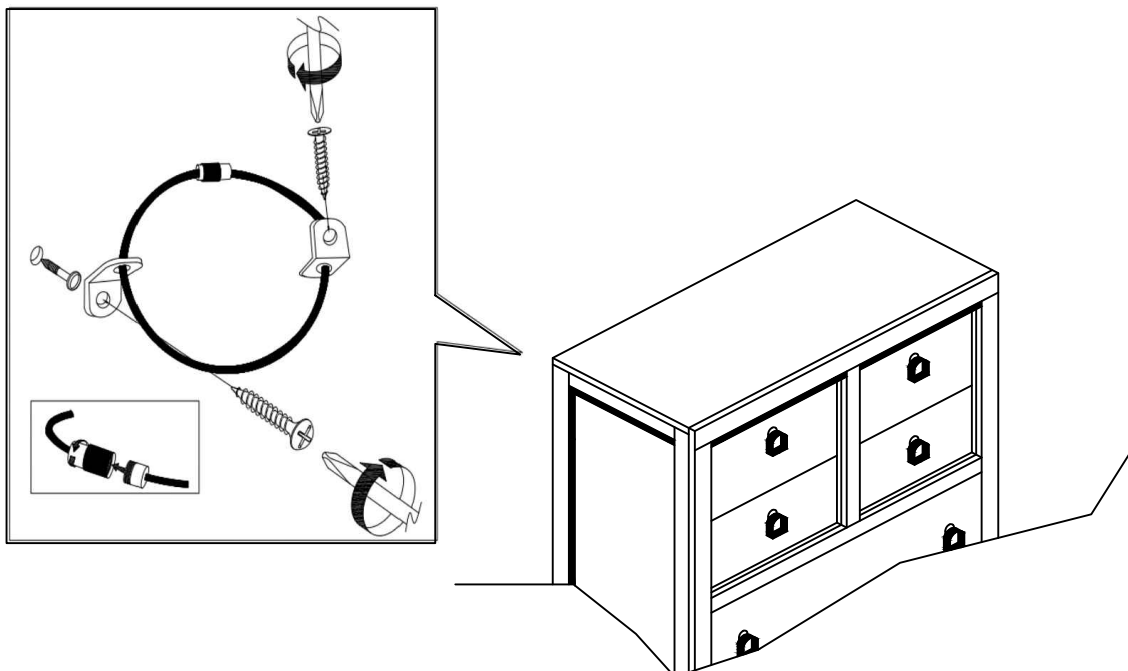

ITEM: **222655**



Inner Size of Drawer A : 28.00"W X 11.75"D X 4.00"H X 0.50"T  
Inner Size of Drawer B : 28.00"W X 11.75"D X 6.00"H X 0.50"T

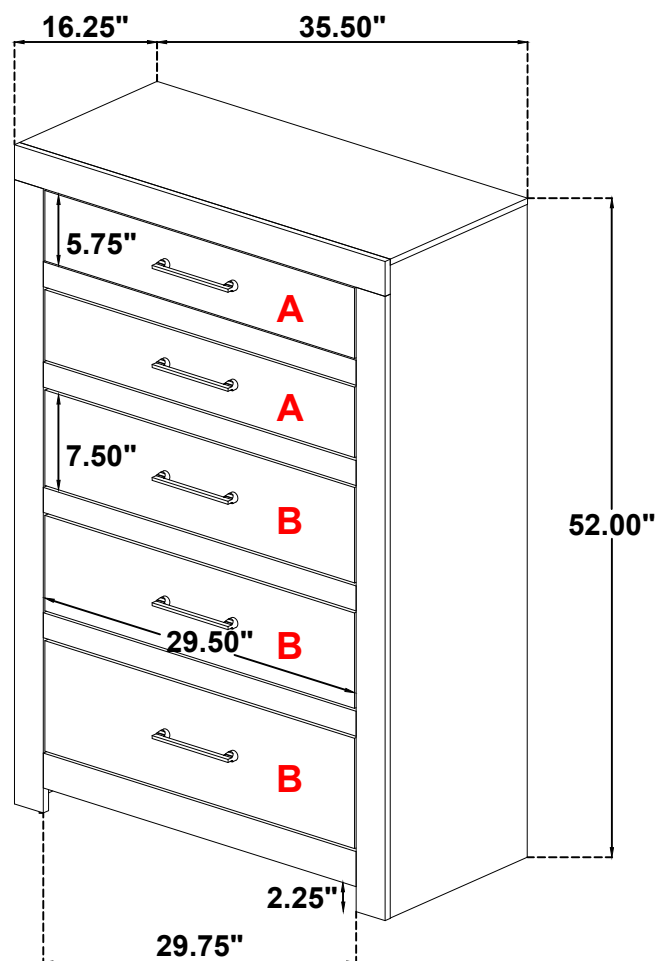

Note : Dimension tolerance  $\pm 5\%$