

*ASSEMBLY INSTRUCTIONS*  
*COASTER FINE FURNITURE*



*Fine Furniture for every stage of life*

**222801KE(B1-B3)**  
**Eastern King Bed**

# ITEM: 222801KE(B1-B3)



## ASSEMBLY INSTRUCTIONS

### ASSEMBLY TIPS:

1. Remove hardware from box and sort by size.
2. Please check to see that all hardware and parts are present prior to start of assembly.
3. Please follow attached instructions in the same sequence as numbered to assure fast & easy assembly.



### WARNING!

1. Don't attempt to repair or modify parts that are broken or defective. Please contact the store immediately.
2. This product is for home use only and not intended for commercial establishments.

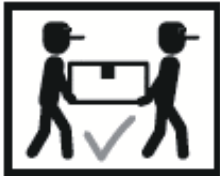

ASSEMBLY TIME

30 MINUTES

## PART IDENTIFICATION

### B1 (BOX 1)

A	HEADBOARD PANEL		1PC
B	LEFT HEADBOARD LEG		1PC
C	RIGHT HEADBOARD LEG		1PC
D	HEADBOARD BOTTOM RAIL		1PC
E	CONCEAL PANEL		4PCS

### B2 (BOX 2)

F	FOOTBOARD		1PC
---	-----------	--	-----

### B3 (BOX 3)

G	LEFT BED RAIL		1PC
H	RIGHT BED RAIL		1PC
I	ROLL SLAT (10 PCS)		1SET
J	CENTER RAIL		1PC
K	CENTER RAIL SUPPORT WITH LEVELER		3PCS
HB	222801KE(B1) FROM BOX 1 HEADBOARD COMPLETE		1PC
F	222801KE(B2) FROM BOX 2 FOOTBOARD		1PC

# ITEM: 222801KE(B1-B3)

## ASSEMBLY INSTRUCTIONS

### ASSEMBLY TIPS:

1. Remove hardware from box and sort by size.
2. Please check to see that all hardware and parts are present prior to start of assembly.
3. Please follow attached instructions in the same sequence as numbered to assure fast & easy assembly.







### WARNING!



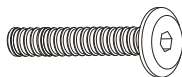





1. Don't attempt to repair or modify parts that are broken or defective. Please contact the store immediately.
2. This product is for home use only and not intended for commercial establishments.

## HARDWARE IDENTIFICATION

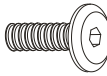
### Z-B1 (BOX 1) - HARDWARE PACK IS LOCATED IN 222801KE(B1)

1	<b>LONG BOLT</b> (5/16" x 50mm - BLK)		8PCS
2	<b>LOCK WASHER</b> (1.6 x 14mm - BLK)		8PCS
3	<b>FLAT WASHER</b> (2 x 19mm - BLK)		8PCS
4	<b>ALLEN WRENCH</b> (M5 x 75mm - BLK)		1PC
5	<b>WOOD DOWEL</b> (10 x 40mm - BRW)		8PCS

### Z-B3 (BOX 3) - HARDWARE PACK IS LOCATED IN 222801KE(B3)

2	<b>LOCK WASHER</b> (1.6 x 14mm - BLK)		4PCS
3	<b>FLAT WASHER</b> (2 x 19mm - BLK)		4PCS
6	<b>SHORT BOLT</b> (5/16" x 19mm - BLK)		4PCS
7	<b>FLAT HEAD SCREW</b> (8 x 32mm - BLK)		8PCS
8	<b>THREADED BOLT</b> (5/16" x 80mm - WHT)		8PCS
9	<b>HEX NUT</b> (5/16" x 13mm - WHT)		8PCS
10	<b>HALF ROUND NUT</b> (22 x 17 x 10mm - WHT)		8PCS
11	<b>WRENCH</b> (13mm - WHT)		1PC

### NOTE :

Philips head screw driver is required in the assembly process; however, manufacturer does not provide this item.

# ITEM: 222801KE(B1-B3)

## ASSEMBLY INSTRUCTIONS

### STEP 1

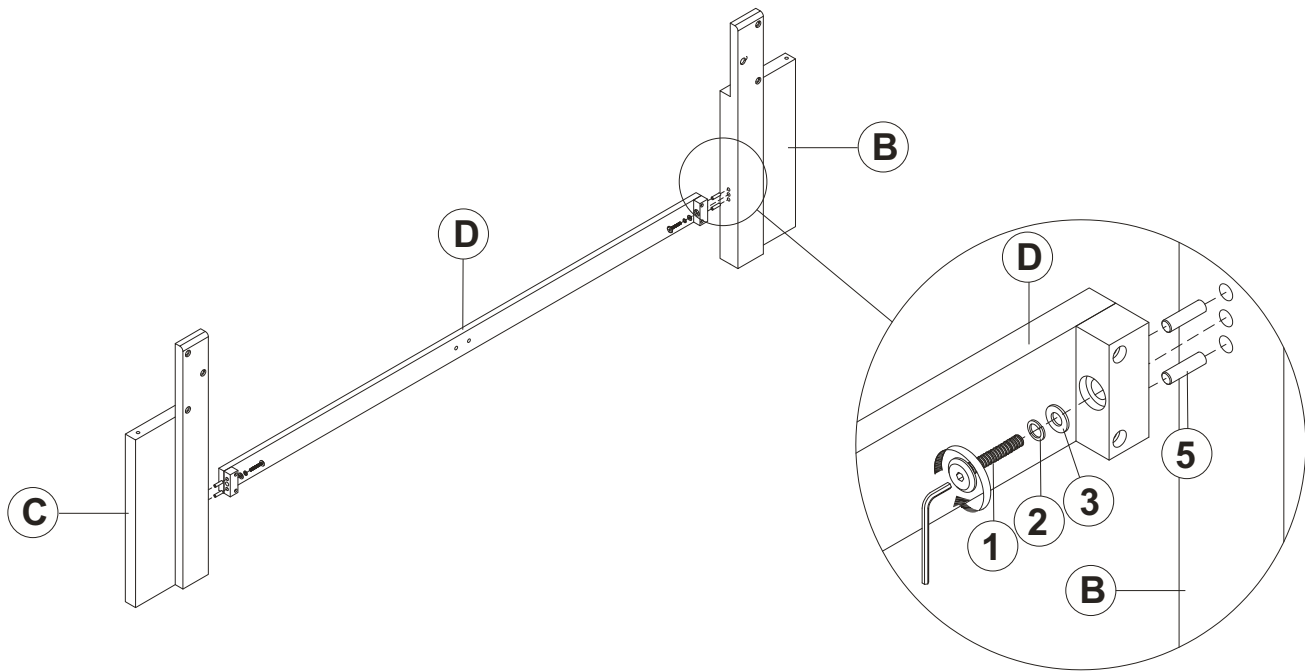

### STEP 2

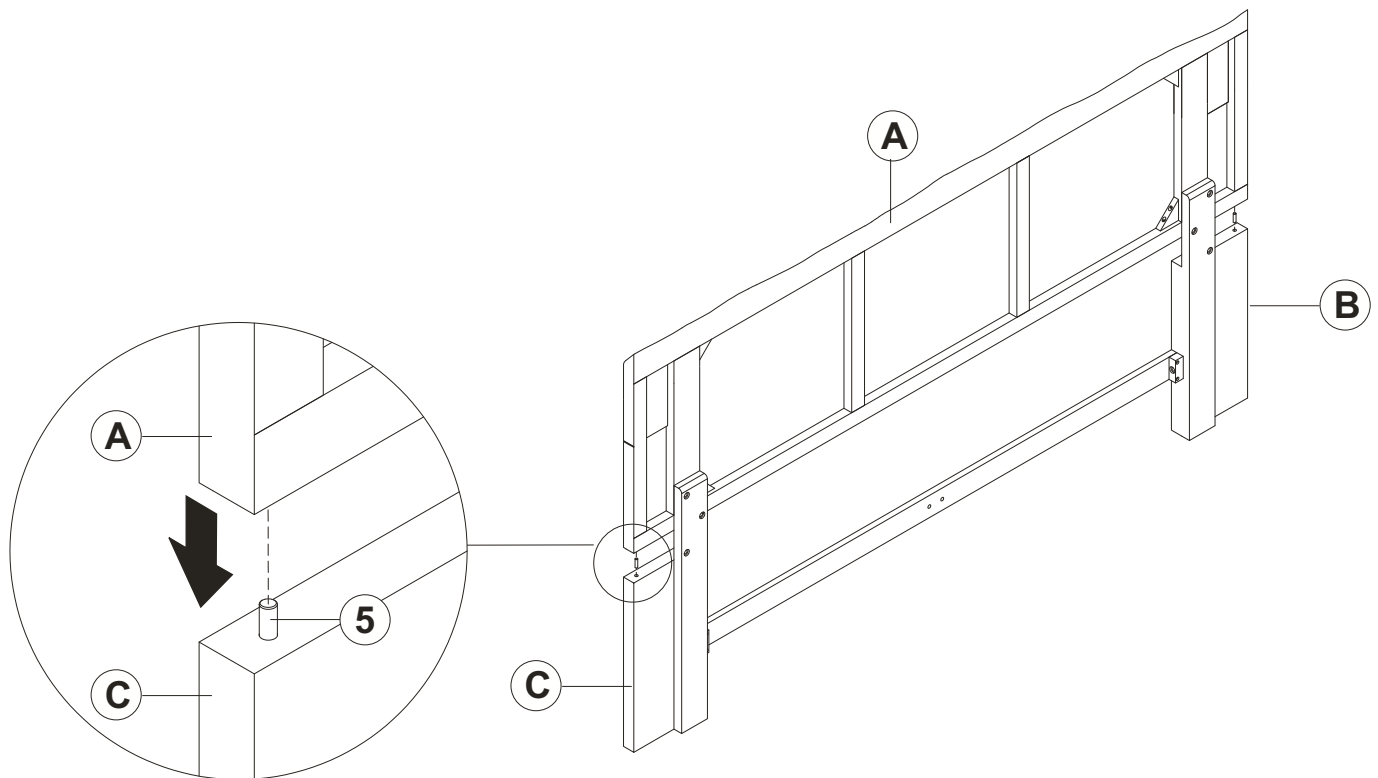

# ITEM: 222801KE(B1-B3)

## ASSEMBLY INSTRUCTIONS



### STEP 3

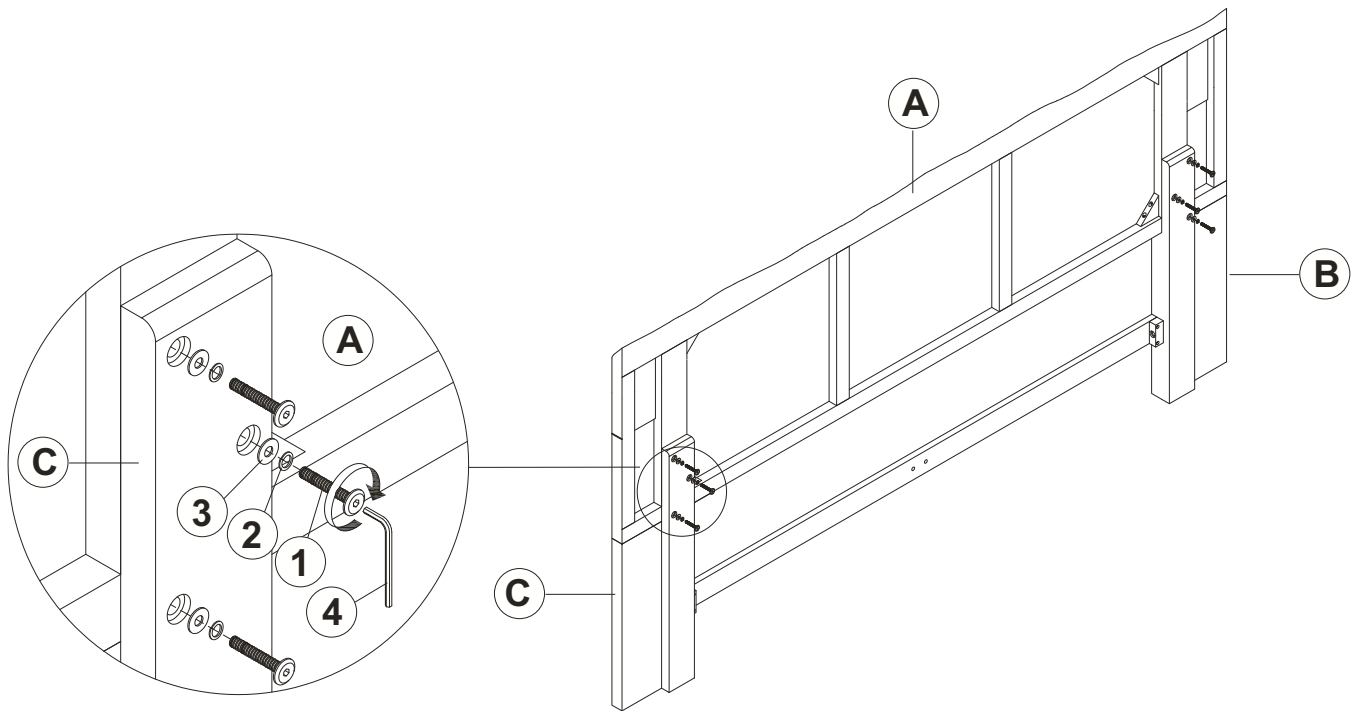

### STEP 4

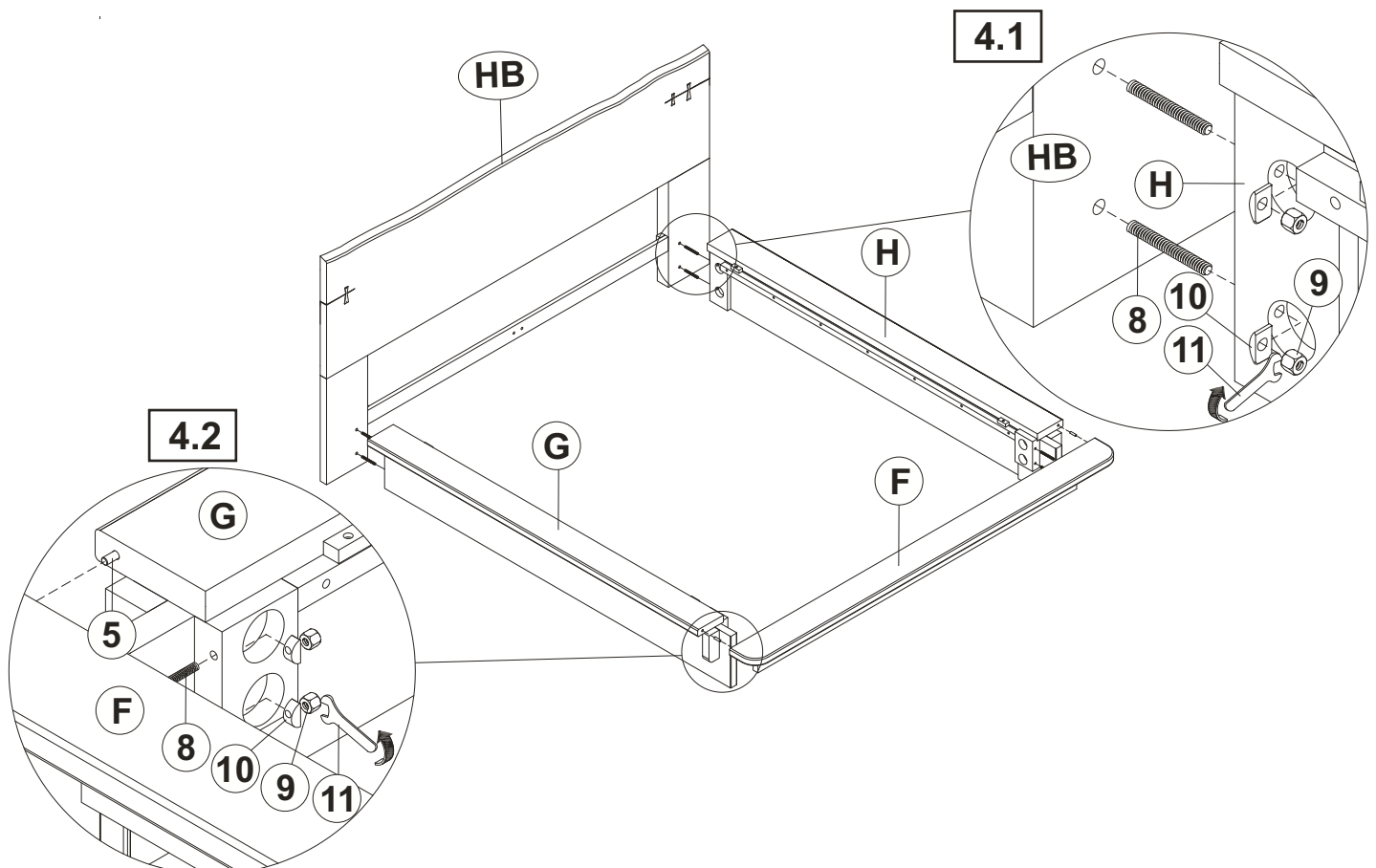

# ITEM: 222801KE(B1-B3)

## ASSEMBLY INSTRUCTIONS

### STEP 5

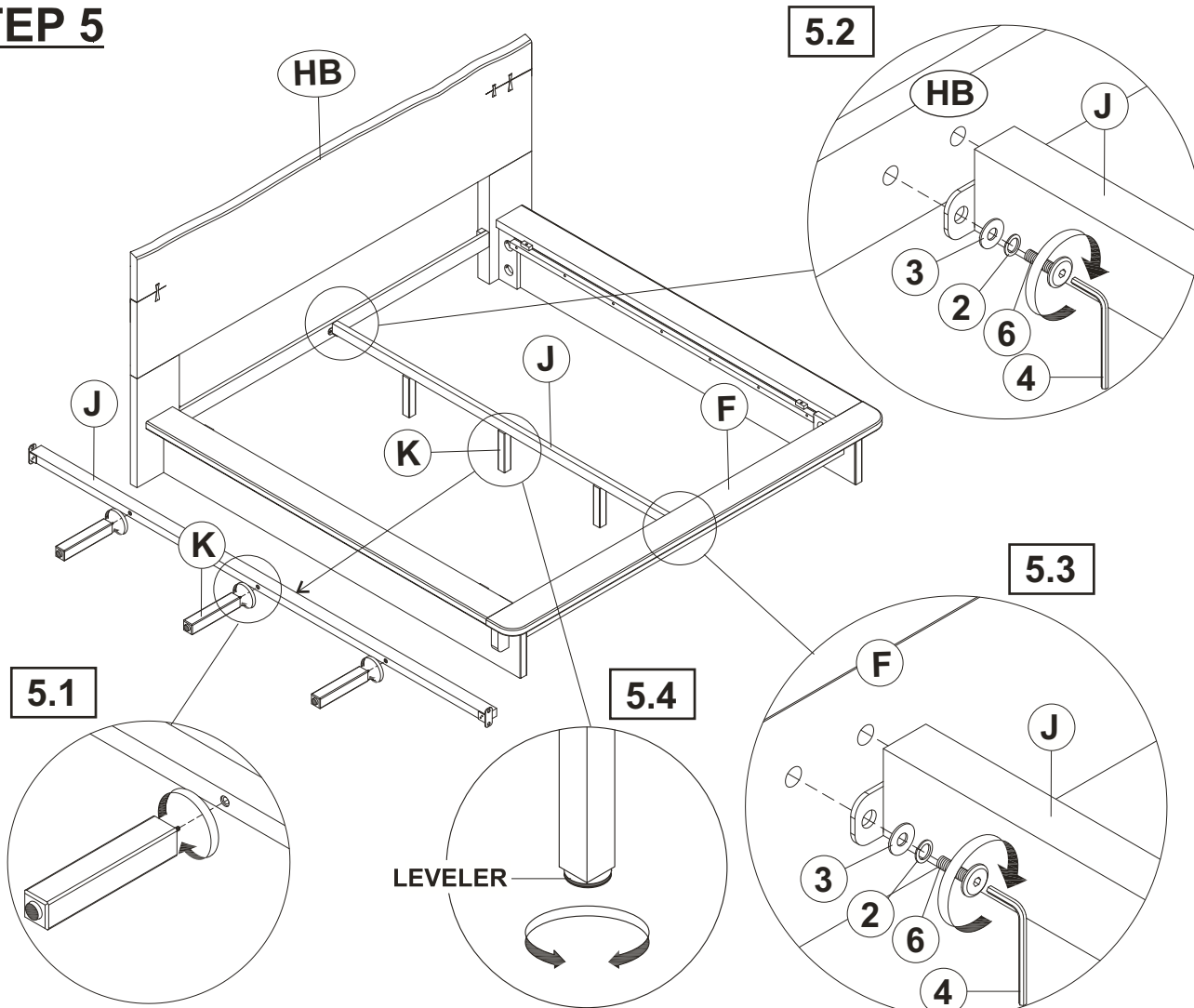

### STEP 6

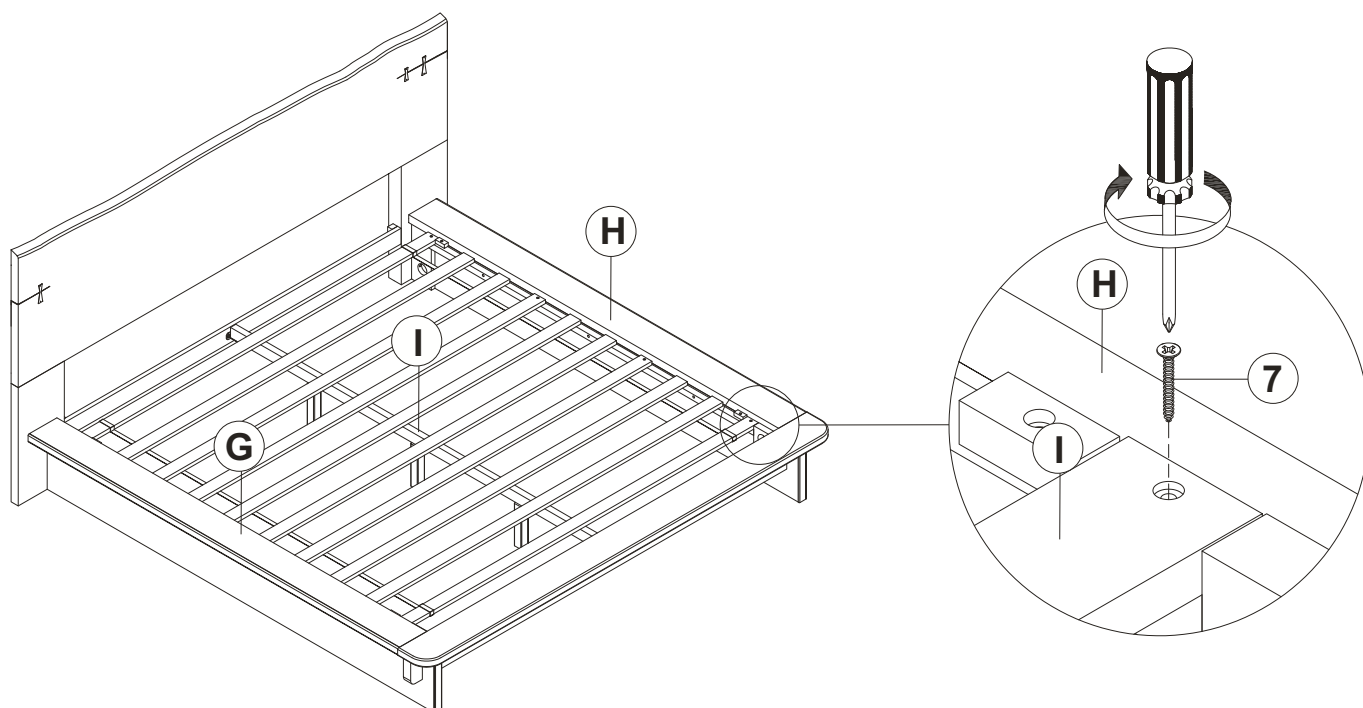

ITEM: **222801KE(B1-B3)**  
**ASSEMBLY INSTRUCTIONS**

**STEP 7**

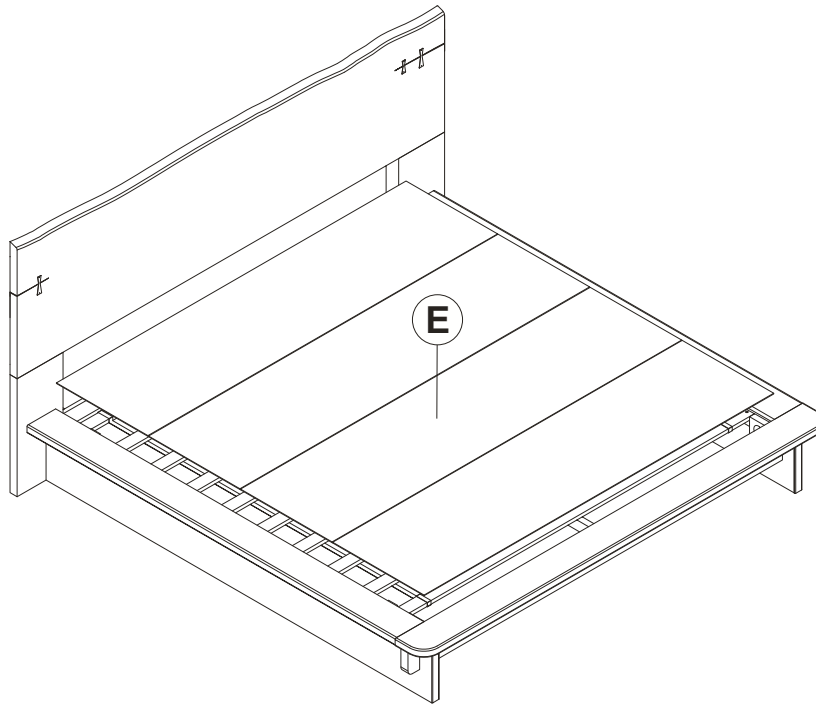

**STEP 8**  
**COMPLETE**

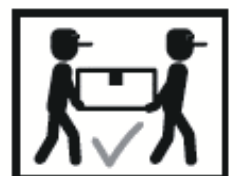
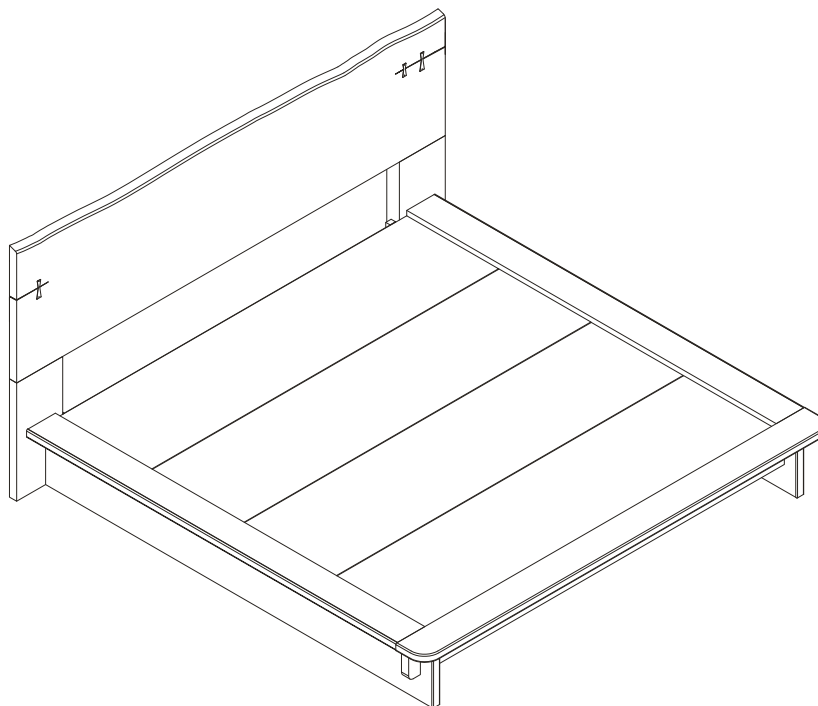

ITEM: **222801KE(B1-B3)**



Inner Size : 77.00"W x 81.00"D

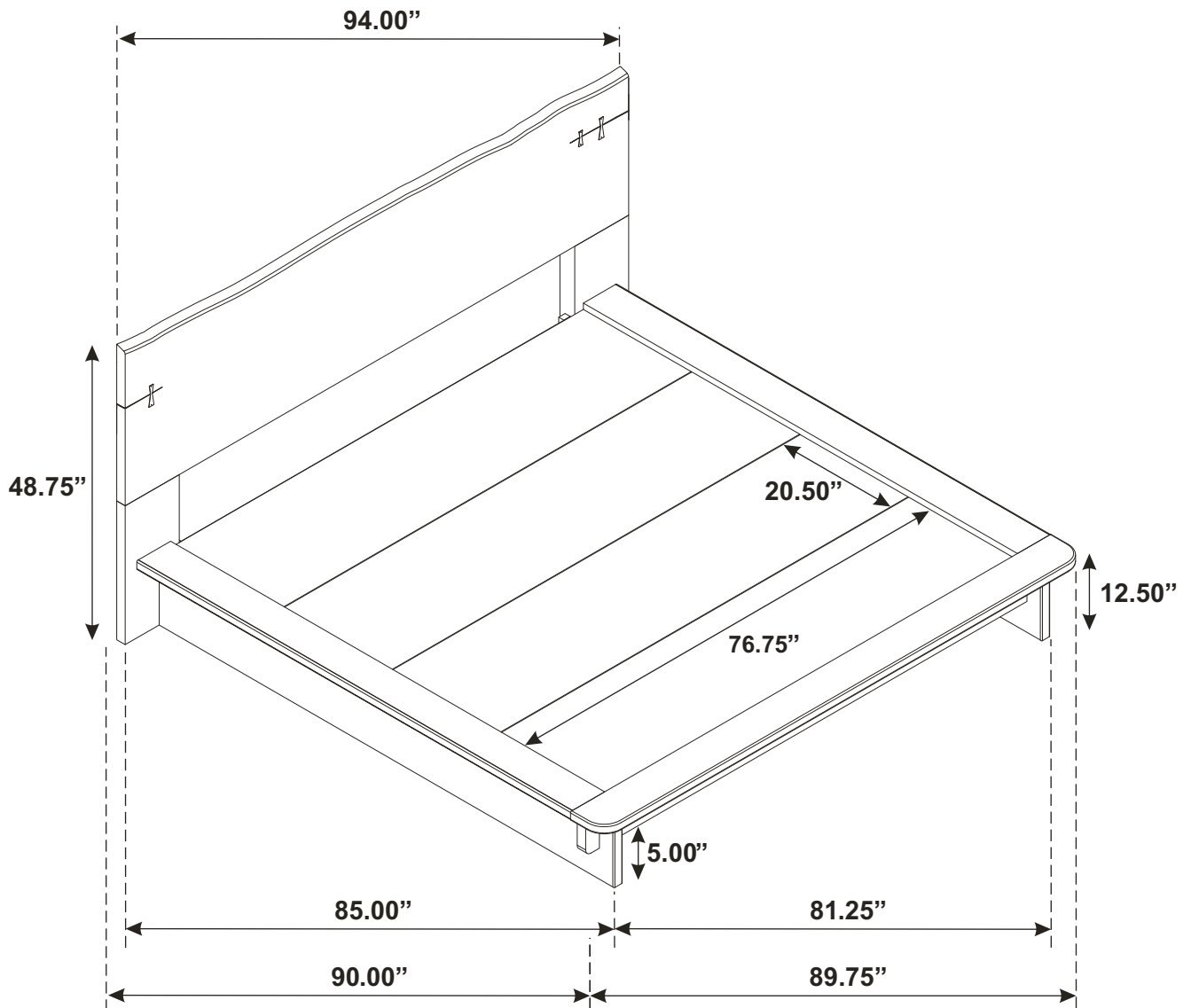

Note: Dimension tolerance  $\pm 5\%$

**ASSEMBLY INSTRUCTIONS**  
**COASTER FINE FURNITURE**



*Fine Furniture for every stage of life*

**222802**  
**Nightstand**

# ITEM: 222802

## ASSEMBLY INSTRUCTIONS

### ASSEMBLY TIPS:

1. Remove hardware from box and sort by size.
2. Please check to see that all hardware and parts are present prior to start of assembly.
3. Please follow attached instructions in the same sequence as numbered to assure fast & easy assembly.



### WARNING!

1. Don't attempt to repair or modify parts that are broken or defective. Please contact the store immediately.
2. This product is for home use only and not intended for commercial establishments.



ASSEMBLY TIME

10 MINUTES

## PART IDENTIFICATION

A NIGHTSTAND

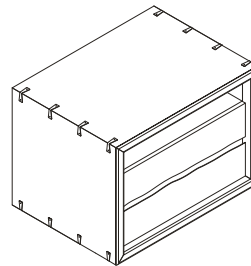

1PC

B FRONT FRAME RAIL

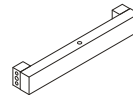

1PC

C LEFT SIDE FRAME

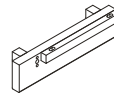

1PC

D RIGHT SIDE FRAME

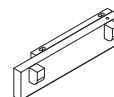

1PC

## HARDWARE IDENTIFICATION

1 BOLT  
(5/16 x 60mm - BLK)

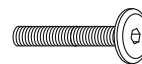

7PCS

2 LOCK WASHER  
(1.6 x 14mm - BLK)



7PCS

3 FLAT WASHER  
(2 x 18mm - BLK)



7PCS

4 ALLEN WRENCH  
(M5 x 75mm - BLK)



1PC

5 WOOD DOWEL  
(10 x 40mm)



6PCS

ITEM: **222802**

**ASSEMBLY INSTRUCTIONS**

**STEP 1**

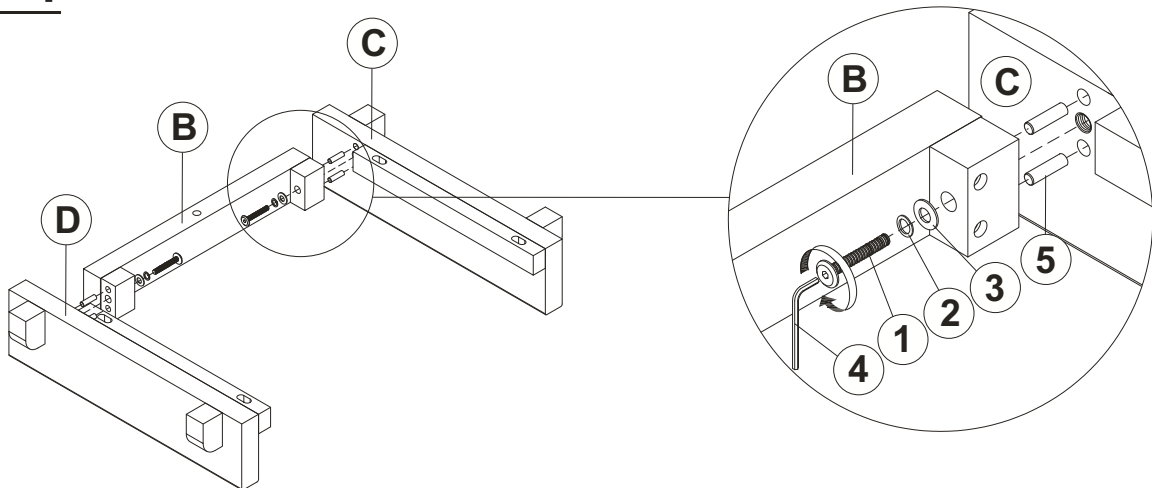

**STEP 2**

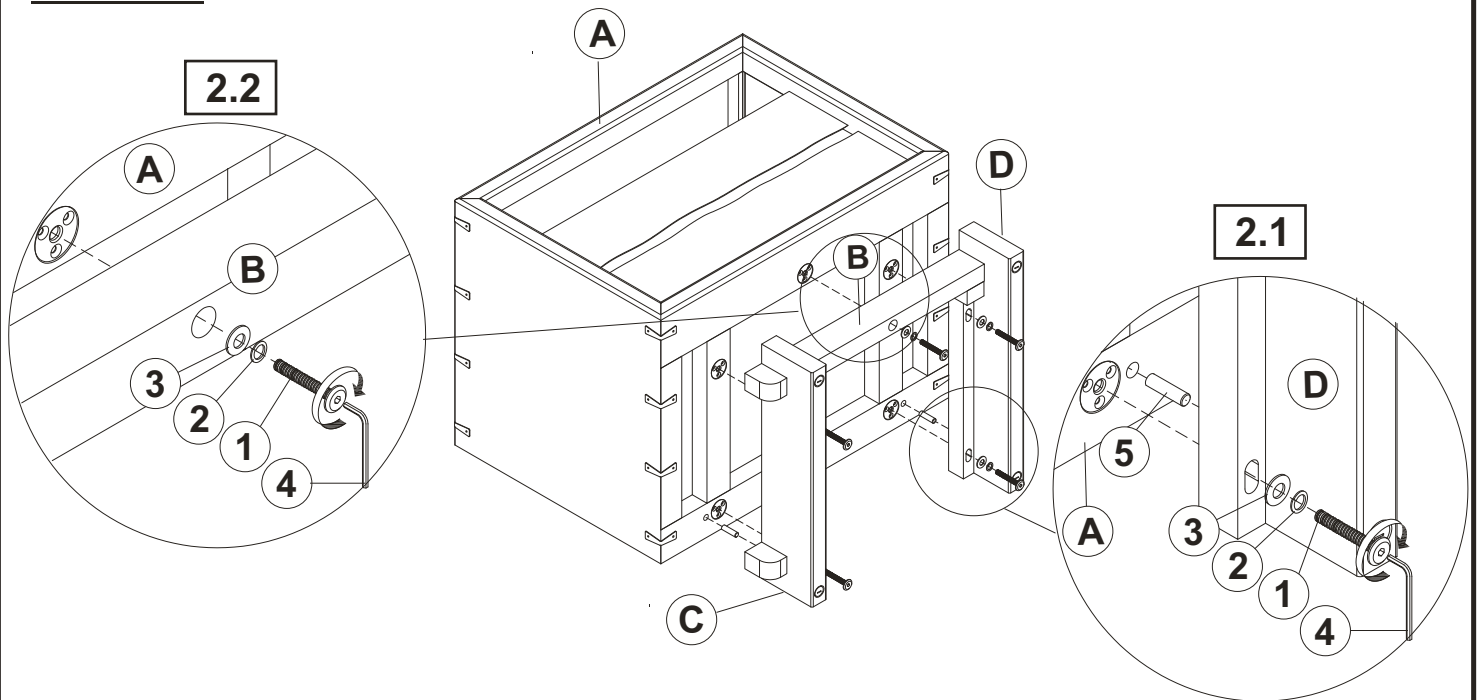

**STEP 3**  
**COMPLETE**

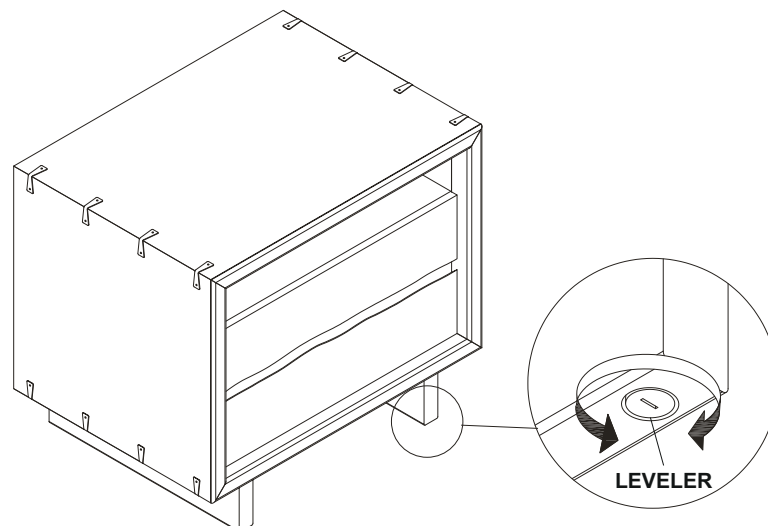

ITEM: **222802**

**Inner Size of Drawer A : 22.00"W x 13.75"D x 2.50"H x 0.50"T**  
**Inner Size of Drawer B : 22.00"W x 13.75"D x 3.25"H x 0.50"T**

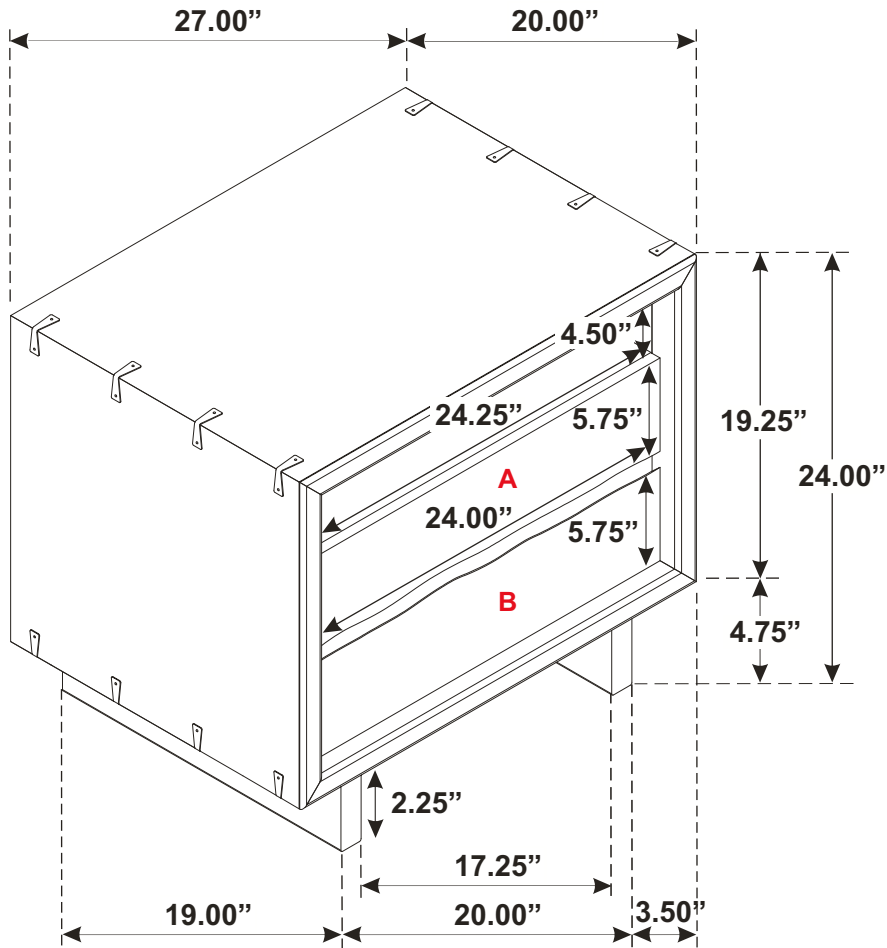

**Note: Dimension tolerance  $\pm 5\%$**

*ASSEMBLY INSTRUCTIONS  
COASTER FINE FURNITURE*



*Fine Furniture for every stage of life*

**222803**  
**Dresser**

ITEM: **222803**

## ASSEMBLY INSTRUCTIONS

### ASSEMBLY TIPS:

1. Remove hardware from box and sort by size.
2. Please check to see that all hardware and parts are present prior to start of assembly.
3. Please follow attached instructions in the same sequence as numbered to assure fast & easy assembly.



### WARNING!





1. Don't attempt to repair or modify parts that are broken or defective. Please contact the store immediately.
2. This product is for home use only and not intended for commercial establishments.





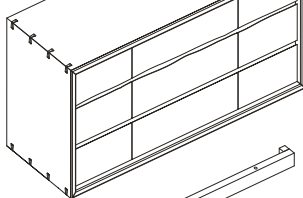
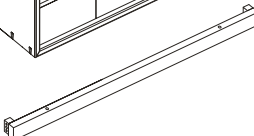

ASSEMBLY TIME

10 MINUTES

## PART IDENTIFICATION

A	DRESSER		1PC
B	FRONT FRAME RAIL		1PC
C	LEFT SIDE FRAME		1PC
D	RIGHT SIDE FRAME		1PC
E	CENTER SUPPORT LEG WITH LEVELER		1PC

## HARDWARE IDENTIFICATION

1	BOLT (5/16 x 60mm - BLK)		8PCS
2	LOCK WASHER (1.6 x 14mm - BLK)		8PCS
3	FLAT WASHER (2 x 18mm - BLK)		8PCS
4	ALLEN WRENCH (M5 x 75mm - BLK)		1PC
5	WOOD DOWEL (10 x 40mm)		6PCS

ITEM: **222803**

**ASSEMBLY INSTRUCTIONS**

**STEP 1**

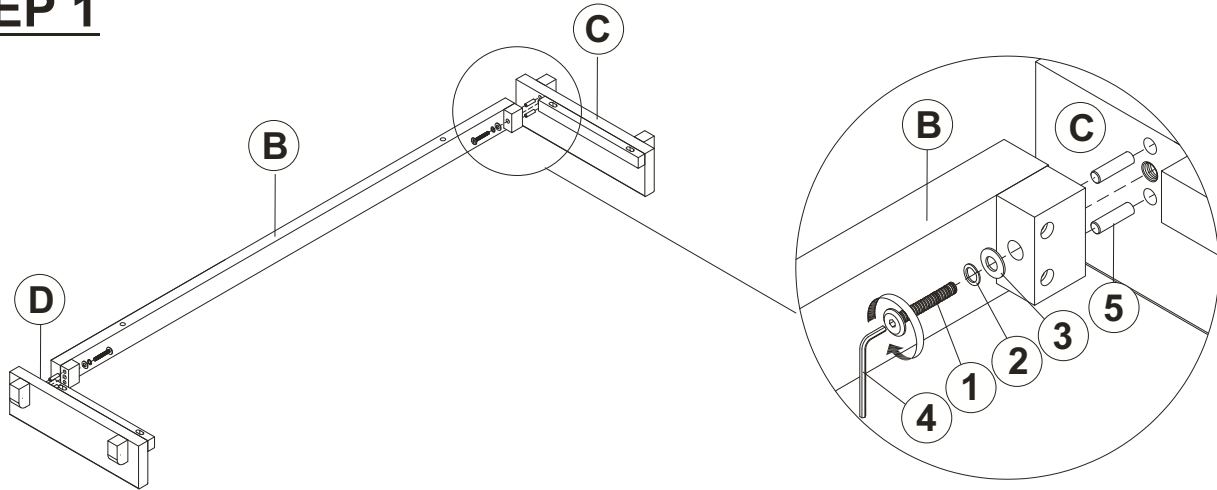

**STEP 2**

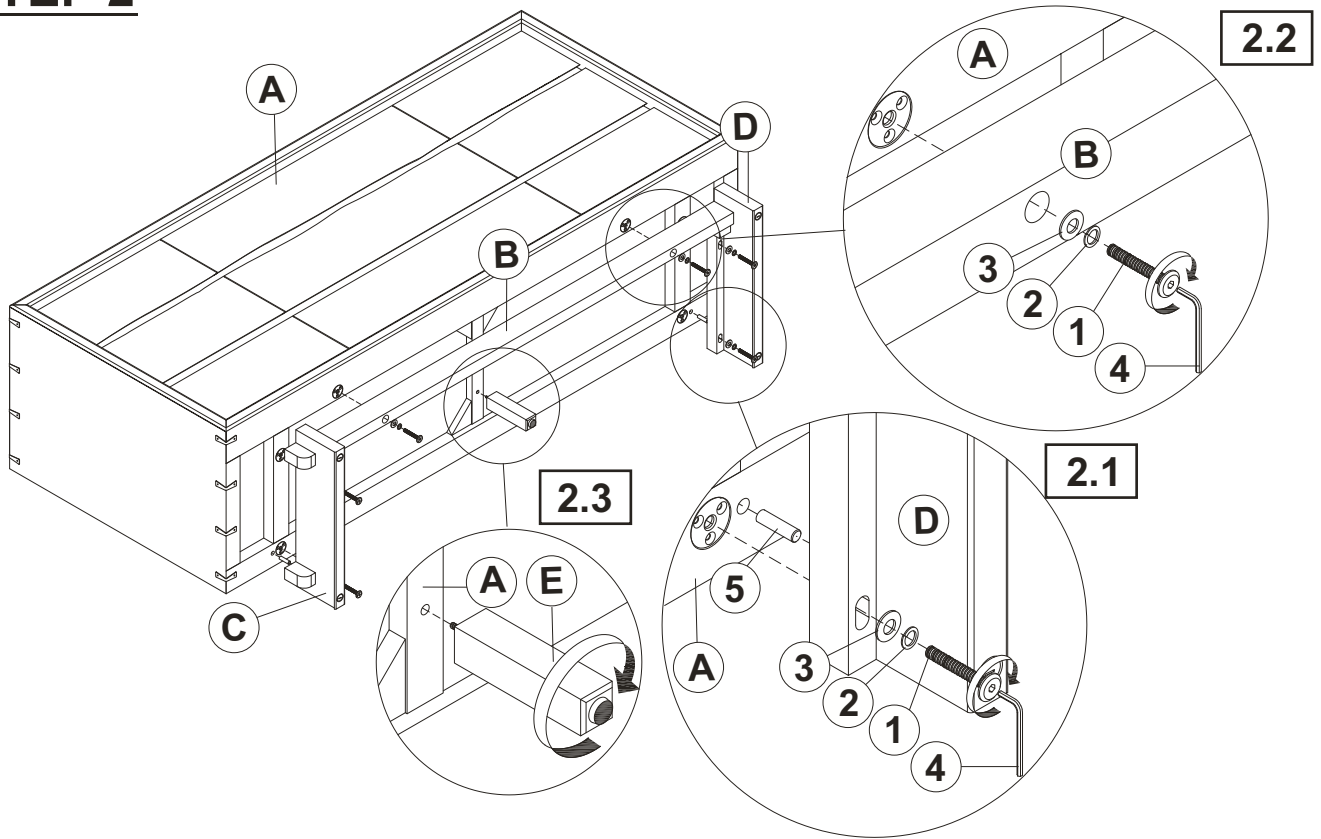

**STEP 3  
COMPLETE**

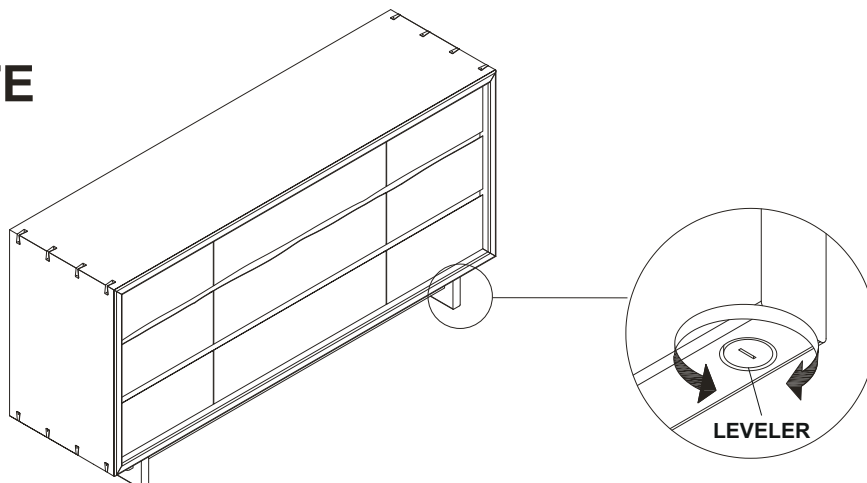

## ANTI-TIPPING INSTALLATION INSTRUCTIONS

### FURNITURE TIPPING RESTRAINT

#### WARNING

Injury may result from tipping furniture.

This restraint may protect against tipping furniture.

Do not allow children to climb on furniture.

This restraint is not a substitute for proper adult supervision.

Failure to detach this restraint before moving the furniture may result in injury and damage.

1. Attach one of the mounting brackets securely to the back edge of the unit, using the short screw.
2. Determine where the unit is to be placed, and mark the location on the wall for the other mounting bracket. The bracket on the wall needs to be approximately 2" below the bracket mounted to the edge of the unit.
3. Drill a hole in the wall. Insert the plastic wall anchor into the hole and if necessary, use a small block of wood and hammer to tap it in so that it's flush with the wall.
4. Attach the bracket over the plastic wall anchor using the long screw.
5. Place the unit against the wall, both brackets need to be facing each other.
6. Lace an end of the restraint strap through the hole in each bracket. Bring both ends together and rotate the thumb nut onto the threaded end until tight.
7. Ensure that the restraint strap is securely laced and locked.

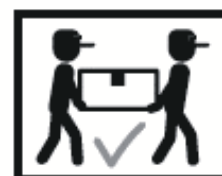
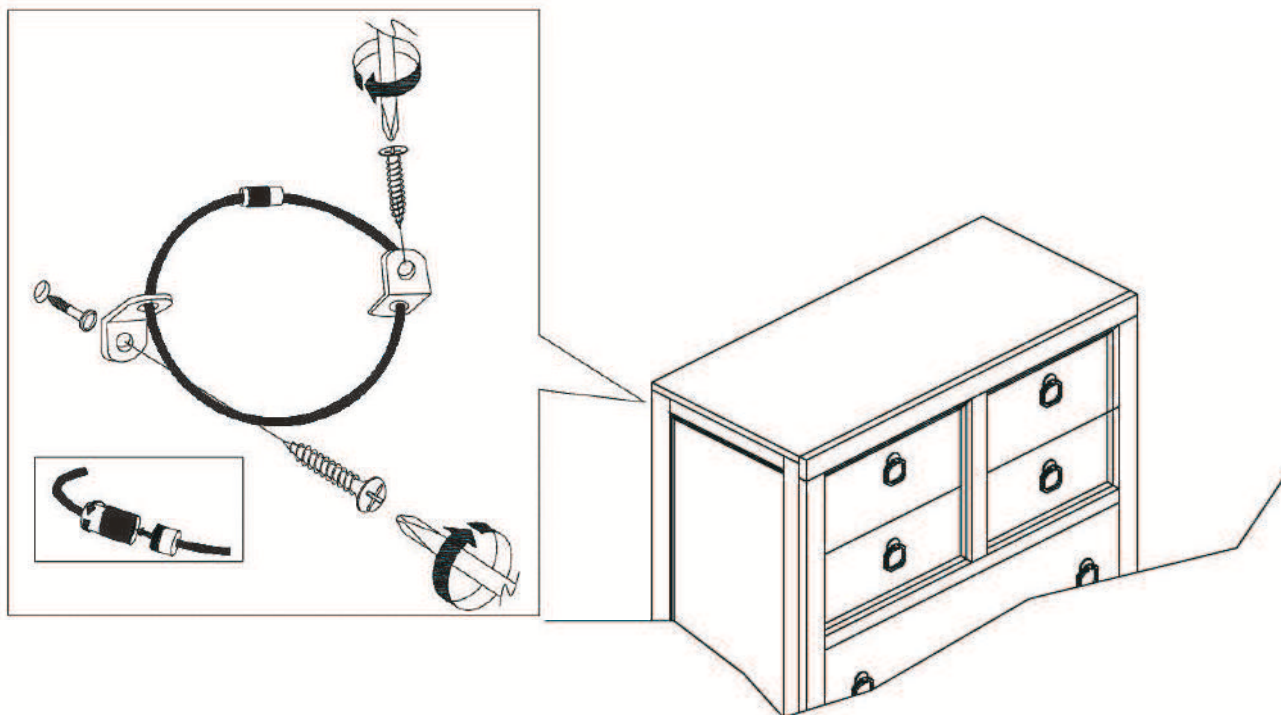

ITEM: **222803**

Inner Size of Drawer A : 15.75"W x 13.75"D x 5.25"H x 0.50"T  
Inner Size of Drawer B : 29.75"W x 13.75"D x 5.25"H x 0.50"T  
Inner Size of Drawer C : 15.75"W x 13.75"D x 5.25"H x 0.50"T  
Inner Size of Drawer D : 15.75"W x 13.75"D x 6.75"H x 0.50"T  
Inner Size of Drawer E : 29.75"W x 13.75"D x 6.75"H x 0.50"T

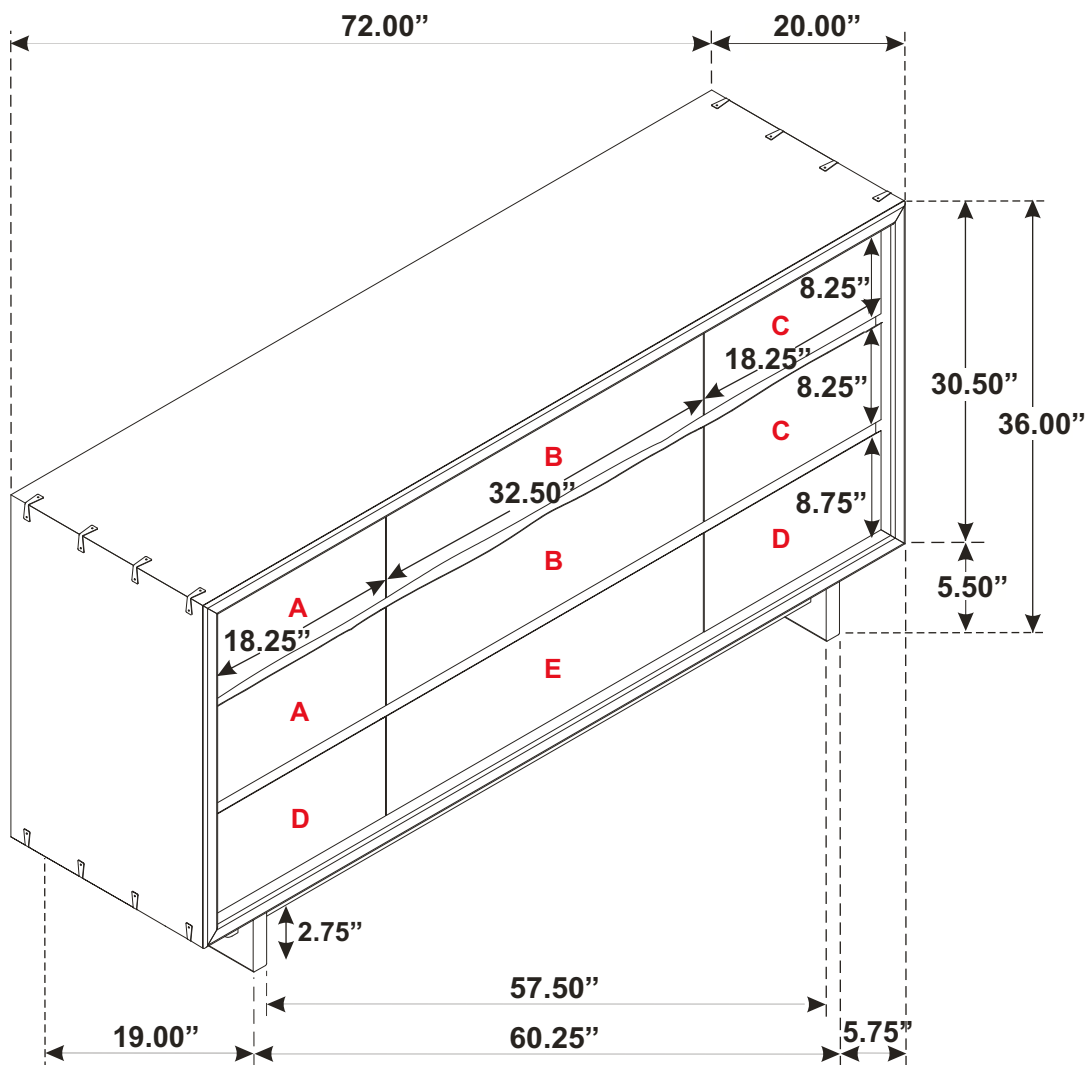

Note: Dimension tolerance  $\pm 5\%$

*ASSEMBLY INSTRUCTIONS*  
*COASTER FINE FURNITURE*



*Fine Furniture for every stage of life*

**222804**  
**Mirror**

ITEM: **222804**



## ASSEMBLY INSTRUCTIONS

### ASSEMBLY TIPS:

1. Remove hardware from box and sort by size.
2. Please check to see that all hardware and parts are present prior to start of assembly.
3. Please follow attached instructions in the same sequence as numbered to assure fast & easy assembly.



### WARNING!

1. Don't attempt to repair or modify parts that are broken or defective. Please contact the store immediately.
2. This product is for home use only and not intended for commercial establishments.



ASSEMBLY TIME

10 MINUTES

## PART IDENTIFICATION

A **DRESSER**  
\*FROM BOX ITEM 222803\*

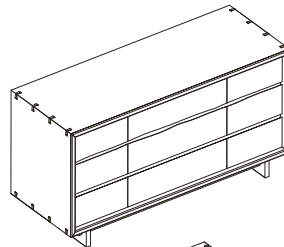

1PC

B **MIRROR**

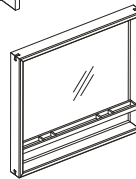

1PC

C **MIRROR SUPPORT**  
(PACKED WITH MIRROR)

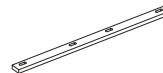

2PCS

## HARDWARE IDENTIFICATION

1 **BOLT**  
(5/16" x 45mm - BLK)

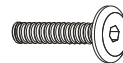

8PCS

2 **LOCK WASHER**  
(1.6 x 14mm - BLK)



8PCS

3 **FLAT WASHER**  
(2 x 19mm - BLK)



8PCS

4 **ALLEN WRENCH**  
(M5 x 75mm - BLK)



1PC

ITEM: **222804**

**ASSEMBLY INSTRUCTIONS**



**STEP 1**

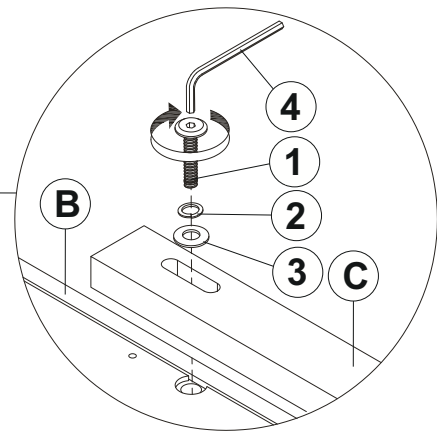
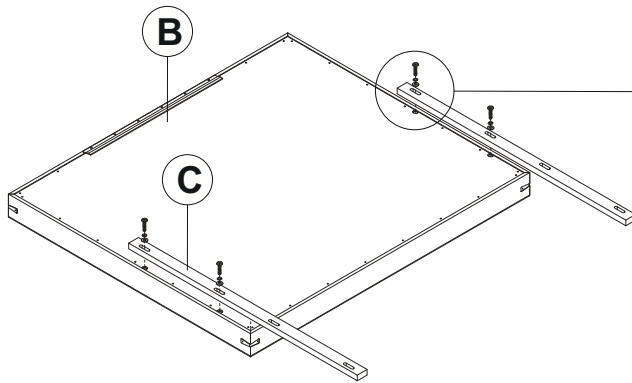

**STEP 2**

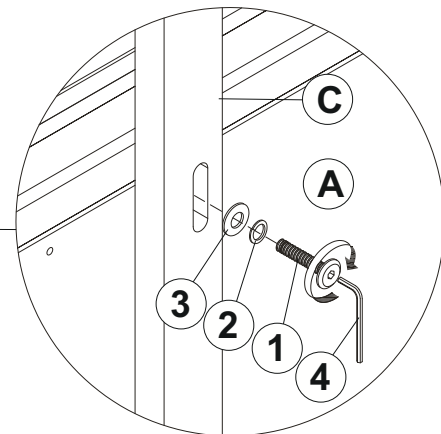
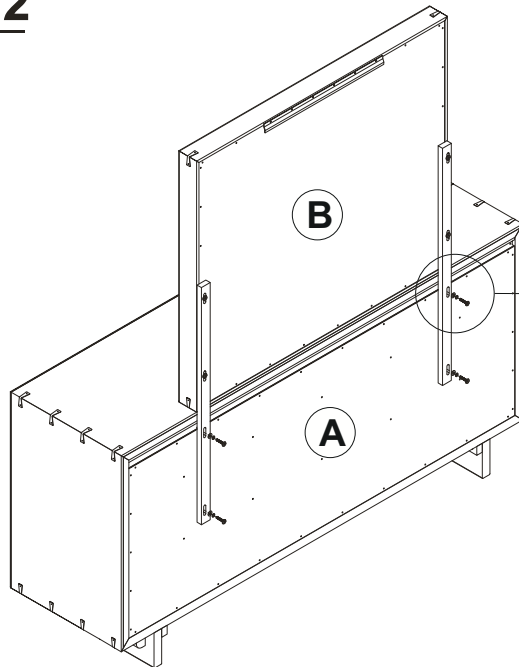

**STEP 3**  
**COMPLETE**

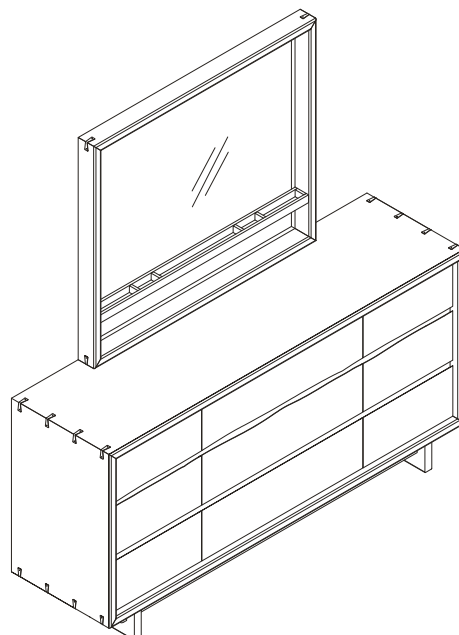

# ITEM: 222804



## ASSEMBLY INSTRUCTIONS

### ASSEMBLY TIPS:

1. Remove hardware from box and sort by size.
2. Please check to see that all hardware and parts are present prior to start of assembly.
3. Please follow attached instructions in the same sequence as numbered to assure fast & easy assembly.



### WARNING!

1. Don't attempt to repair or modify parts that are broken or defective. Please contact the store immediately.
2. This product is for home use only and not intended for commercial establishments.



ASSEMBLY TIME

15 MINUTES

## PART IDENTIFICATION

B MIRROR

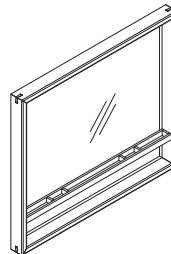

1PC

D HANGING BAR  
(PACKED WITH MIRROR)

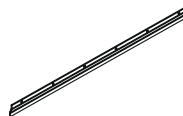

1PC

## HARDWARE IDENTIFICATION

6 PAN HEAD SCREW  
(8 x 2" - BLK)



6PCS

7 PLASTIC ANCHOR  
(S8 - GREY)



6PCS

ITEM: **222804**

**ASSEMBLY INSTRUCTIONS**

**STEP 1  
FOR HANGING MIRROR**

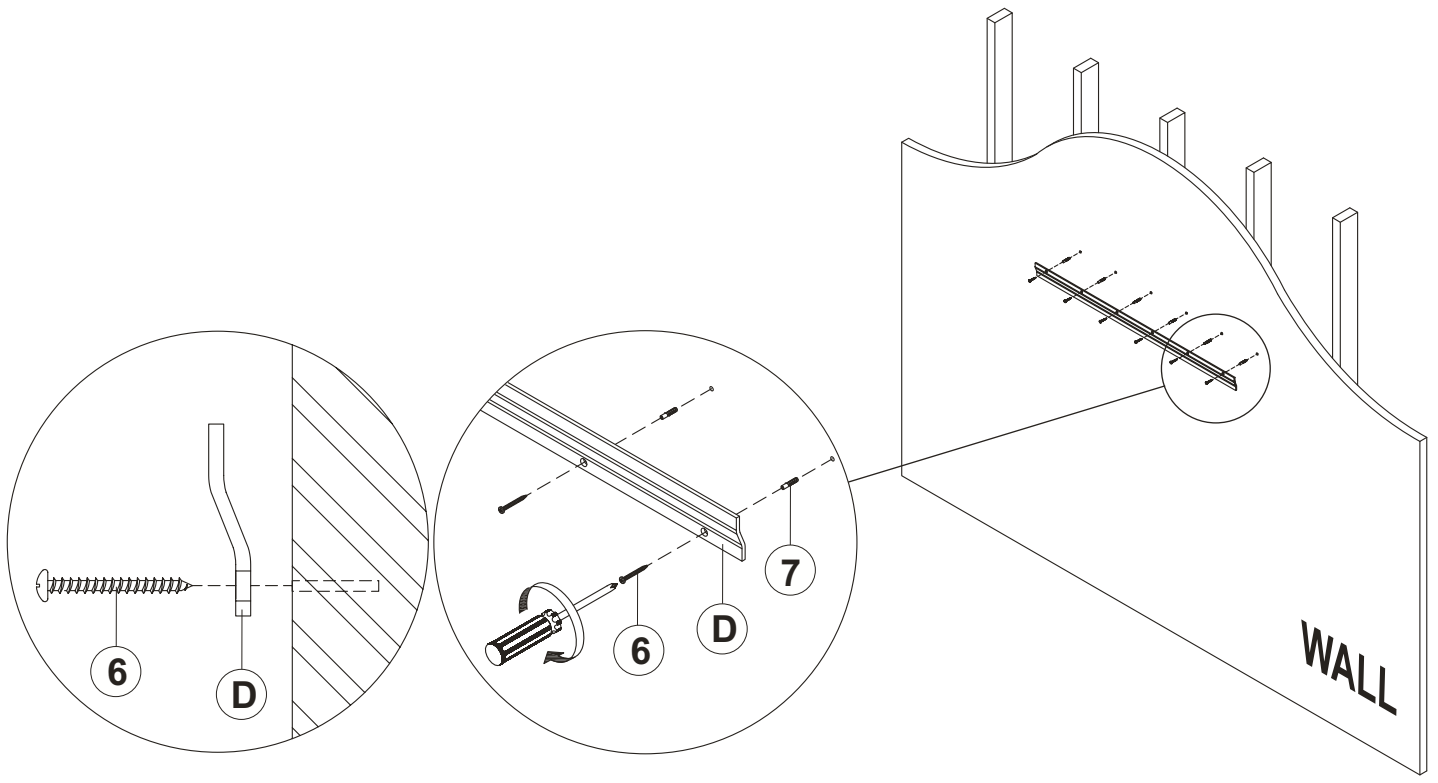

**STEP 2  
FOR HANGING MIRROR  
COMPLETE**

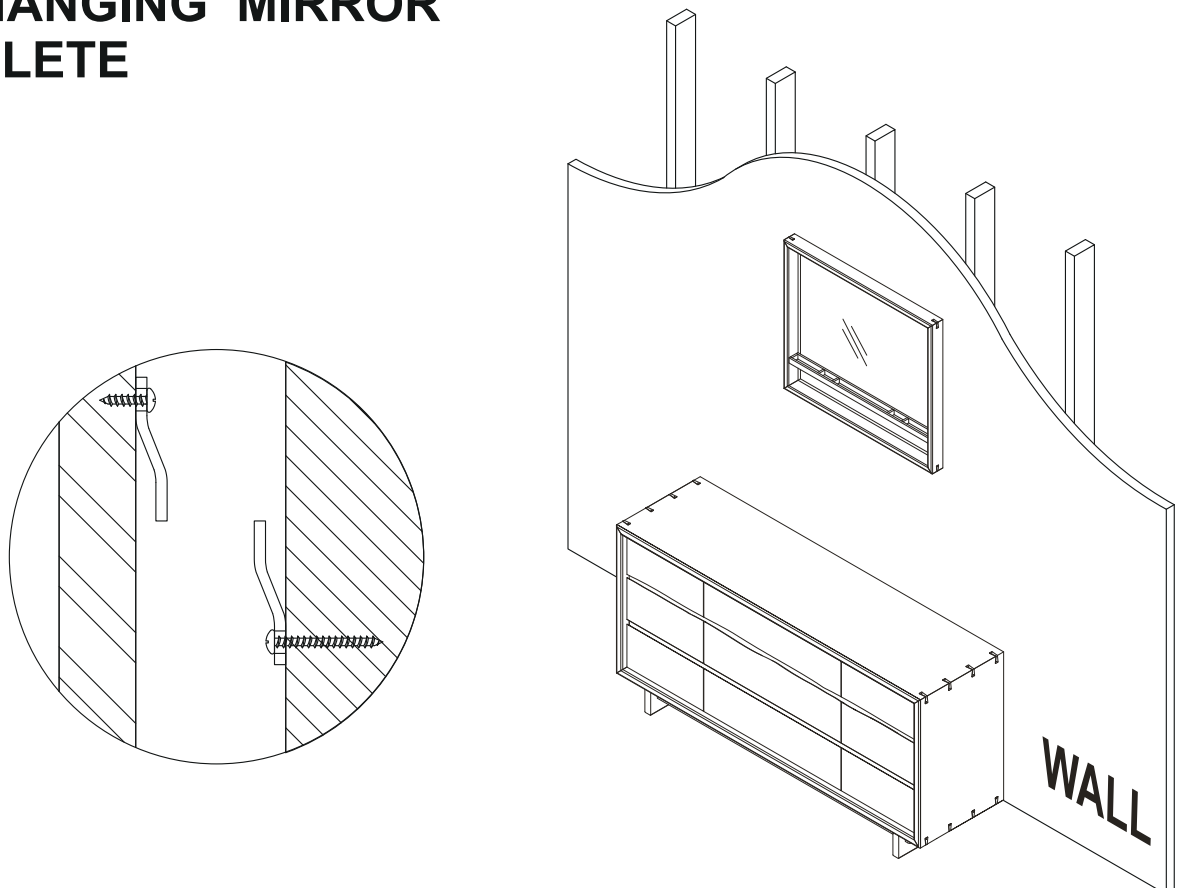

ITEM: 222804

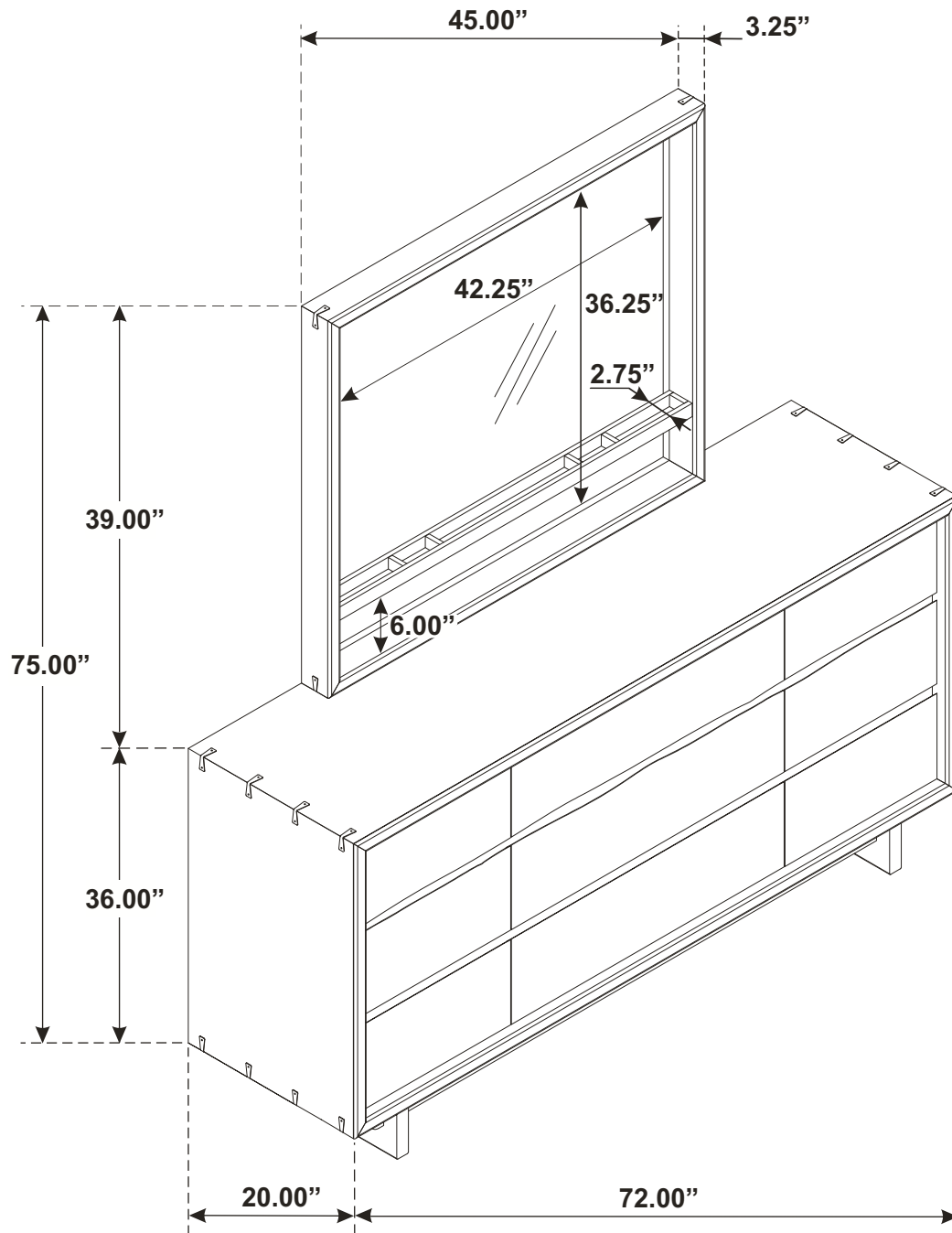

Note: Dimension tolerance  $\pm 5\%$