

ASSEMBLY INSTRUCTIONS
COASTER FINE FURNITURE



Fine Furniture for every stage of life

225061KE (B1&B2)
Eastern King Bed

ITEM: 225061KE (B1&B2)



ASSEMBLY INSTRUCTIONS

ASSEMBLY TIPS:

1. Remove hardware from box and sort by size.
2. Please check to see that all hardware and parts are present prior to start of assembly.
3. Please follow attached instructions in the same sequence as numbered to assure fast & easy assembly.



WARNING!

1. Don't attempt to repair or modify parts that are broken or defective. Please contact the store immediately.
2. This product is for home use only and not intended for commercial establishments.







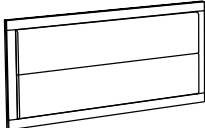

ASSEMBLY TIME

20 MINUTES



PARTS IDENTIFICATION

B1 (BOX 1)

A	HEADBOARD PANEL		1PC
B	FOOTBOARD PANEL		1PC
C	LEFT HEADBOARD LEG		1PC
D	RIGHT HEADBOARD LEG		1PC

E	FOOTBOARD SUPPORT BAR		1PC
F	BED SLAT		4PCS
G	BED SLAT SUPPORT WITH LEVELER		8PCS

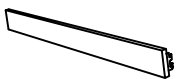
B2 (BOX 2)

H	LEFT BED RAIL		1PC
I	RIGHT BED RAIL		1PC

J	FOOTBOARD LEG		2PCS
---	---------------	---	------

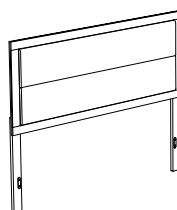
HB	225061KE(B1) FROM BOX 1 HEADBOARD COMPLETE		1PC
----	--	---	-----

FB	225061KE(B1) FROM BOX 1 FOOTBOARD COMPLETE		1PC
----	--	---	-----

NOTE:

Phillips head screw driver is required in the assembly process; however, manufacturer does not provide this item.

ITEM: 225061KE (B1&B2)



ASSEMBLY INSTRUCTIONS

ASSEMBLY TIPS:

1. Remove hardware from box and sort by size.
2. Please check to see that all hardware and parts are present prior to start of assembly.
3. Please follow attached instructions in the same sequence as numbered to assure fast & easy assembly.







WARNING!



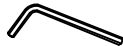

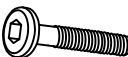

1. Don't attempt to repair or modify parts that are broken or defective. Please contact the store immediately.
2. This product is for home use only and not intended for commercial establishments.

HARDWARE IDENTIFICATION

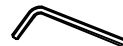
Z-B1 (BOX 1) - HARDWARE PACK IS LOCATED IN 225061KE (B1)

1	SMALL ALLEN WRENCH (M4 x 65mm - BLK)		1PC	4	LOCK WASHER (1/4" - BLK)		6PCS
2	BIG ALLEN WRENCH (M5 x 65mm - BLK)		1PC	5	FLAT WASHER (1/4" ID x 13mm - BLK)		6PCS
3	SHORT BOLT (M6 x 35mm - BLK)		6PCS				

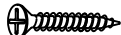
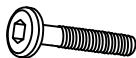
Z-B2 (BOX 2) - HARDWARE PACK IS LOCATED IN 225061KE (B2)

6	SMALL ALLEN WRENCH (M4 x 65mm - BLK)		1PC	10	LOCK WASHER (1/4" - BLK)		6PCS
7	BIG ALLEN WRENCH (M5 x 65mm - BLK)		1PC	11	FLAT WASHER (1/4" ID x 13mm - BLK)		6PCS
8	LONG BOLT (M6 x 80mm - BLK)		2PCS	12	SHORT FLAT HEAD SCREW (M4 x 32mm - RBW)		8PCS
9	MEDIUM BOLT (M6 x 50mm - BLK)		4PCS	13	LONG FLAT HEAD SCREW (M4 x 50mm - RBW)		4PCS

NOTE:

Phillips head screw driver is required in the assembly process; however, manufacturer does not provide this item.

ITEM: 225061KE (B1&B2)



ASSEMBLY INSTRUCTIONS

STEP 1

Note : Please take note of the marking sticker (L&R) on the headboard legs.

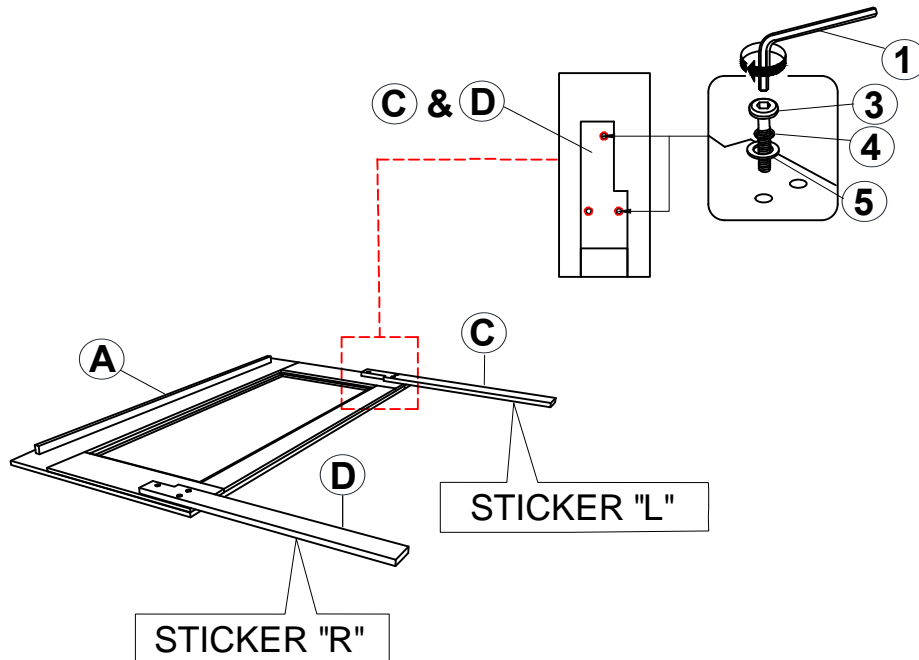

****BACK VIEW****

STEP 2

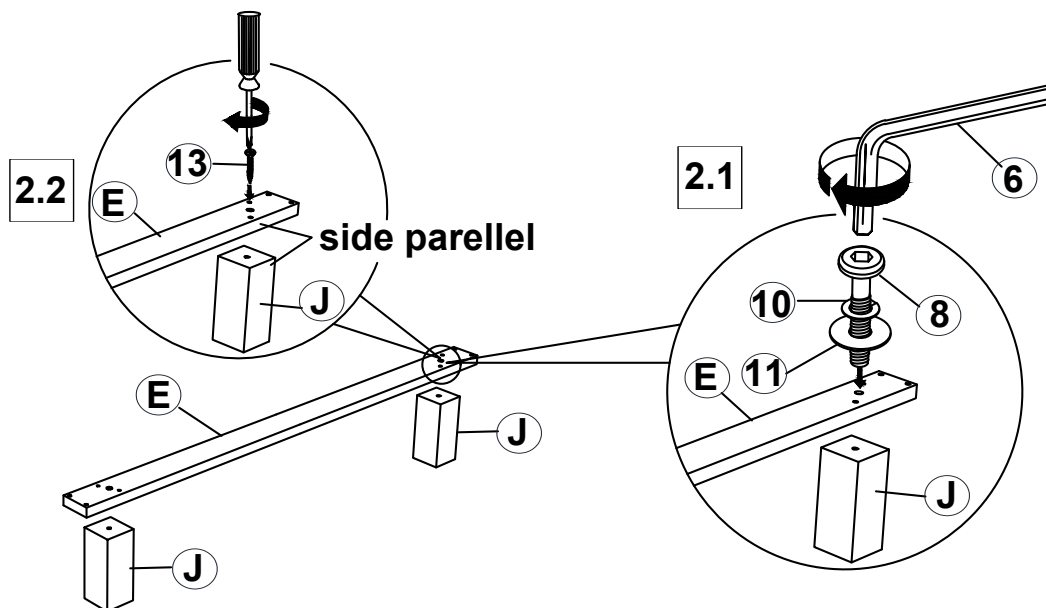

ITEM: 225061KE (B1&B2)

ASSEMBLY INSTRUCTIONS

STEP 3

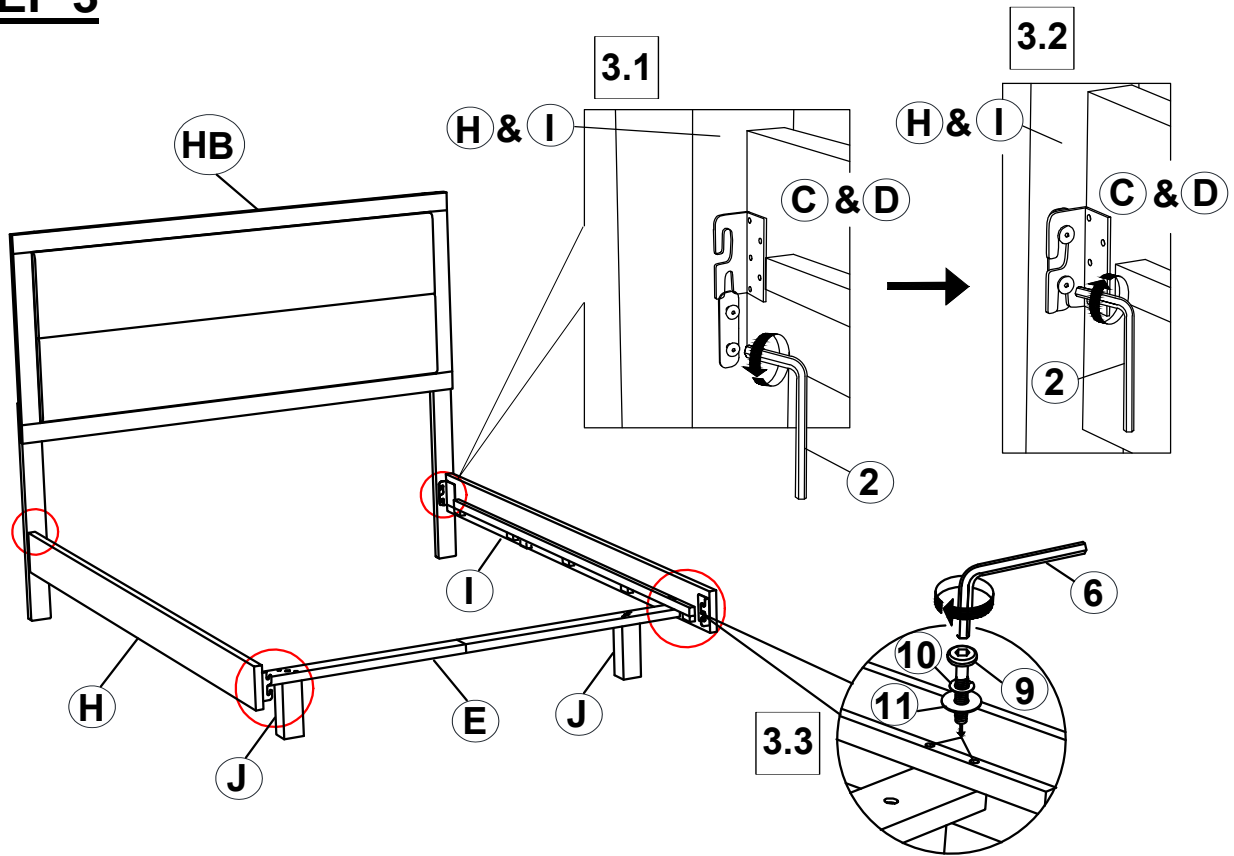

STEP 4

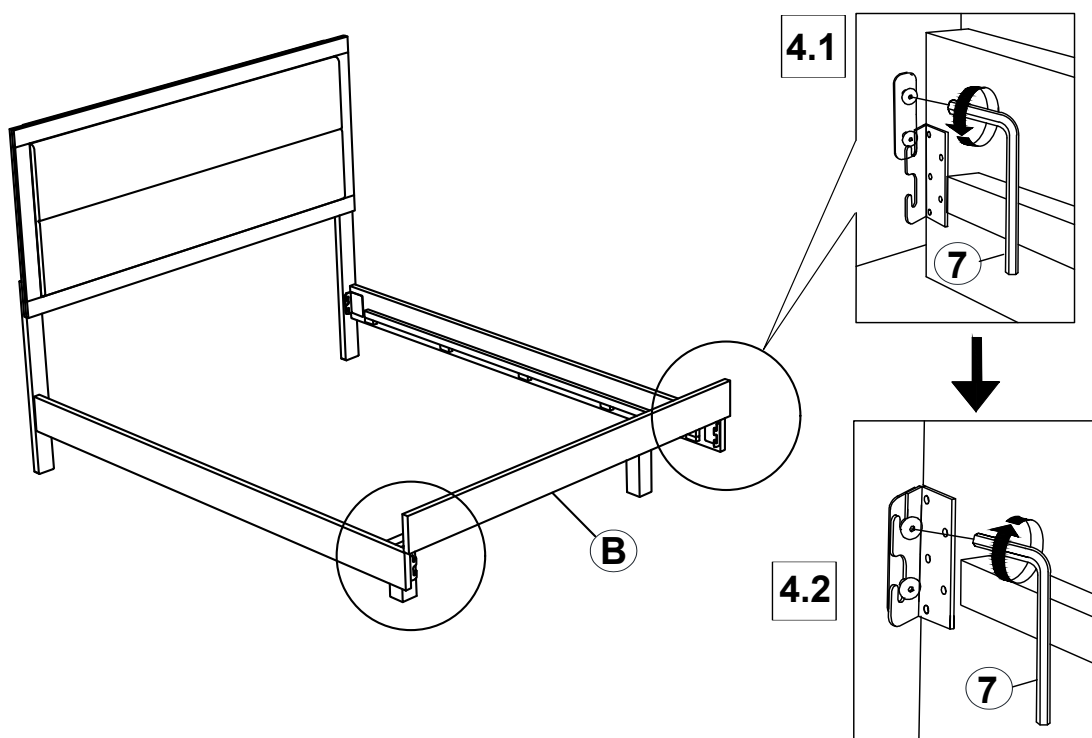

ITEM: 225061KE (B1&B2)



ASSEMBLY INSTRUCTIONS

STEP 5

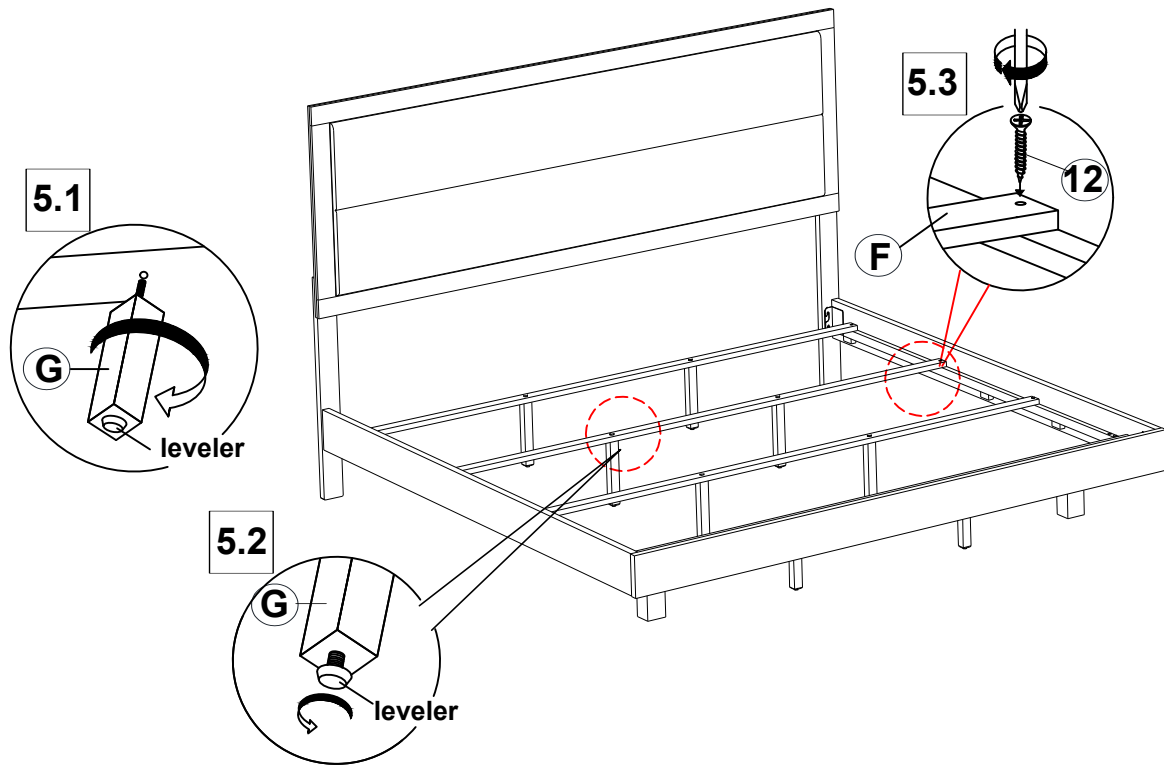

STEP 6 COMPLETE

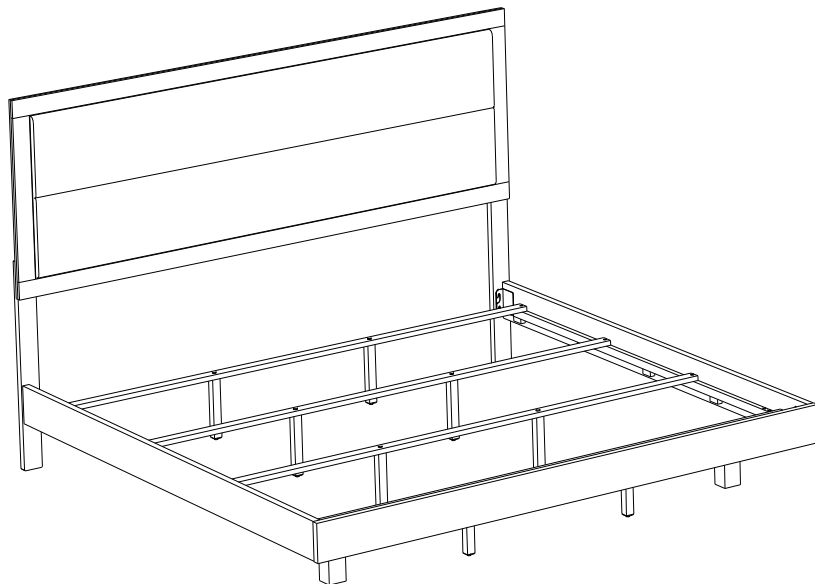

ITEM: **225061KE (B1&B2)**



Inner Size : 77.00"W X 80.50"D

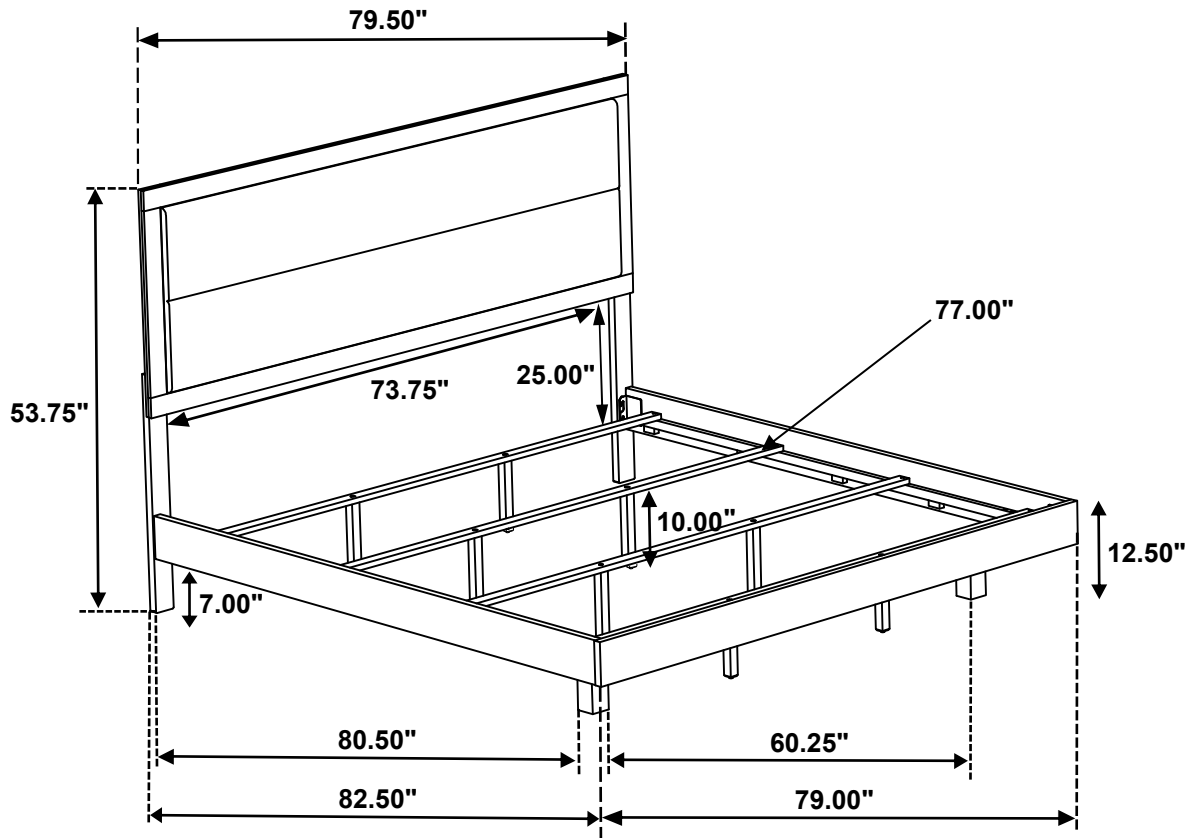

Note : Dimension tolerance $\pm 5\%$