

**ASSEMBLY INSTRUCTIONS**  
**COASTER FINE FURNITURE**



*Fine Furniture for every stage of life*

**2300**  
**BAR TABLE**

## ASSEMBLY INSTRUCTIONS

### ASSEMBLY TIPS:

1. Remove hardware from box and sort by size.
2. Please check to see that all hardware and parts are present prior to start of assembly.
3. Please follow attached instructions in the same sequence as numbered to assure fast & easy assembly.



### WARNING!

1. Don't attempt to repair or modify parts that are broken or defective. Please contact the store immediately.
2. This product is for home use only and not intended for commercial establishments.



**ASSEMBLY TIME**

**10 MINUTES**

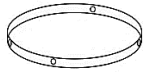
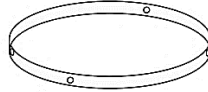
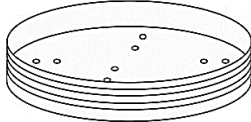
## PARTS IDENTIFICATION

A	LEG		4PCS
B	SMALL STRETCHER RING		1PC
C	LARGE STRETCHER RING		1PC
D	TABLE TOP		1PC

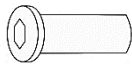
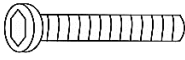
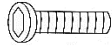
## HARDWARE IDENTIFICATION

1	BOLT NUT (1/4")		8PCS
2	BOLT (1/4" x 32mm)		8PCS
3	BOLT (1/4" x 15mm)		8PCS
4	CAP (1")		4PCS
5	WRENCH (4mm)		1PC

ITEM: **2300**

**ASSEMBLY INSTRUCTIONS**  
**STEP 1**

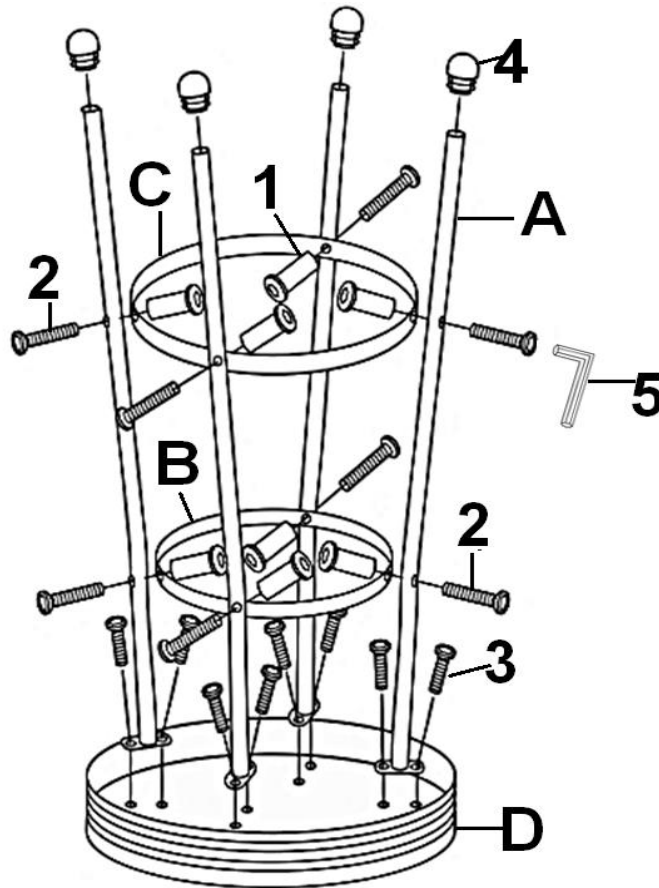

**STEP 2**

**COMPLETE**

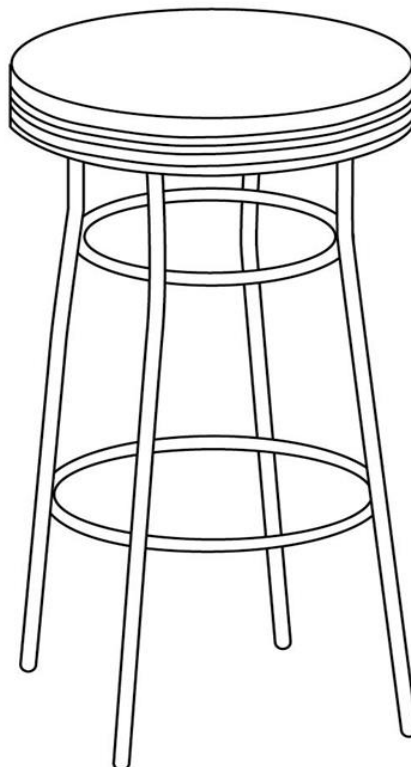

ITEM:2300

**COASTER**  
FINE FURNITURE

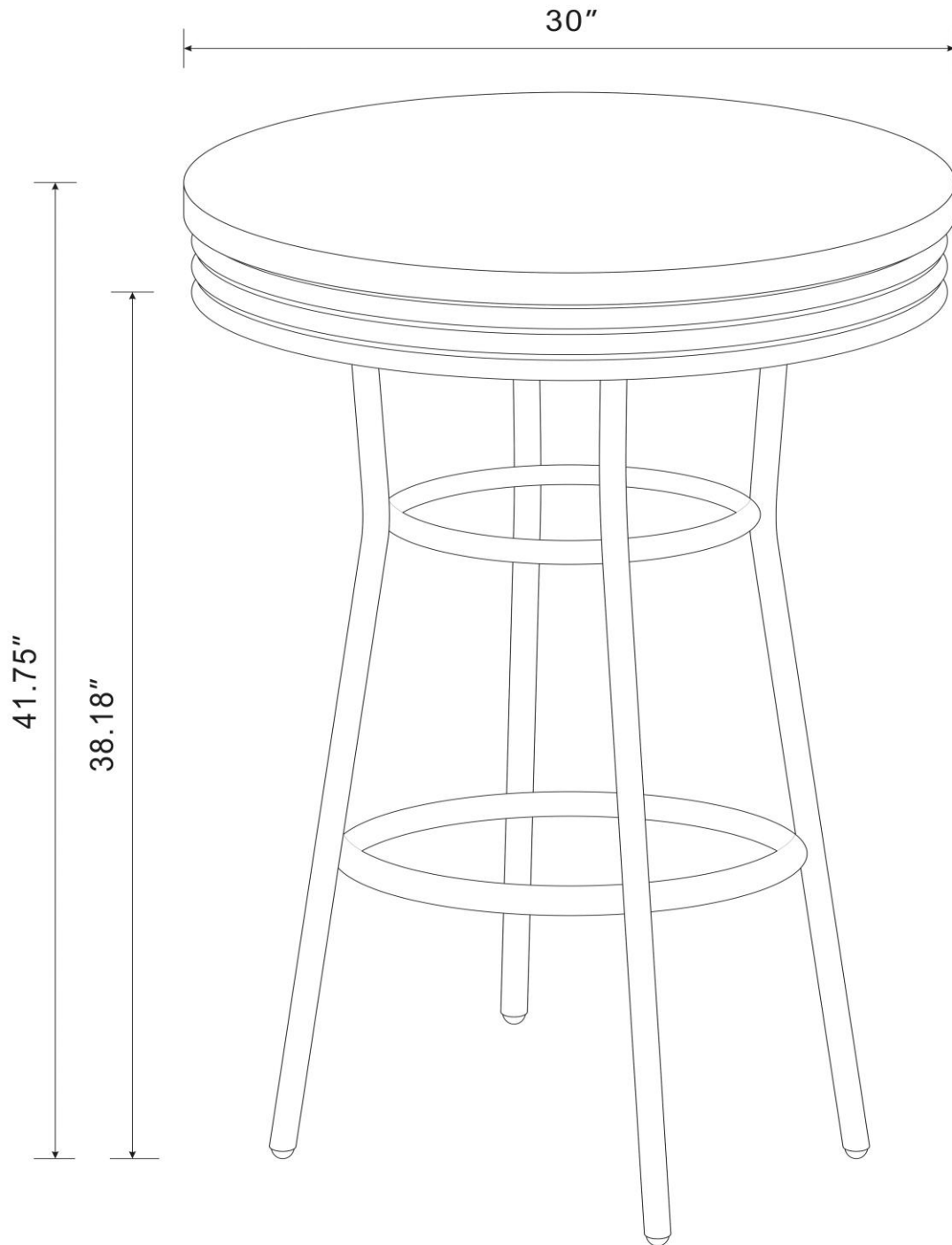

**Note :** Dimension tolerance  $\pm 5\%$

**ASSEMBLY INSTRUCTIONS**  
**COASTER FINE FURNITURE**



*Fine Furniture for every stage of life*

**2299W**  
**Bar Stool**

REVISION 0: 04/02/2018  
REVISION 1: 08/08/2022

# ITEM:2299W

## ASSEMBLY INSTRUCTIONS



### ASSEMBLY TIPS:

1. Remove hardware from box and sort by size.
2. Please check to see that all hardware and parts are present prior to start of assembly.
3. Please follow attached instructions in the same sequence as numbered to assure fast & easy assembly.

### WARNING!



1. Don't attempt to repair or modify parts that are broken or defective.  
Please contact the store immediately.
2. This product is for home use only and not intended for commercial establishments.

ASSEMBLY TIME

30 MINUTES

## PARTS IDENTIFICATION

AN

LOWER LEG

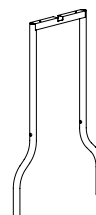

1PC

BN

UPPER LEG

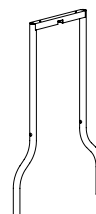

1PC

CN

SWIVEL PLATE



1PC

DN

BOTTOM RING



1PC

EN

CUSHION SEAT



1PC

**NOTE: QUANTITIES SHOWN ARE FOR ONE STOOL**

**ITEM:2299W**



**HARDWARE IDENTIFICATION**

1	ALLEN BOLT-LARGE (1/4" x 1-1/2"L - SR)		8PCS
2	ALLEN BOLT-SMALL (1/4" x 3/4"L - SR)		4PCS
3	SCREW TUBE (1/4" x 5/8"L - SR)		4PCS
4	WASHER (Φ18mm - SR)		4PCS
5	HEX NUT (5 x 10H mm - SR)		4PCS
6	PLASTIC END CAP (Φ25 x 22mm - BLK)		4PCS
7	ALLEN WRENCH (4 x 20W x 57L mm - SR)		2PCS
8	OPEN END WRENCH (60 x 15mm - SR)		1PC

**NOTE: QUANTITIES SHOWN ARE FOR ONE STOOL**

# ITEM:2299W

## ASSEMBLY INSTRUCTIONS

### STEP 1

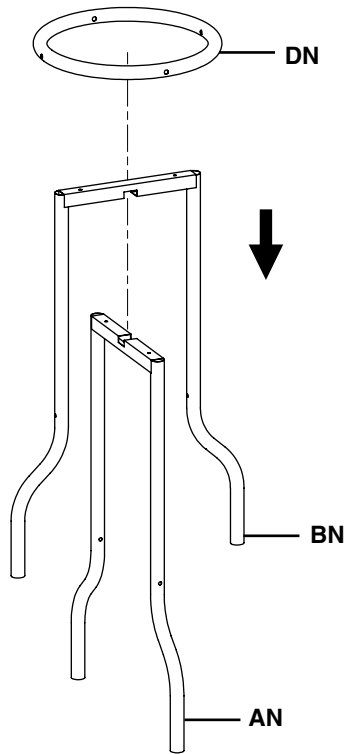

### STEP 2

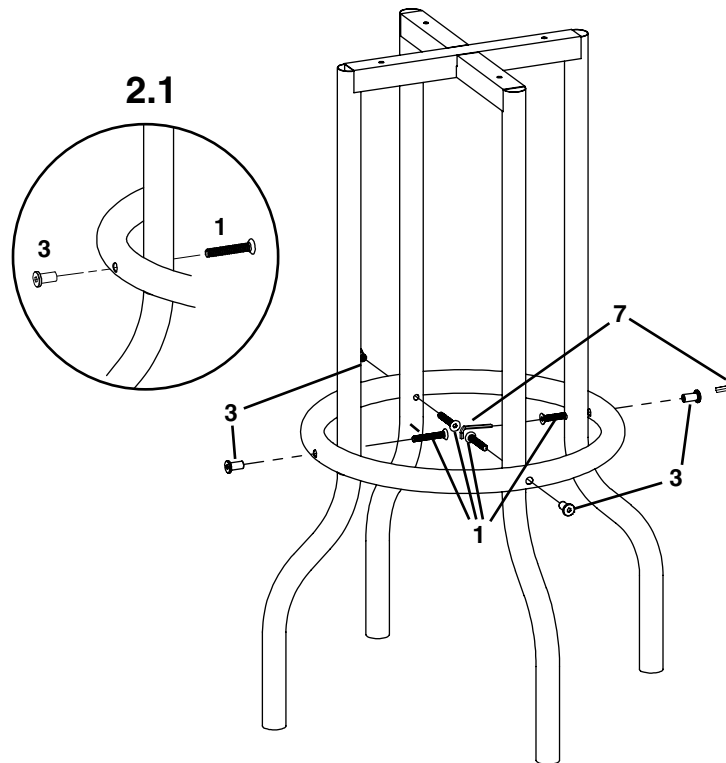

**ITEM:2299W**

**ASSEMBLY INSTRUCTIONS**



**STEP 3**

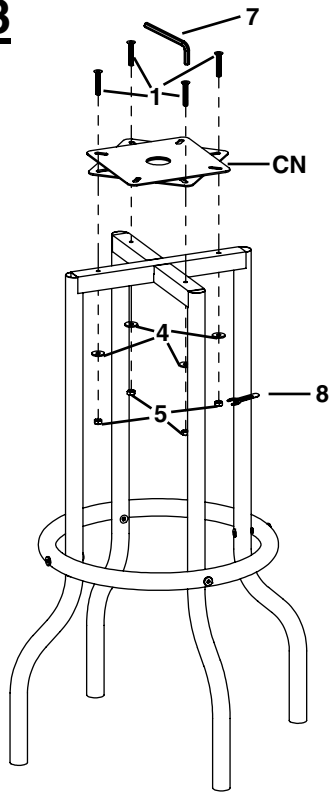

**STEP 4**

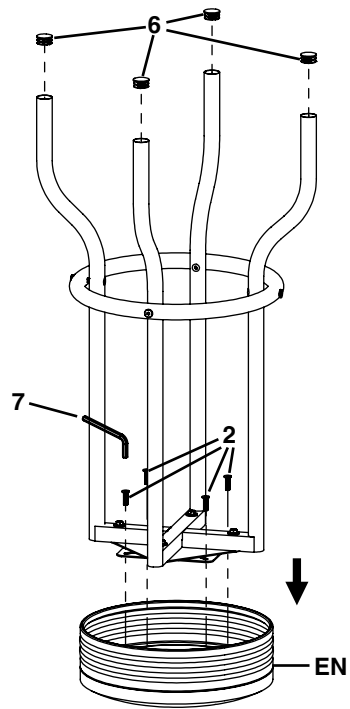

**STEP 5**  
**COMPLETE**

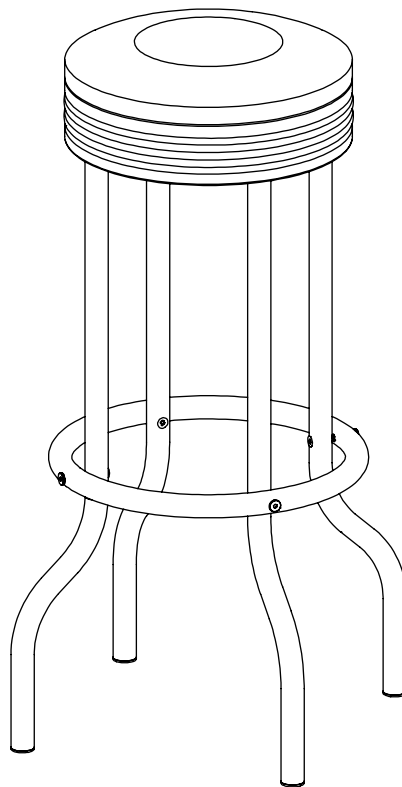

ITEM:2299W

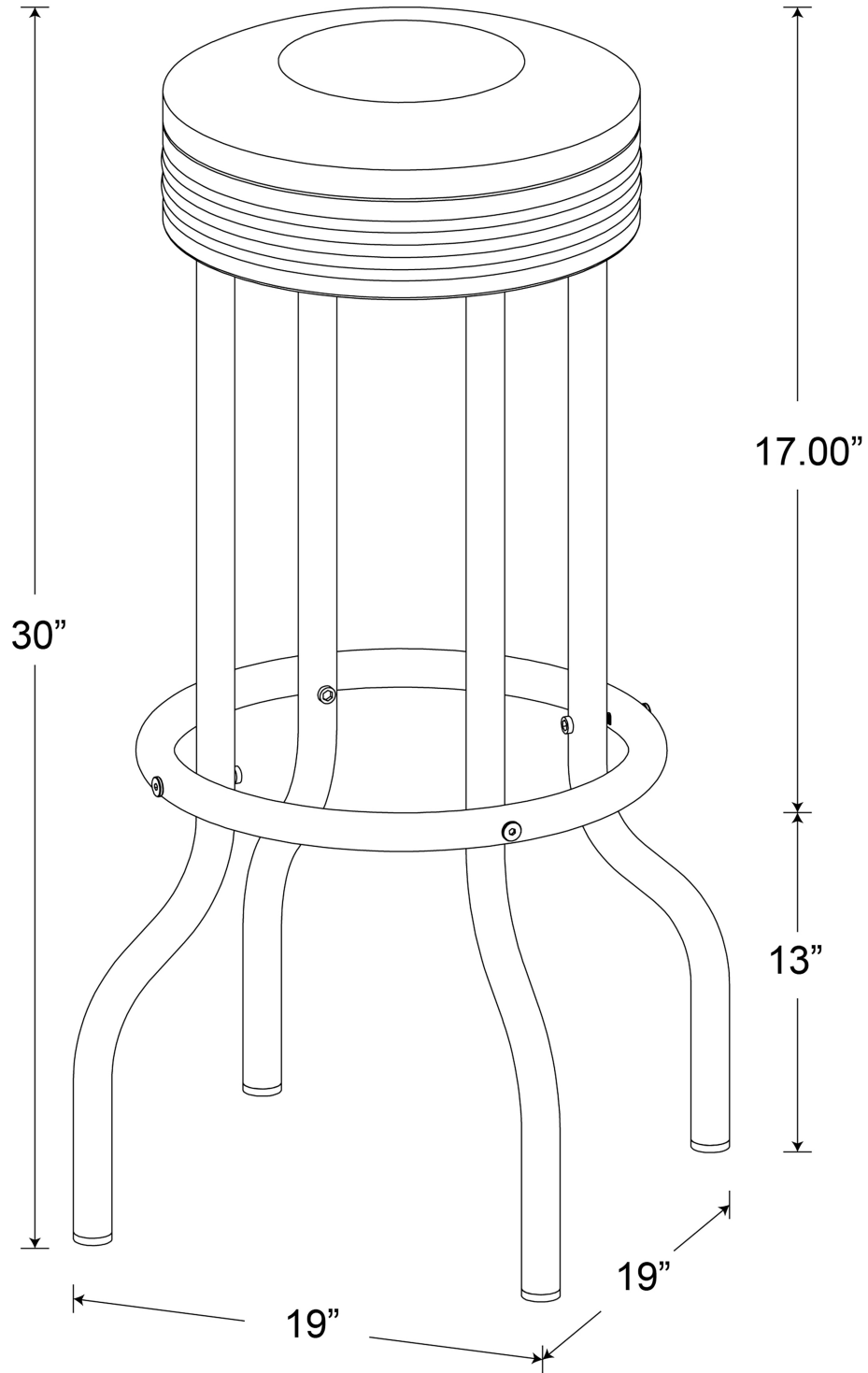

Note : Dimension tolerance  $\pm 5\%$