

INSTRUCTIONS D'ASSEMBLAGE
ASSEMBLY INSTRUCTIONS



Fine Furniture for every stage of life

224452/224452S
Table De Nuit
Nightstand

ITEM: **224452/224452S**



INSTRUCTIONS D'ASSEMBLAGE/ASSEMBLY INSTRUCTIONS

TRUCS POUR L'ASSEMBLAGE/ASSEMBLY TIPS:

1. Retirer le matériel de la boîte et le trier par taille.
Remove hardware from box and sort by size.
2. Vérifier qu'il ne manque aucune pièce ou de matériel avant de commencer l'assemblage.
Please check to see that all hardware and parts are present prior to start of assembly.
3. Suivre les instructions ci-dessous pour un assemblage facile et rapide.
Please follow attached instructions in the same sequence as numbered to assure fast & easy assembly.





ATTENTION / WARNING!

1. Ne tentez pas de réparer ou de modifier les pièces brisées ou défectueuses. Communiquez avec le magasin en cas de problème.
Don't attempt to repair or modify parts that are broken or defective. Please contact the store immediately.
2. Ce produit est destiné à un usage domestique seulement.
This product is for home use only and not intended for commercial establishments.

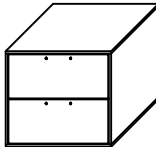

TEMPS D'ASSEMBLAGE	10 MINUTES
ASSEMBLY TIME	

IDENTIFICATION DES PIÈCES / PARTS IDENTIFICATION

A	TABLE DE NUIT/NIGHTSTAND		1PC
B	PIED/LEG		4PCS

IDENTIFICATION DU MATÉRIEL/HARDWARE IDENTIFICATION

1	BOULON/BOLT (M6 x 15MM - RBW)		8PCS
2	RONDELLE PLATE/FLAT WASHER (1/4" x 19 Ø - RBW)		8PCS
3	CLÉ ALLEN/ALLEN WRENCH (M4 x 65MM - BLK)		1PC

NOTE :

Un tournevis à tête Philips est nécessaire pour le montage, mais le fabricant ne le fournit pas.
Philips head screw driver is required in the assembly process; however, manufacturer does not provide this item.

ITEM: **224452/224452S**

INSTRUCTIONS D'ASSEMBLAGE/ASSEMBLY INSTRUCTIONS



ÉTAPE / STEP 1

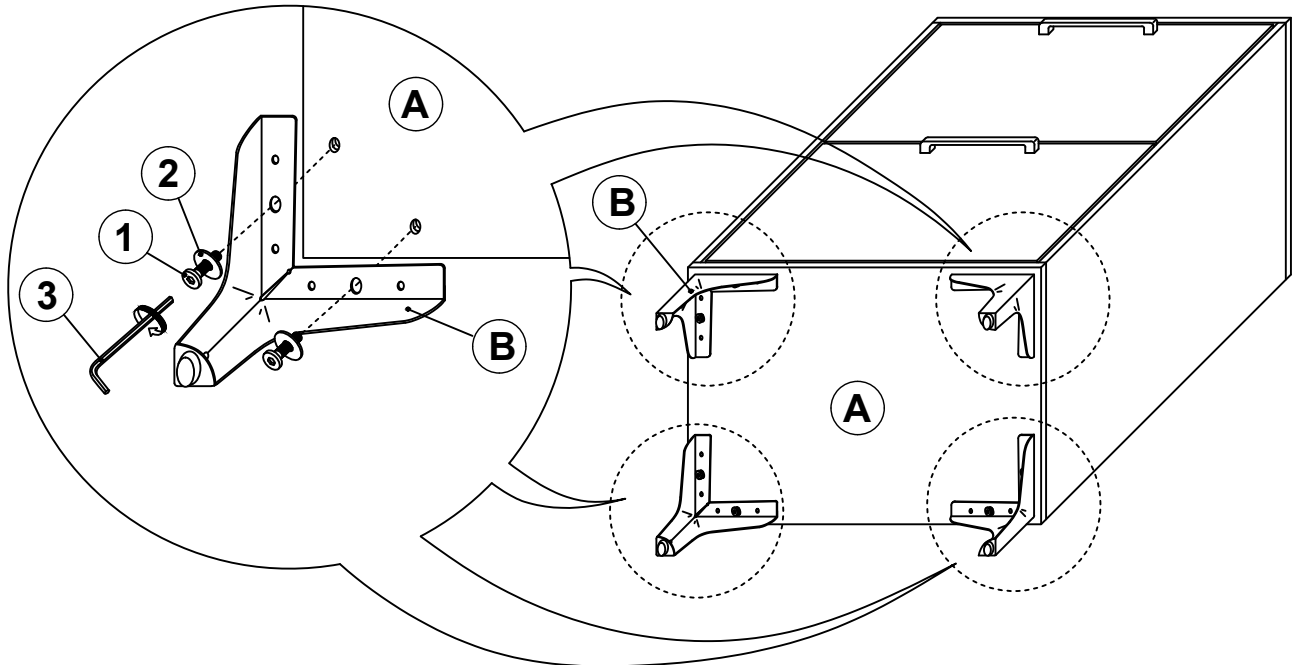

ÉTAPE / STEP 2

ASSEMBLAGE TERMINÉ / COMPLETE

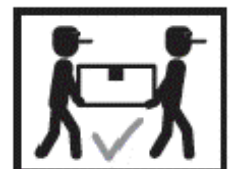
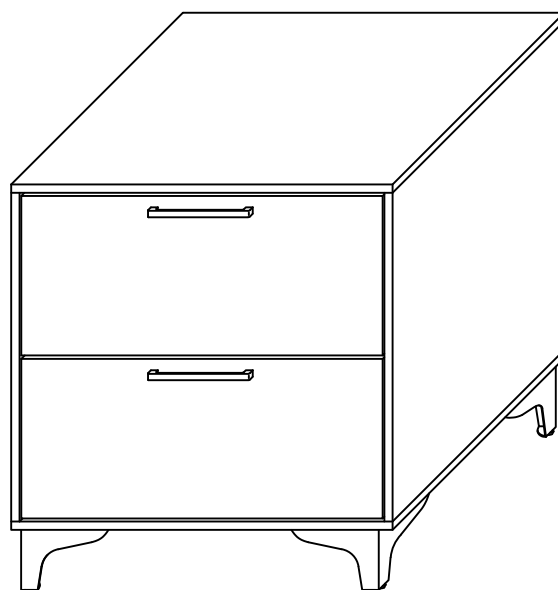

ITEM: **224452/224452S**

COASTER
FINE FURNITURE

Dimension Intérieure du tiroir/Inner Size of Drawer:
15.00"W X 12.25"D X 5.00"H X 0.25"T

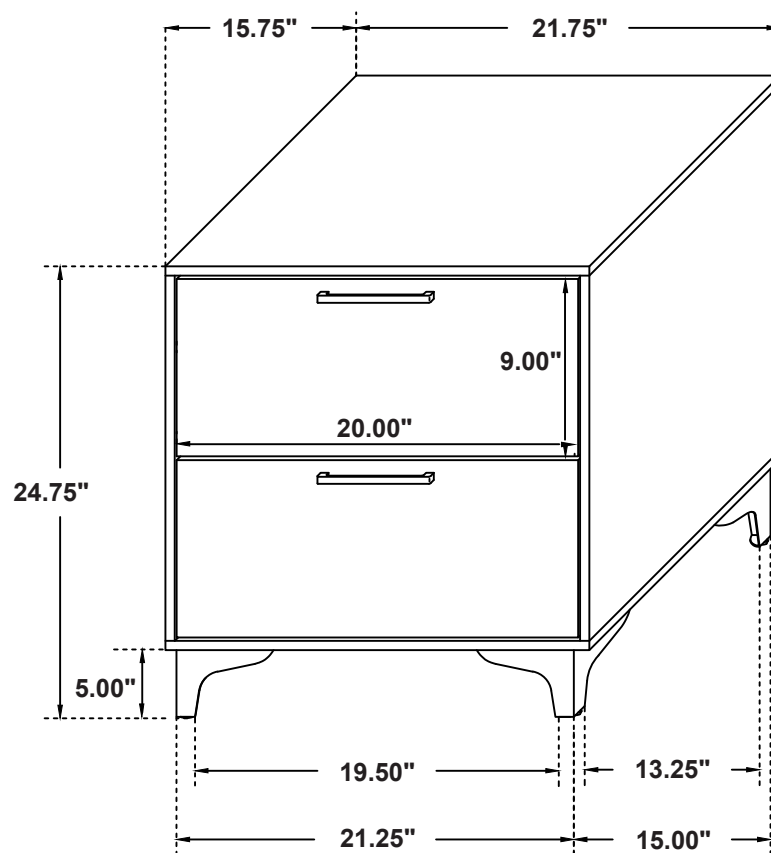

Note : Tolérance dimensionnelle / Dimension tolerance $\pm 5\%$



INSTRUCTIONS D'ASSEMBLAGE
ASSEMBLY INSTRUCTIONS



Fine Furniture for every stage of life

224453/224453S
Commode
Dresser

ITEM: **224453/224453S**



INSTRUCTIONS D'ASSEMBLAGE/ASSEMBLY INSTRUCTIONS

TRUCS POUR L'ASSEMBLAGE/ASSEMBLY TIPS:

1. Retirer le matériel de la boîte et le trier par taille.
Remove hardware from box and sort by size.
2. Vérifier qu'il ne manque aucune pièce ou de matériel avant de commencer l'assemblage.
Please check to see that all hardware and parts are present prior to start of assembly.
3. Suivre les instructions ci-dessous pour un assemblage facile et rapide.
Please follow attached instructions in the same sequence as numbered to assure fast & easy assembly.



ATTENTION / WARNING!

1. Ne tentez pas de réparer ou de modifier les pièces brisées ou défectueuses. Communiquez avec le magasin en cas de problème.
Don't attempt to repair or modify parts that are broken or defective. Please contact the store immediately.
2. Ce produit est destiné à un usage domestique seulement.
This product is for home use only and not intended for commercial establishments.



TEMPS D'ASSEMBLAGE	10 MINUTES
ASSEMBLY TIME	

IDENTIFICATION DES PIÈCES / PARTS IDENTIFICATION

A	COMMODE DRESSER		1PC
B	SUPPORT DE LATTE DE LIT AVEC NIVELLEUR CENTER SUPPORT LEG WITH LEVELER		1PC
C	PIED/LEG		4PCS

IDENTIFICATION DU MATÉRIEL/HARDWARE IDENTIFICATION

1	BOULON/BOLT (M6 x 15MM - RBW)		8PCS
2	RONDELLE PLATE/FLAT WASHER (1/4" x 19 Ø - RBW)		8PCS
3	CLÉ ALLEN/ALLEN WRENCH (M4 x 65MM - BLK)		1PC

NOTE :

Un tournevis à tête Philips est nécessaire pour le montage, mais le fabricant ne le fournit pas.
Philips head screw driver is required in the assembly process; however, manufacturer does not provide this item.

ITEM: **224453/224453S**

INSTRUCTIONS D'ASSEMBLAGE/ASSEMBLY INSTRUCTIONS

COASTER
FINE FURNITURE

ÉTAPE / STEP 1

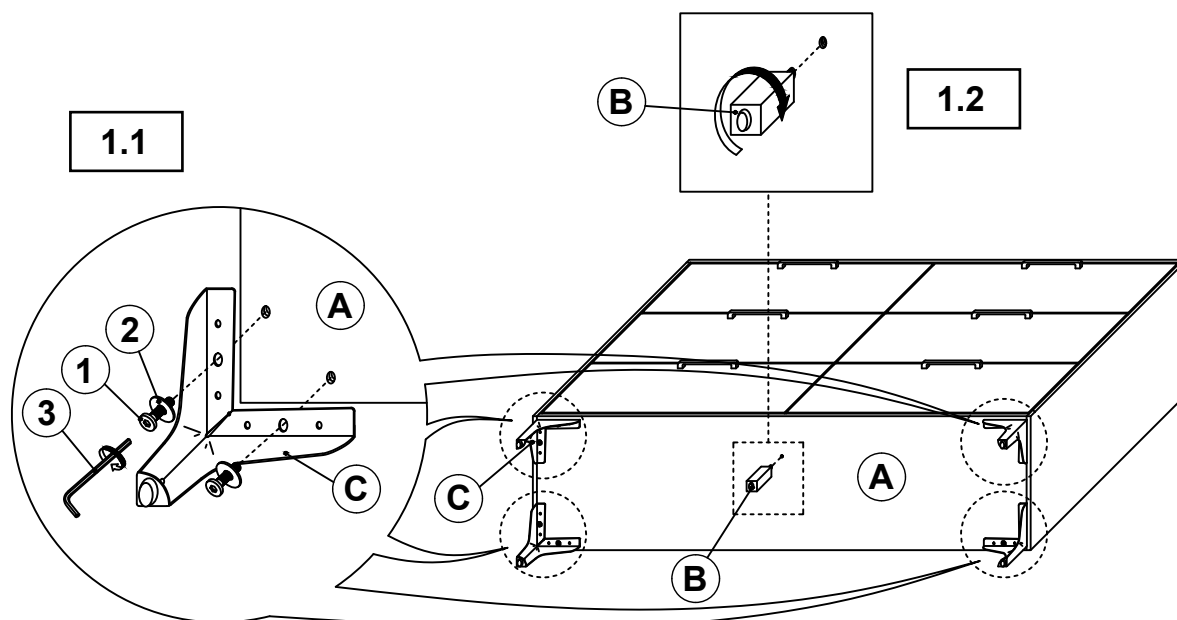

ÉTAPE / STEP 2

ASSEMBLAGE TERMINÉ / COMPLETE

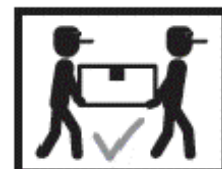
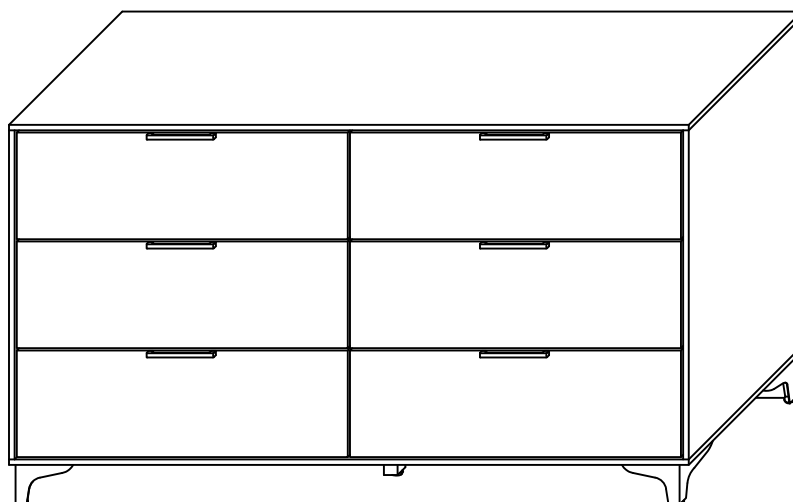

ITEM: **224453/224453S**

COASTER
FINE FURNITURE

INSTRUCTIONS D'INSTALLATION DU SYSTÈME ANTI-BASCULEMENT DISPOSITIF DE RETENUE DU BASCULEMENT DES

AVERTISSEMENT

Le basculement d'un meuble peut entraîner des blessures.

Ce dispositif de retenue peut protéger contre le basculement des meubles.

Ne laissez pas les enfants grimper sur les meubles.

Ce dispositif de retenue ne remplace pas la surveillance d'un adulte.

Le fait de ne pas détacher ce dispositif de retenue avant de déplacer le meuble peut entraîner des blessures et des dommages.

1. Fixez solidement l'un des supports de montage sur le bord arrière du meuble. Utilisez la vis courte.
2. Déterminez l'endroit où le meuble doit être placé et marquez l'emplacement sur le mur pour le trou de vis du support de montage environ 2 pouces sous le support fixé au bord du meuble.
3. Percez un trou de 3/16" dans le mur. Enfoncez la cheville en plastique dans le trou et tapez doucement jusqu'à ce que la bride de la cheville soit contre la surface du mur.
4. Positionnez le support sur la cheville murale et utilisez la longue vis pour fixer solidement le support au mur.
5. Placez le meuble de sorte que le support sur le bord arrière soit aligné avec le support sur le mur.
6. Passez une extrémité de l'attache-câbles à travers chaque support. Rassemblez les deux extrémités et faites glisser l'extrémité perlée de l'attache-câbles dans la fente en forme de trou de serrure de l'autre extrémité jusqu'à ce qu'elle soit bien ajustée. Tirez vers le bas jusqu'à ce qu'elle s'enclenche dans la fente en forme de trou de serrure.
7. Pour effectuer un double verrouillage, remettez l'extrémité en forme de perle dans le trou de serrure comme indiqué.
8. Vérifiez que l'attache-câbles est bien attachée et verrouillée aux supports.

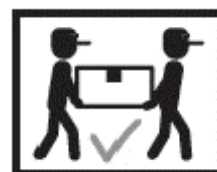
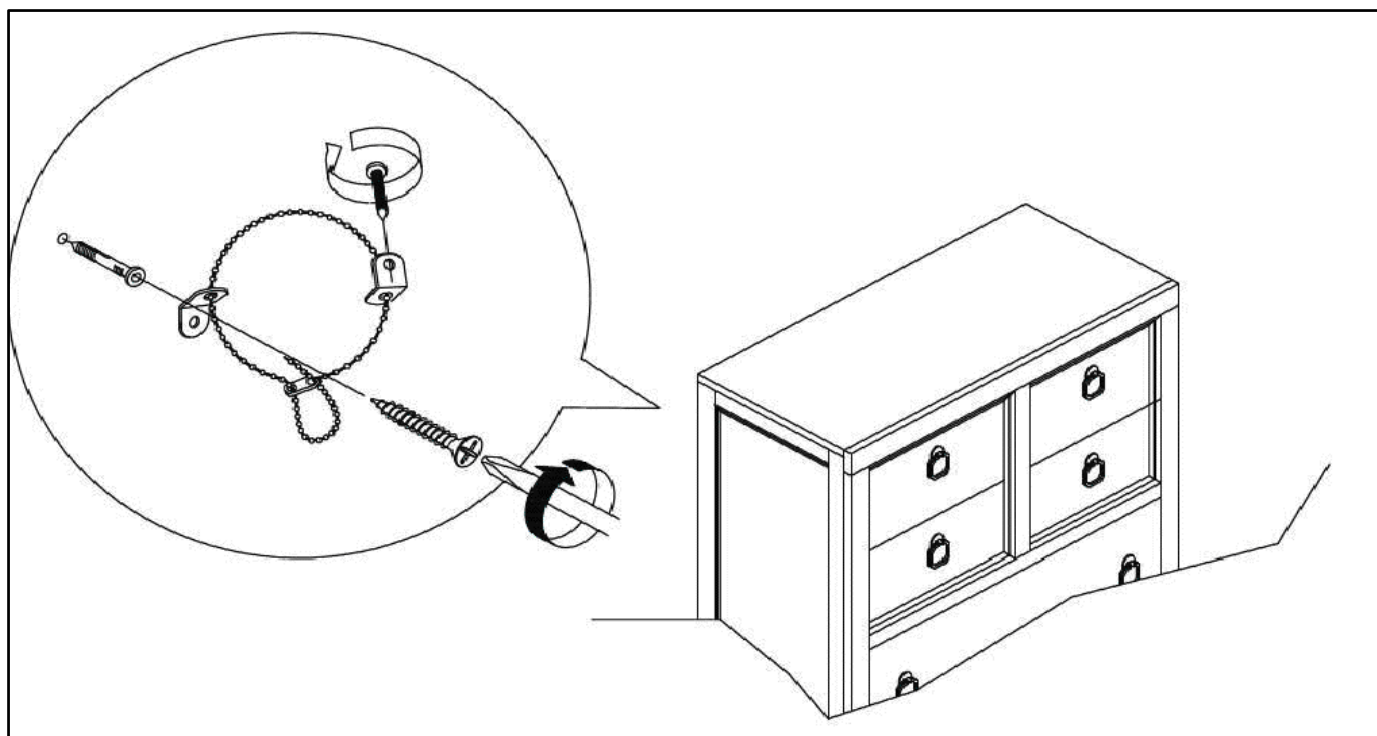

ITEM: **224453/224453S**



ANTI-TIPPING INSTALLMENT INSTRUCTIONS

FURNITURE TIPPING RESTRAINT

WARNING

Injury may result from tipping furniture.
This restraint may protect against tipping furniture.
Do not allow children to climb on furniture.
This restraint is not a substitute for proper adult supervision.
Failure to detach this restraint before moving the furniture may result in injury and damage.

1. Attach one of the mounting brackets securely to the back edge of the furniture. Use the short screw.
2. Determine where the furniture is to be placed and mark location on the wall for the mounting bracket screw hole approximately 2" below the bracket mounted to the edge of the furniture.
3. Drill a 3/16" hole in the wall. Press the plastic wall plug into the hole and gently tap until the flange on the wall plug is against the wall surface.
4. Position the bracket over the wall plug and use the long screw to securely attach the bracket to the wall.
5. Place the furniture so the bracket on the back edge is in line with the bracket on the wall.
6. Lace an end of the cable tie down through each bracket. Bring both ends together and slide the beaded end of the cable tie through the keyhole shaped slot on the other end until snug. Pull down on the beaded end until it snap locks into the keyhole slot.
7. To double lock return the beaded end back through the keyhole as shown.
8. Check to make sure the cable tie is securely laced and locked to the brackets.

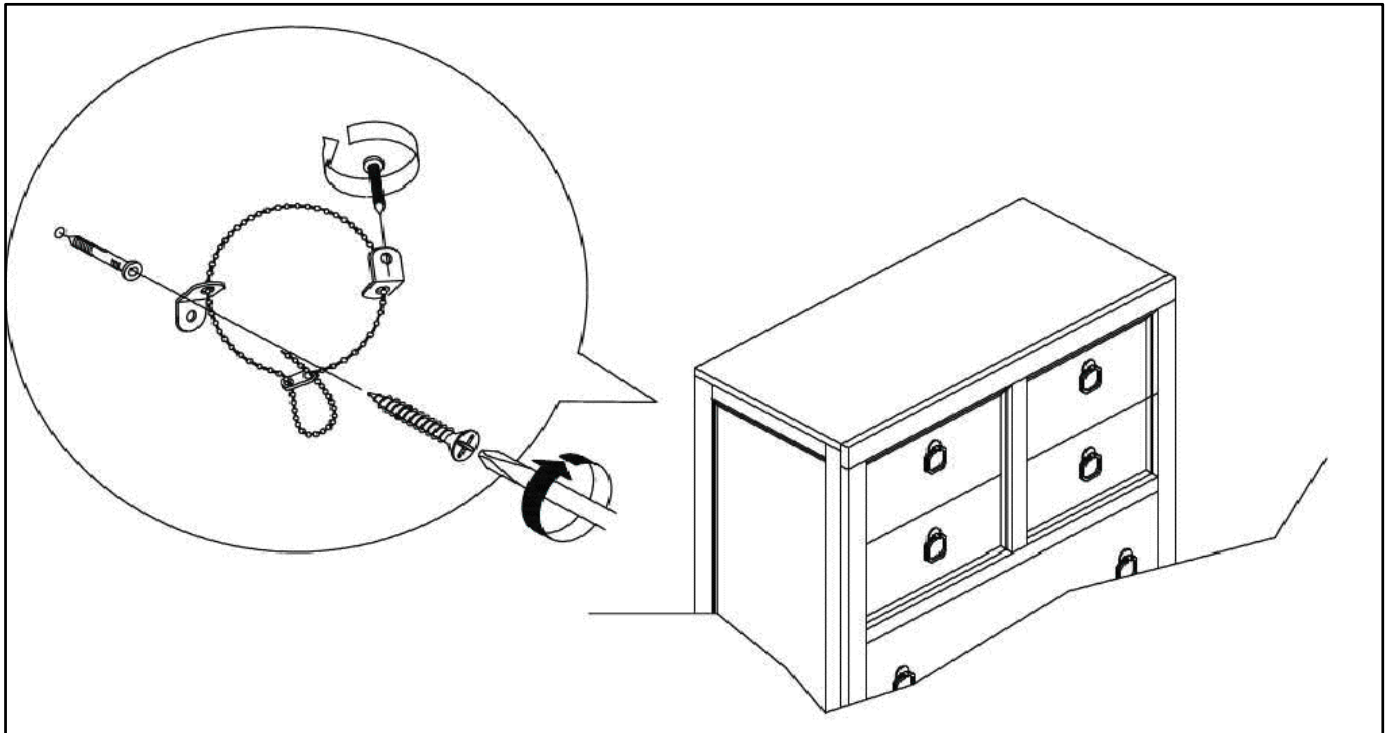

ITEM: **224453/224453S**

COASTER
FINE FURNITURE

Dimension Intérieure du tiroir/Inner Size of Drawer:
24.50"W X 12.25"D X 5.00"H X 0.25"T

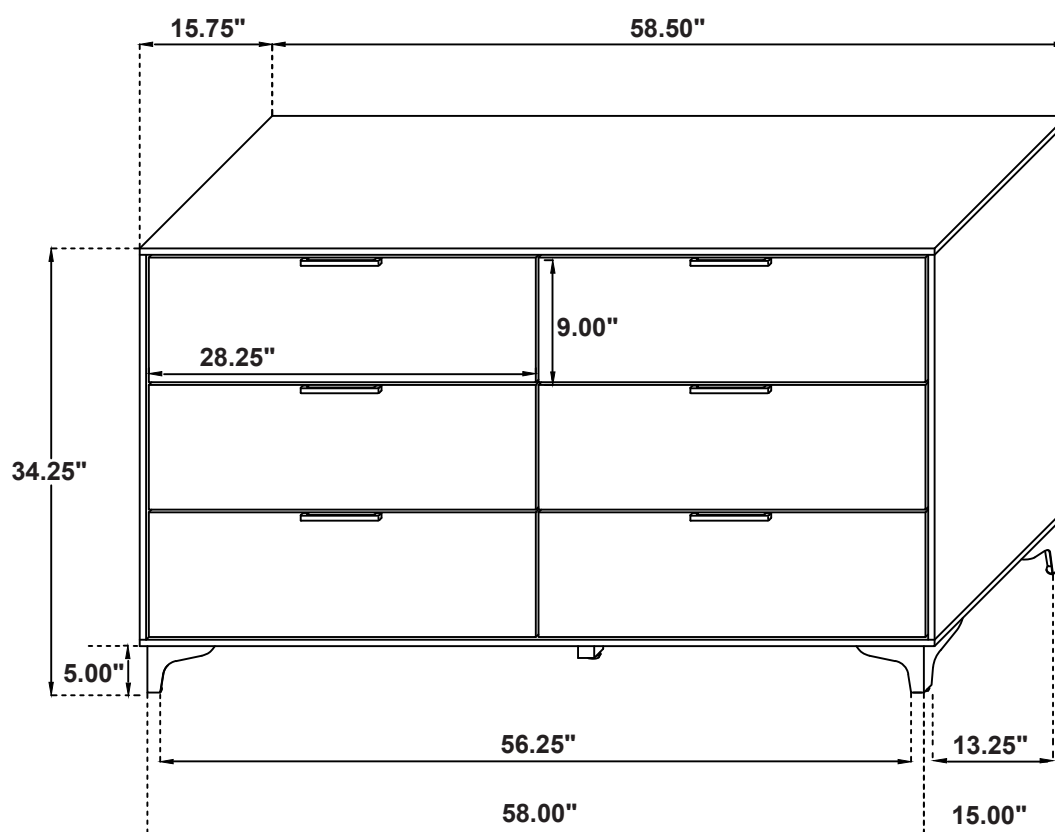

Note : Tolérance dimensionnelle / Dimension tolerance $\pm 5\%$

INSTRUCTIONS D'ASSEMBLAGE
ASSEMBLY INSTRUCTIONS



Fine Furniture for every stage of life

224454/224454S
Miroir
Mirror

ITEM: **224454/224454S**



INSTRUCTIONS D'ASSEMBLAGE/ASSEMBLY INSTRUCTIONS

TRUCS POUR L'ASSEMBLAGE/ASSEMBLY TIPS:

1. Retirer le matériel de la boîte et le trier par taille.
Remove hardware from box and sort by size.
2. Vérifier qu'il ne manque aucune pièce ou de matériel avant de commencer l'assemblage.
Please check to see that all hardware and parts are present prior to start of assembly.
3. Suivre les instructions ci-dessous pour un assemblage facile et rapide.
Please follow attached instructions in the same sequence as numbered to assure fast & easy assembly.



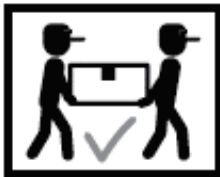

ATTENTION / WARNING!

1. Ne tentez pas de réparer ou de modifier les pièces brisées ou défectueuses. Communiquez avec le magasin en cas de problème.
Don't attempt to repair or modify parts that are broken or defective. Please contact the store immediately.
2. Ce produit est destiné à un usage domestique seulement.
This product is for home use only and not intended for commercial establishments.





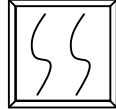

TEMPS D'ASSEMBLAGE	10 MINUTES
ASSEMBLY TIME	

IDENTIFICATION DES PIÈCES / PARTS IDENTIFICATION

A	MIROIR MIRROR		1PC
B	SUPPORT DE MIROIR (EMBALLÉ AVEC MIROIR) MIRROR SUPPORT (PACKED WITH MIRROR)		2PCS
C	BUREAU DOUBLE DE LA BOITE # 224453 DRESSER FROM BOX ITEM 224453		1PC

IDENTIFICATION DU MATÉRIEL/HARDWARE IDENTIFICATION

1	BOULON/BOLT (M6 x 40MM - RBW)		8PCS
2	RONDELLE DE VÉROUILLAGE/LOCK WASHER (1/4" x 13 Ø - RBW)		8PCS
3	RONDELLE PLATE/FLAT WASHER (1/4" x 19 Ø - RBW)		8PCS
4	CLÉ ALLEN/ALLEN WRENCH (M4 x 65MM - BLK)		1PC

NOTE :

Un tournevis à tête Philips est nécessaire pour le montage, mais le fabricant ne le fournit pas.
Philips head screw driver is required in the assembly process; however, manufacturer does not provide this item.

ITEM: **224454/224454S**

COASTER
FINE FURNITURE

INSTRUCTIONS D'ASSEMBLAGE/ASSEMBLY INSTRUCTIONS

ÉTAPE / STEP 1

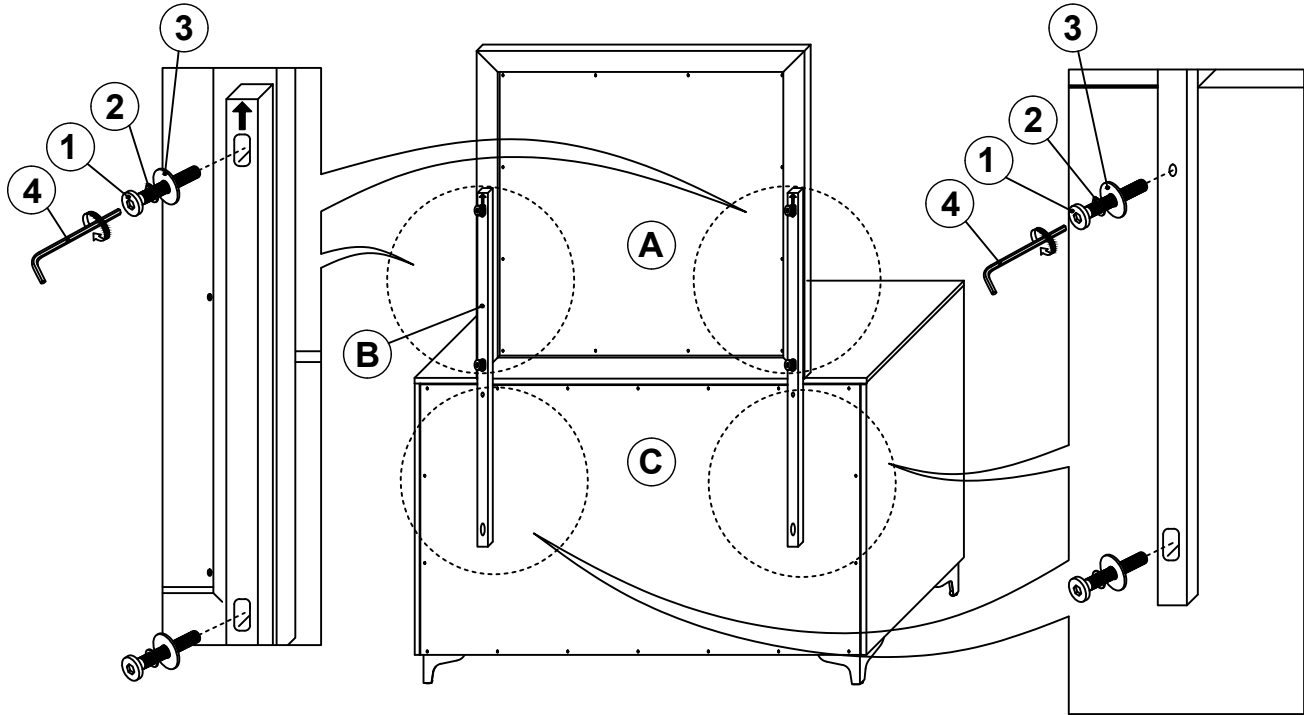

ÉTAPE / STEP 2

ASSEMBLAGE TERMINÉ / COMPLETE

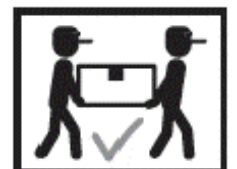
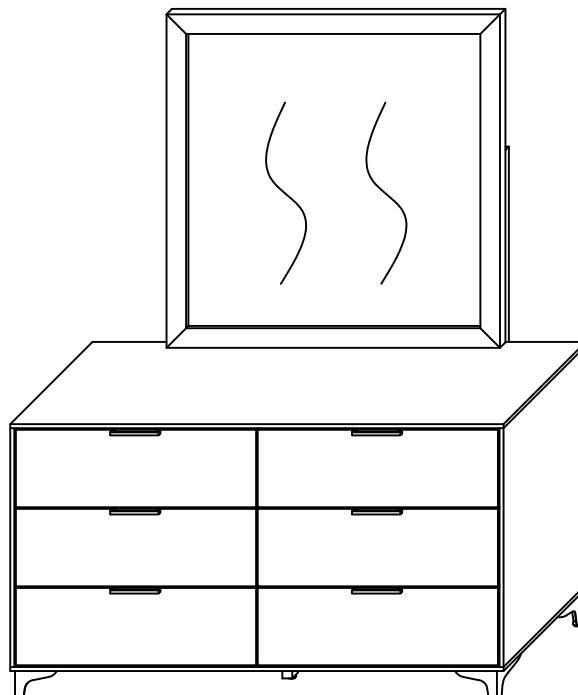

ITEM: **224454/224454S**

COASTER
FINE FURNITURE

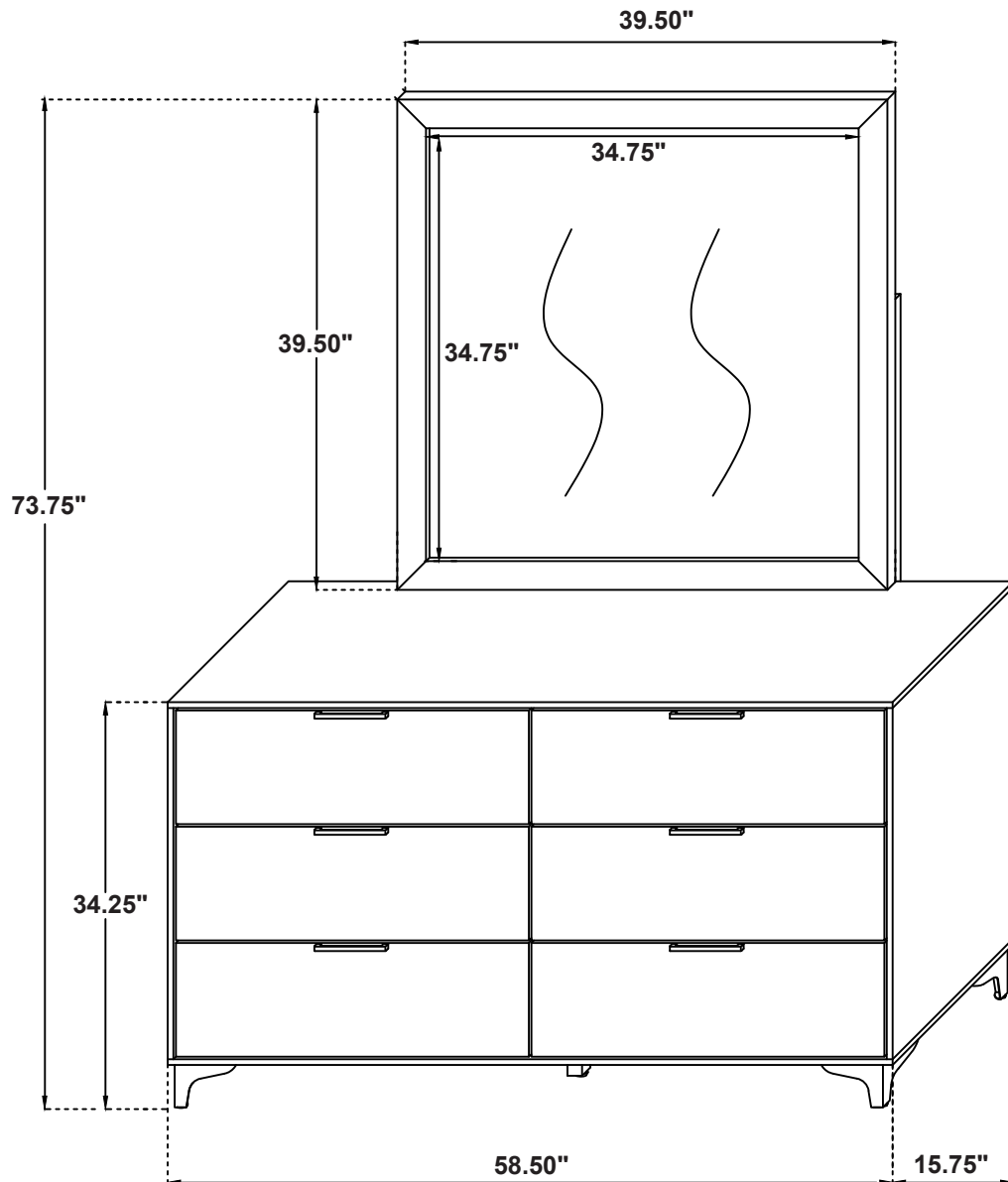

Note : Tolérance dimensionnelle / Dimension tolerance $\pm 5\%$

ASSEMBLY INSTRUCTIONS
COASTER FINE FURNITURE

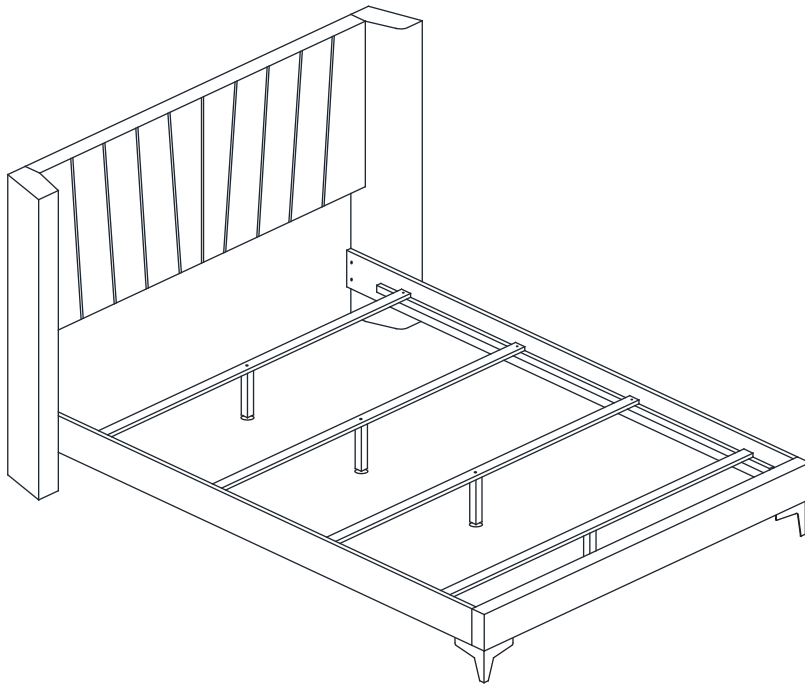

Fine Furniture for every stage of life

301161Q (B1&B2)
Queen Bed

ITEM: 301161Q (B1&B2)



ASSEMBLY INSTRUCTIONS

ASSEMBLY TIPS:

1. Remove hardware from box and sort by size.
2. Please check to see that all hardware and parts are present prior to start of assembly.
3. Please follow attached instructions in the same sequence as numbered to assure fast & easy assembly.



WARNING!

1. Don't attempt to repair or modify parts that are broken or defective. Please contact the store immediately.
2. This product is for home use only and not intended for commercial establishments.



ASSEMBLY TIME

30 MINUTES

PARTS IDENTIFICATION

B1 (BOX 1)

A	HEADBOARD PANEL		1PC	E	FOOTBOARD LEG		2PCS
B	LEFT HEADBOARD LEG (WITH "L" LABEL)		1PC	F	BED SLAT		4PCS
C	RIGHT HEADBOARD LEG (WITH "R" LABEL)		1PC	G	BED SLAT SUPPORT WITH LEVELER		4PCS
D	FOOTBOARD PANEL		1PC				

B2 (BOX 2)

H	LEFT BED RAIL (WITH "H" LABEL)		1PC	I	RIGHT BED RAIL (WITH "I" LABEL)		1PC
---	-----------------------------------	--	-----	---	------------------------------------	--	-----

NOTE:

Phillips head screw driver is required in the assembly process; however, manufacturer does not provided this item.

ITEM: 301161Q (B1&B2)



ASSEMBLY INSTRUCTIONS

ASSEMBLY TIPS:

1. Remove hardware from box and sort by size.
2. Please check to see that all hardware and parts are present prior to start of assembly.
3. Please follow attached instructions in the same sequence as numbered to assure fast & easy assembly.





WARNING!

1. Don't attempt to repair or modify parts that are broken or defective. Please contact the store immediately.
2. This product is for home use only and not intended for commercial establishments.

HARDWARE IDENTIFICATION

Z-B2 (BOX 2) - HARDWARE PACK IS LOCATED IN 301161Q (B1)

1	BOLT 1 (M8 x 20MM - RBW)		4PCS	7	BIG LOCK WASHER (5/16" x 13 Ø - RBW)		4PCS
2	BOLT 2 (M8 x 35MM - RBW)		4PCS	8	BIG FLAT WASHER (5/16" x 22 Ø - RBW)		4PCS
3	BOLT 3 (M6 x 15MM - RBW)		6PCS	9	WOOD DOWEL (M10Ø x 30MM)		4PCS
4	BOLT 4 (M6 x 35MM - RBW)		10PCS	10	FLAT HEAD SCREW (M4 x 32MM - RBW)		8PCS
5	SMALL LOCK WASHER (1/4" X 12 Ø - RBW)		6PCS	11	SMALL ALLEN WRENCH (M4 x 100MM - BLK)		1PC
6	SMALL FLAT WASHER (1/4" X 19 Ø - RBW)		6PCS	12	BIG ALLEN WRENCH (M5 x 65MM - BLK)		1PC

NOTE:

Phillips head screw driver is required in the assembly process; however, manufacturer does not provided this item.

ITEM: 301161Q (B1&B2)

ASSEMBLY INSTRUCTIONS

STEP 1

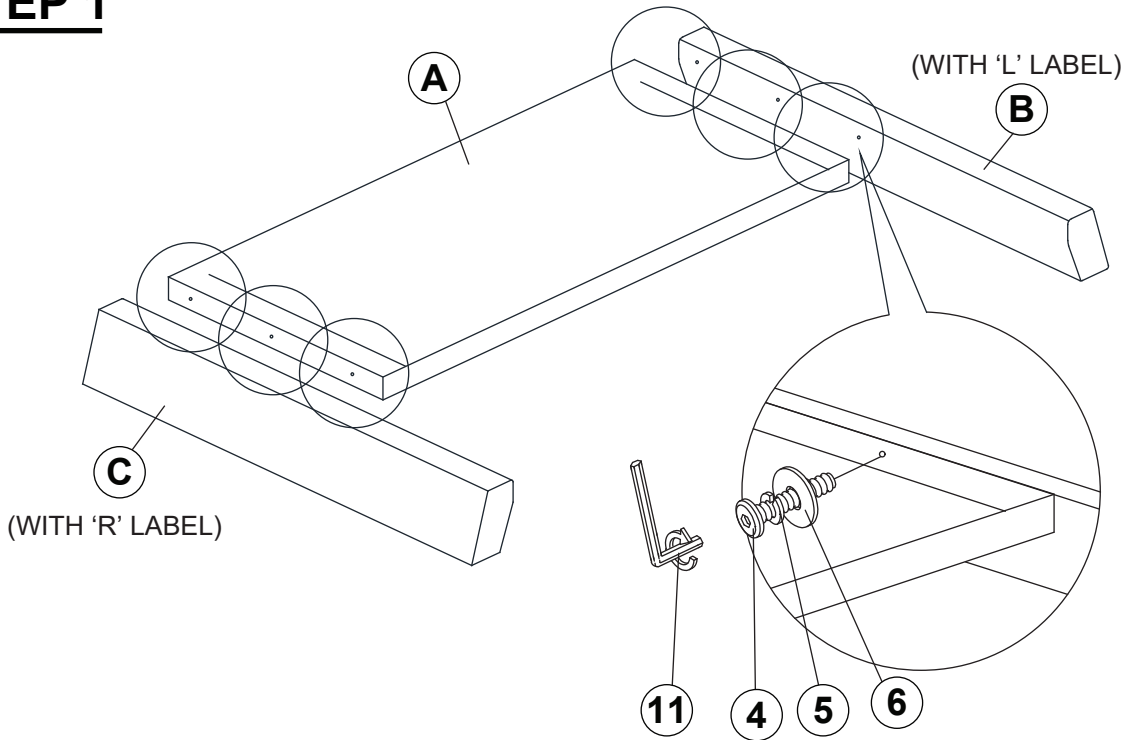

STEP 2

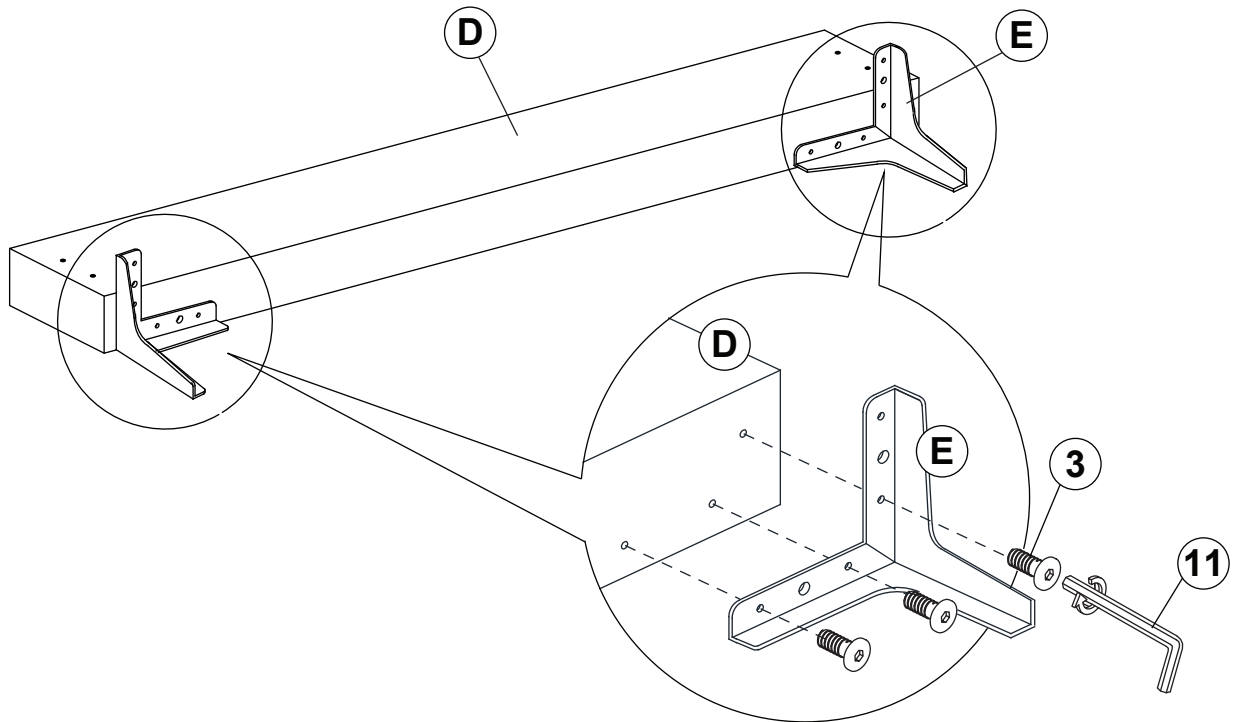

ITEM: 301161Q (B1&B2)



ASSEMBLY INSTRUCTIONS

STEP 3

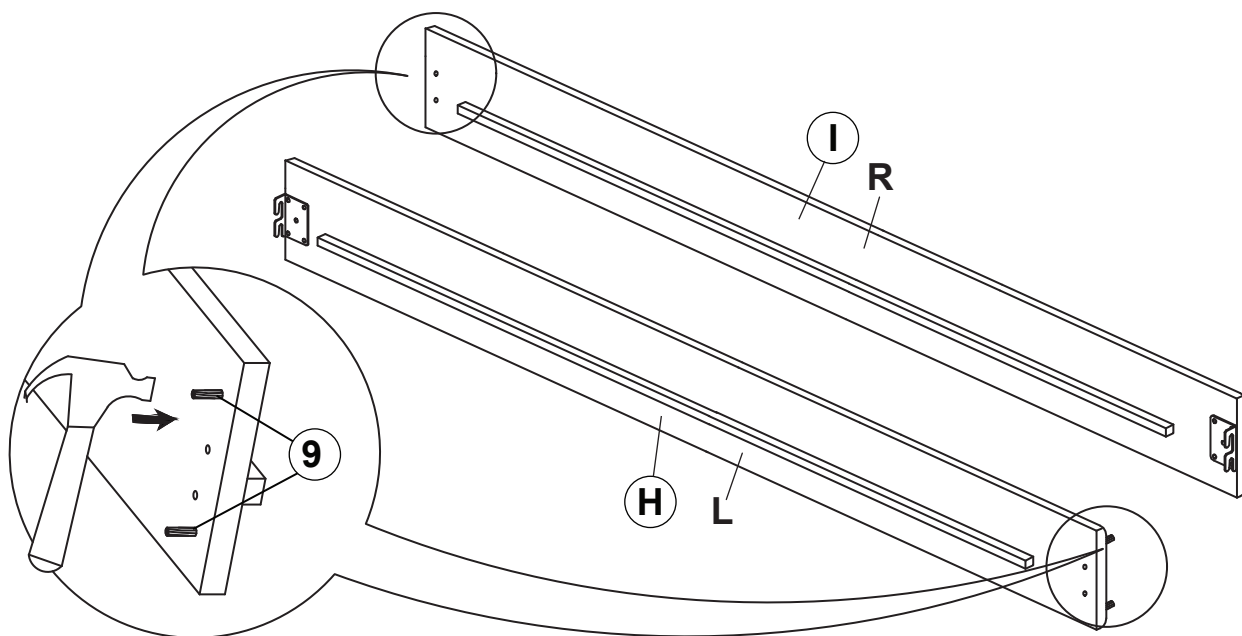

STEP 4

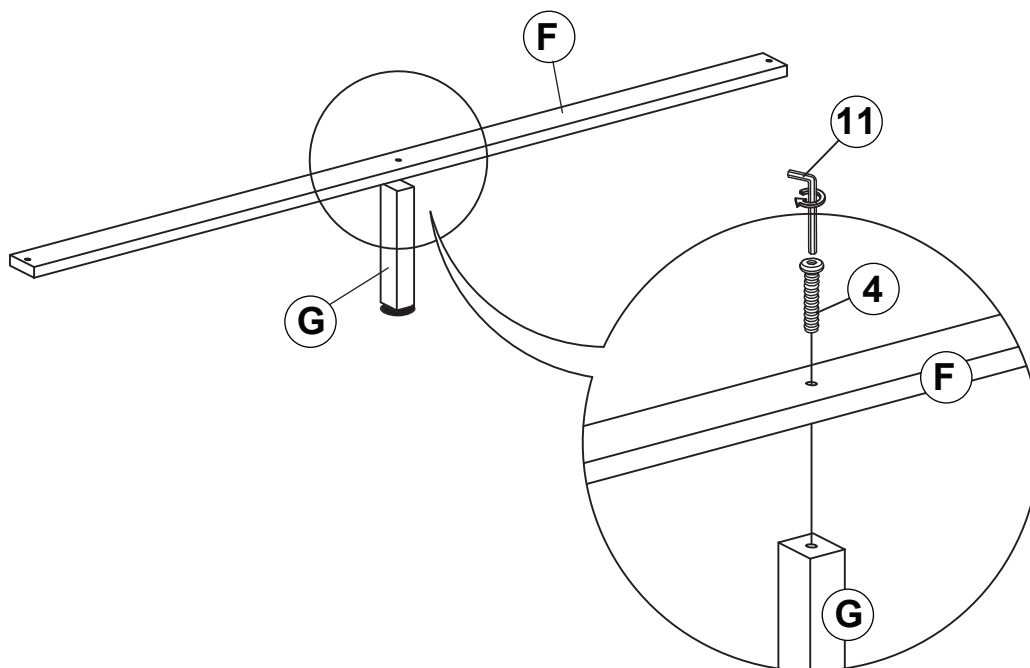

ITEM: 301161Q (B1&B2)



ASSEMBLY INSTRUCTIONS

STEP 5

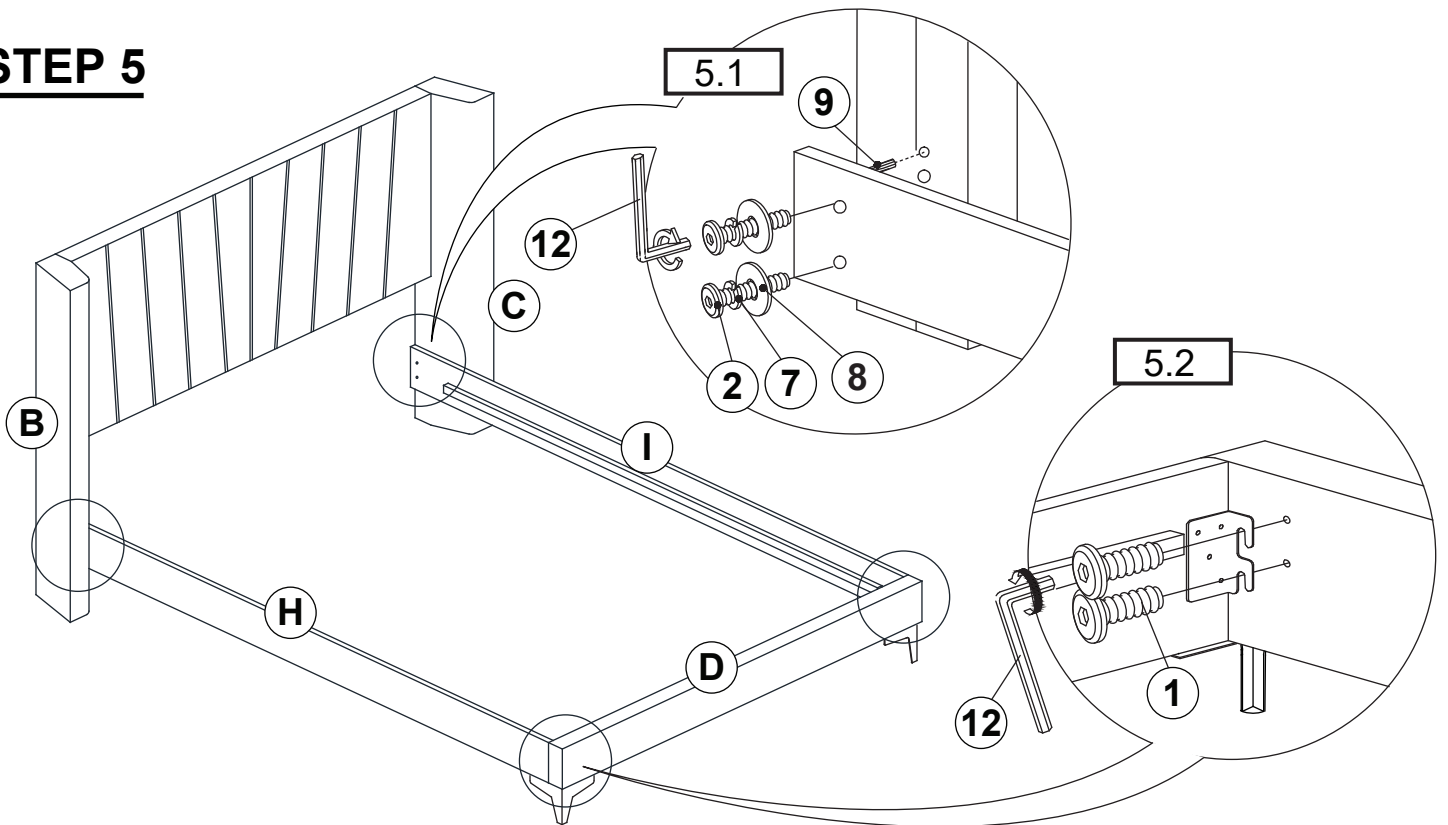

STEP 6 COMPLETE

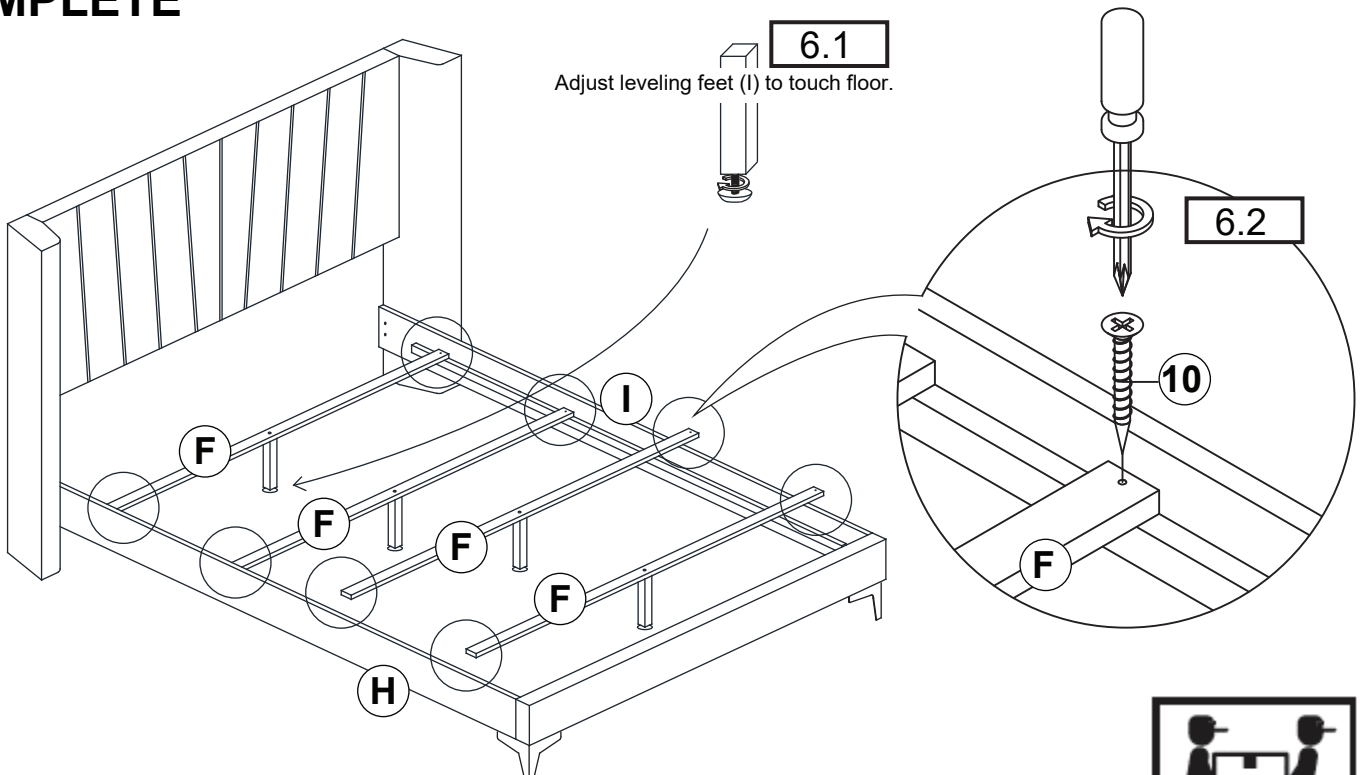

ITEM: 301161Q (B1&B2)



Inner size: 60.75"W X 81.25"D

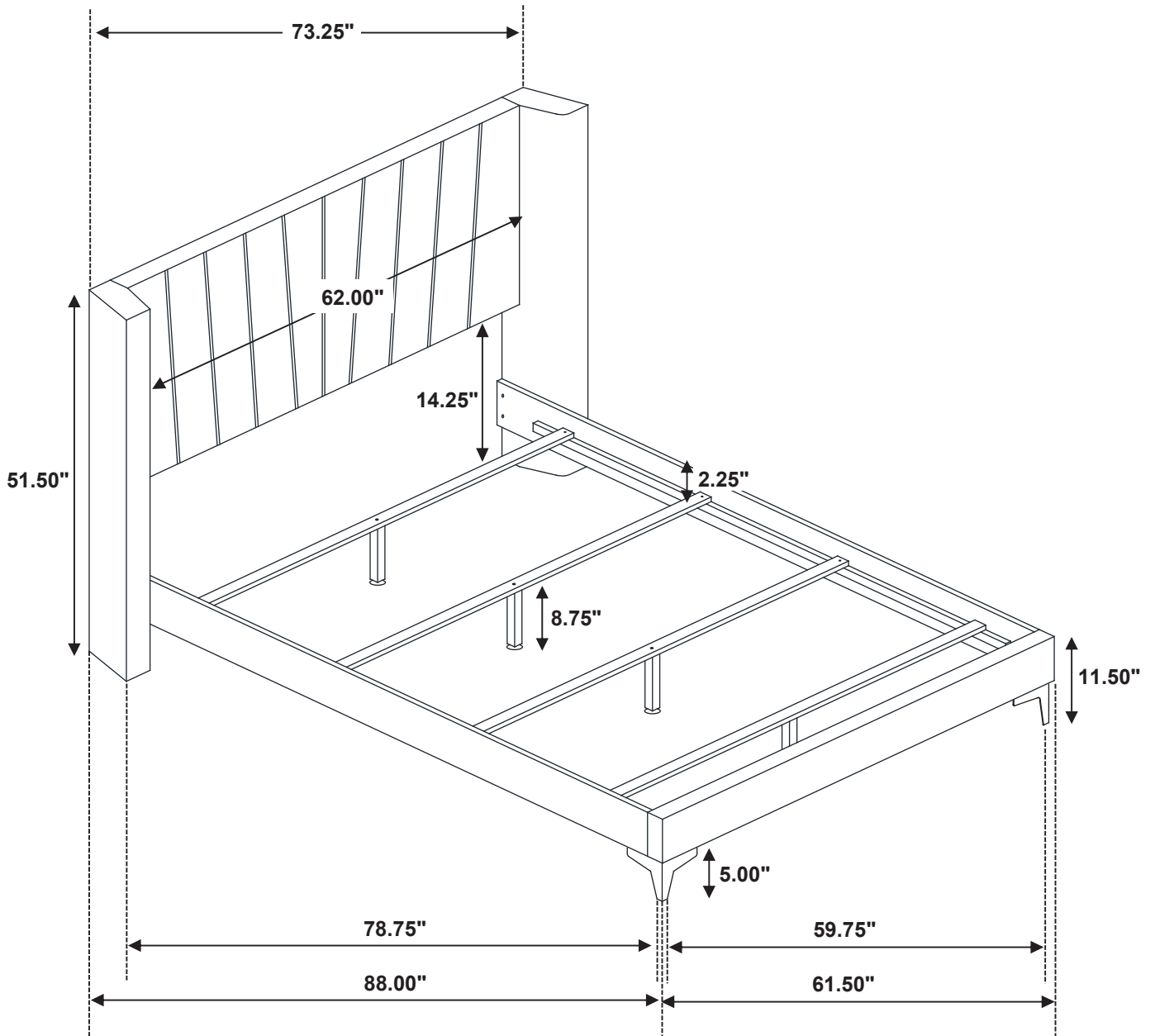

Note : Dimension tolerance $\pm 5\%$