

ASSEMBLY INSTRUCTIONS
COASTER FINE FURNITURE



Fine Furniture for every stage of life

306037CHKE(B1-B3)
Eastern King Bed

ITEM: 306037CHKE(B1-B3)



ASSEMBLY INSTRUCTIONS

ASSEMBLY TIPS:

1. Remove hardware from box and sort by size.
2. Please check to see that all hardware and parts are present prior to start of assembly.
3. Please follow attached instructions in the same sequence as numbered to assure fast & easy assembly.



WARNING!

1. Don't attempt to repair or modify parts that are broken or defective. Please contact the store immediately.
2. This product is for home use only and not intended for commercial establishments.



ASSEMBLY TIME

15 MINUTES

PARTS IDENTIFICATION

B1 (BOX 1)

A HEABOARD

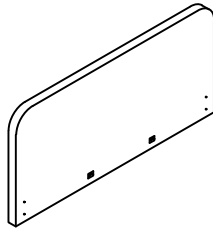

1PC

B2 (BOX 2)

B FOOTBOARD

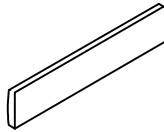

1PC

C LEFT BED RAIL

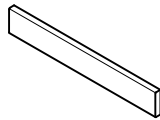

1PC

D RIGHT BED RAIL

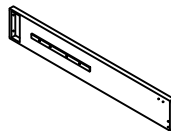

1PC

E LEFT GAS LIFT MECHANISM

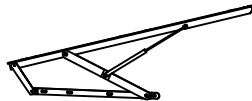

1PC

F RIGHT GAS LIFT MECHANISM

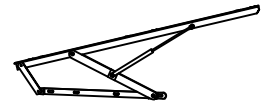

1PC

G CENTER SUPPORT RAIL

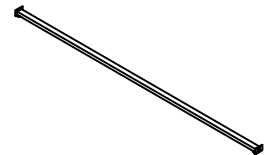

2PCS

H BED SLAT SUPPORT WITH LEVELER

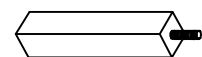

4PCS

B3 (BOX 3)

I FRONT TOP STORAGE PANEL

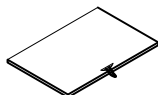

1PC

K FRONT BOTTOM STORAGE PANEL

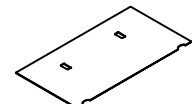

1PC

J BACK TOP STORAGE PANEL

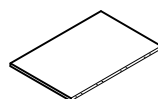

1PC

L BACK BOTTOM STORAGE PANEL

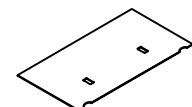

1PC

ITEM: 306037CHKE(B1-B3)



ASSEMBLY INSTRUCTIONS

ASSEMBLY TIPS:

1. Remove hardware from box and sort by size.
2. Please check to see that all hardware and parts are present prior to start of assembly.
3. Please follow attached instructions in the same sequence as numbered to assure fast & easy assembly.













WARNING!



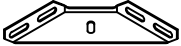

1. Don't attempt to repair or modify parts that are broken or defective. Please contact the store immediately.
2. This product is for home use only and not intended for commercial establishments.

HARDWARE IDENTIFICATION

Z-B2(BOX2) - HARDWARE PACK IS LOCATED IN 306037CHKE(B2)

1	THREADED BOLT (Ø5/16" x 90mm - BLK)		4PCS	7	HEX NUT (Ø5/16" - BLK)		4PCS
2	LONG BOLT (Ø5/16" x 50mm - BLK)		8PCS	8	WRENCH (14 x 90mm - BLK)		1PC
3	MEDIUM BOLT (Ø5/16" x 35mm - BLK)		16PCS	9	ALLEN KEY (M5 x 75 x 32mm - BLK)		1PC
4	SHORT BOLT (Ø5/16" x 25mm - BLK)		12PCS	10	METAL CLEAT (90 x 45 x 45 x 3mm - BLK)		2PCS
5	FLAT WASHER (Ø5/16"x 19mm - BLK)		40PCS	11	METAL BRACKET (180 x 180 x 18mm - BLK)		2PCS
6	LOCK WASHER (Ø5/16" x 2mm - BLK)		40PCS				

Z-B3(BOX3) - HARDWARE PACK IS LOCATED IN 306037CHKE(B3)

12	BOLT (Ø5/16" x 50mm - BLK)		8PCS	14	LOCK WASHER (Ø5/16"x 2mm - BLK)		8PCS
13	FLAT WASHER (Ø5/16"x 19mm - BLK)		8PCS	15	ALLEN KEY (M5 x 75 x 32mm - BLK)		1PC

NOTE:

Phillips head screw driver is required in the assembly process; however, manufacturer does not provide this item.

ITEM: 306037CHKE(B1-B3)

ASSEMBLY INSTRUCTIONS

STEP 1

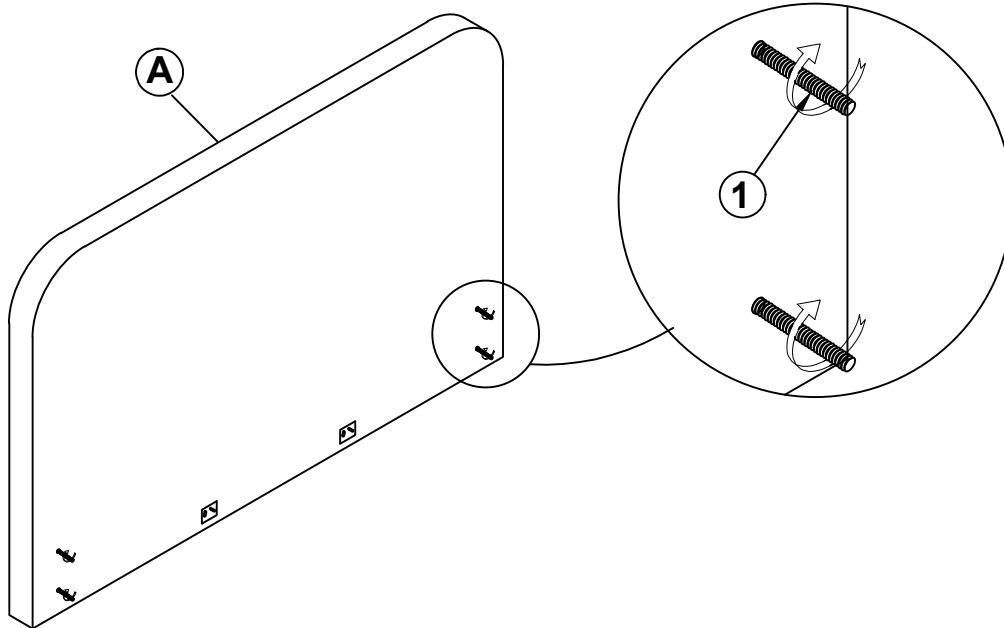

STEP 2

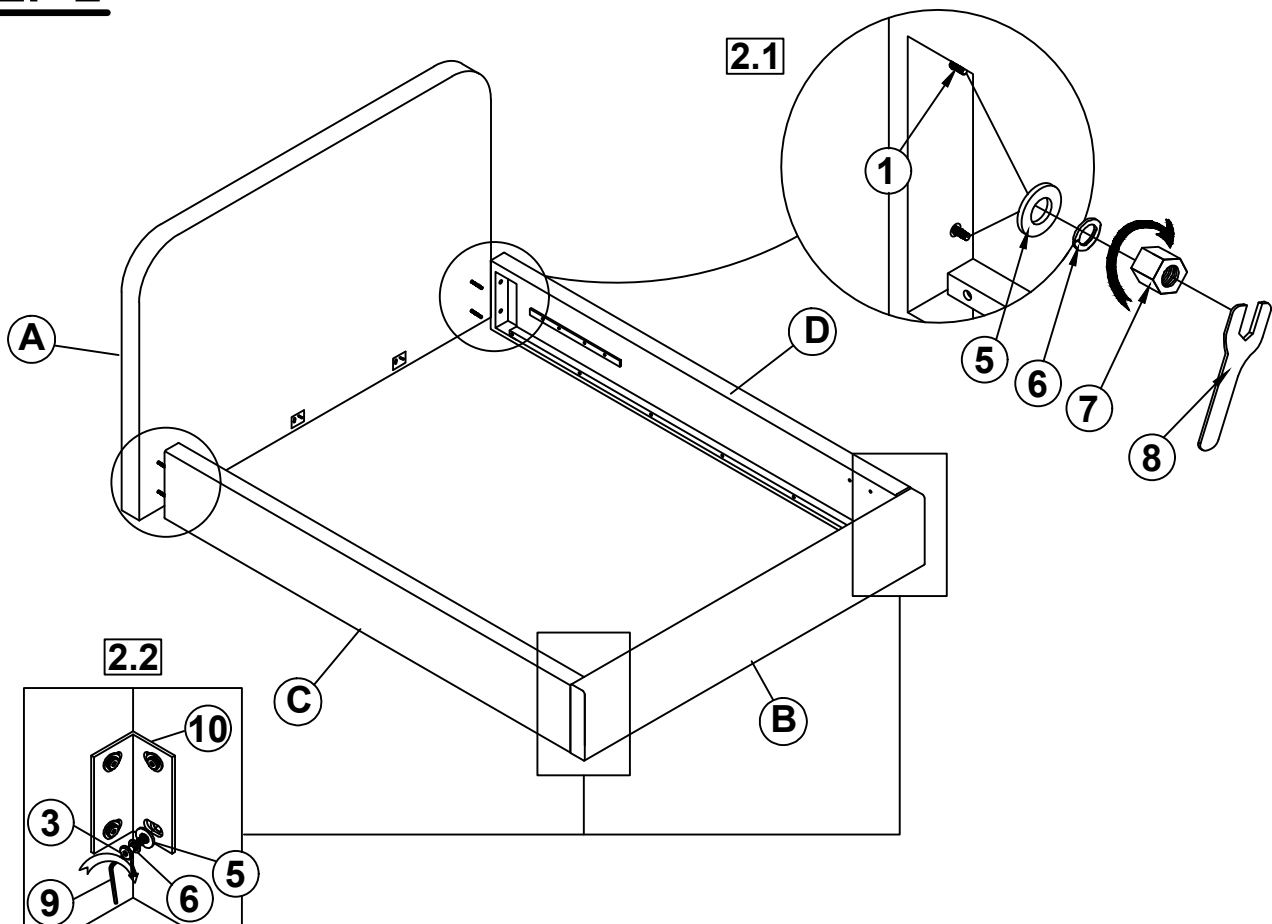

ITEM: 306037CHKE(B1-B3)

ASSEMBLY INSTRUCTIONS



STEP 3

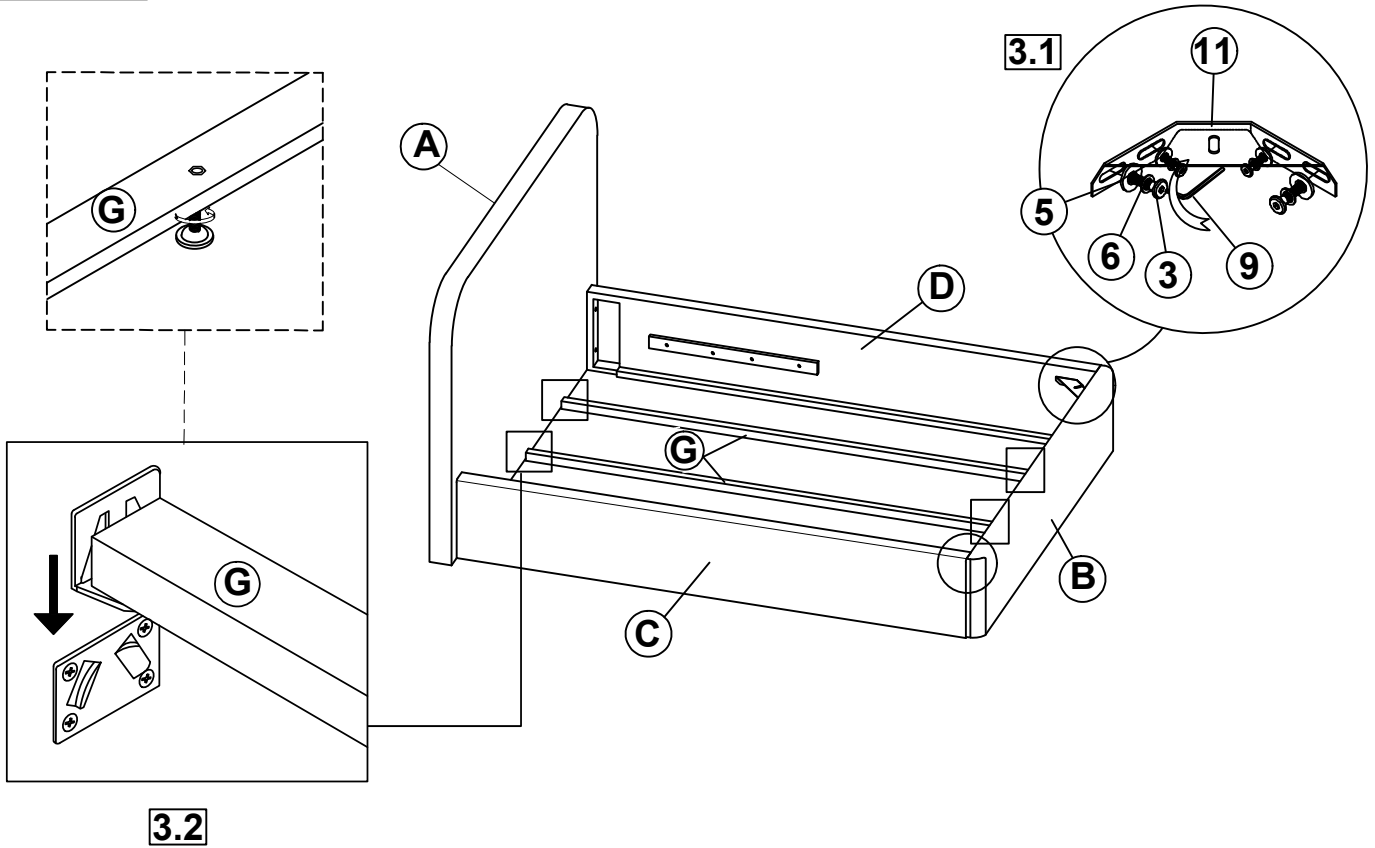

STEP 4

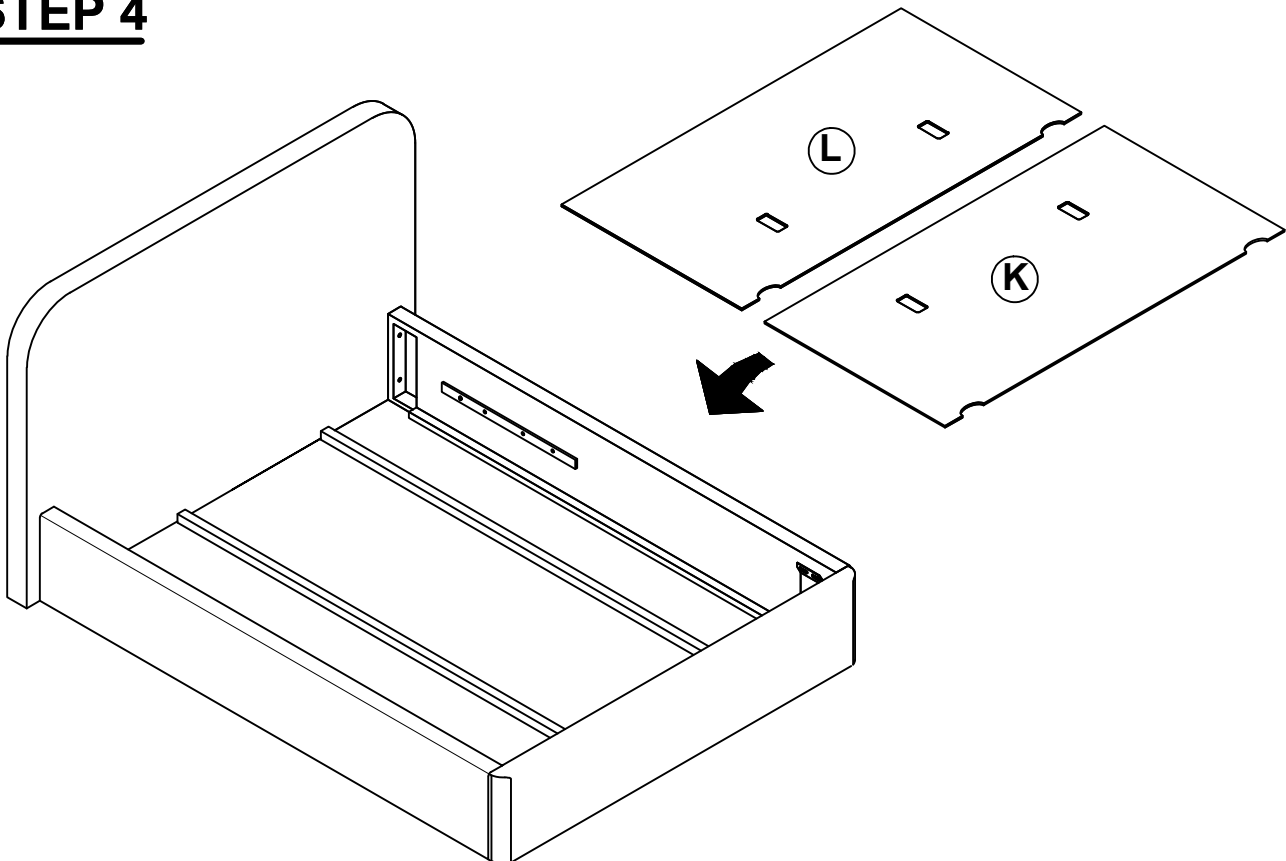

ITEM: 306037CHKE(B1-B3)

ASSEMBLY INSTRUCTIONS

STEP 5

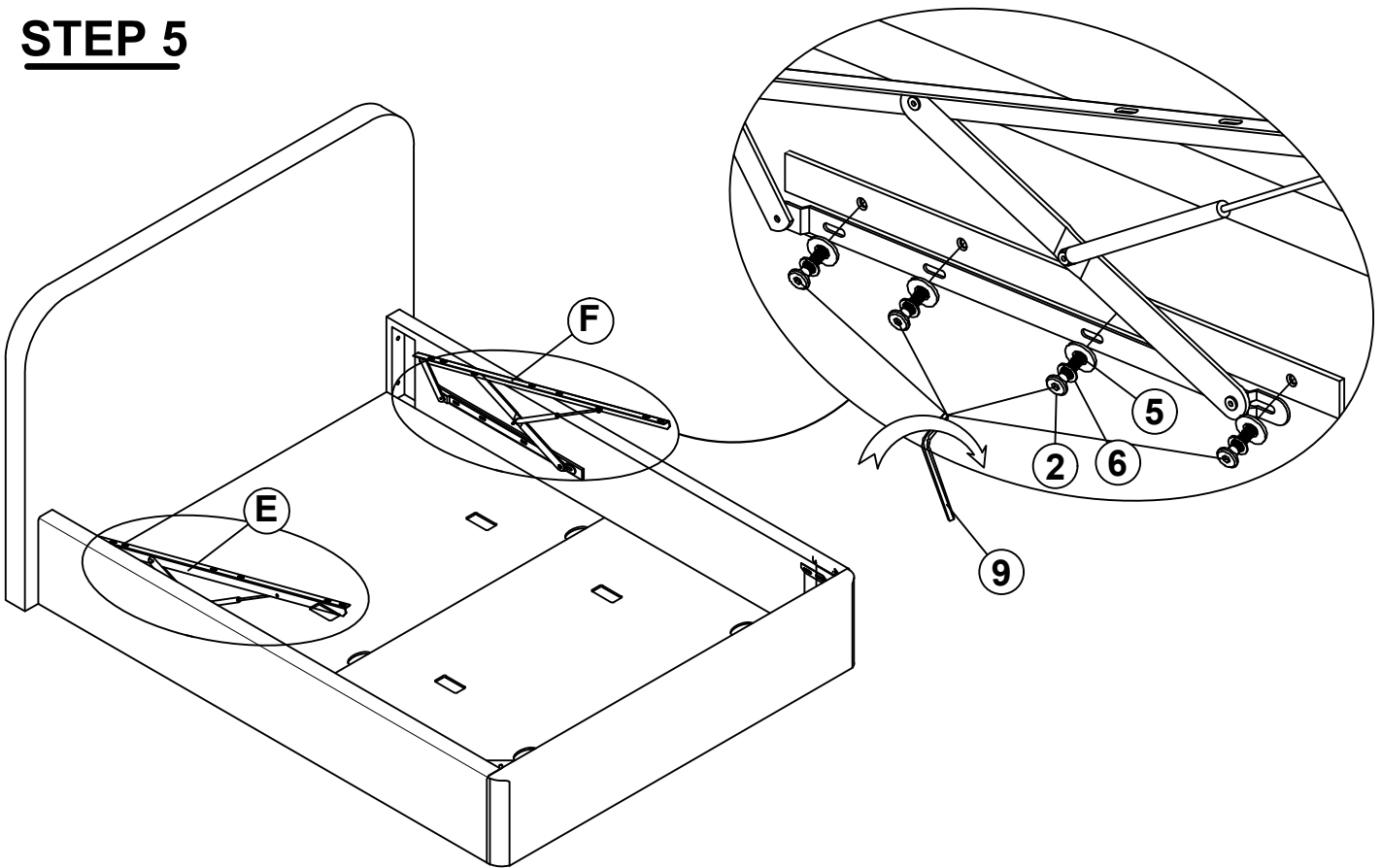

STEP 6

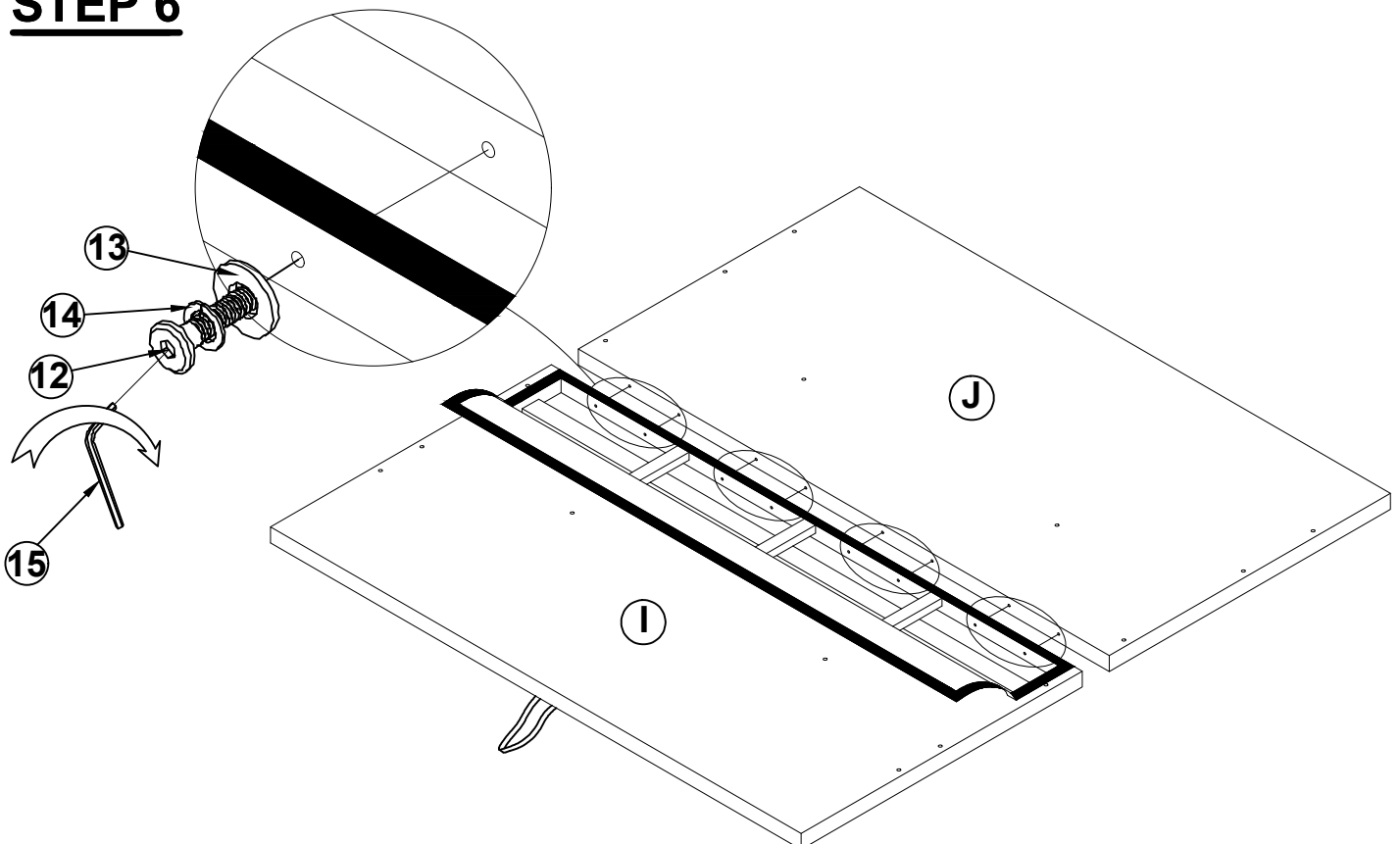

ITEM: 306037CHKE(B1-B3)

ASSEMBLY INSTRUCTIONS

STEP 7

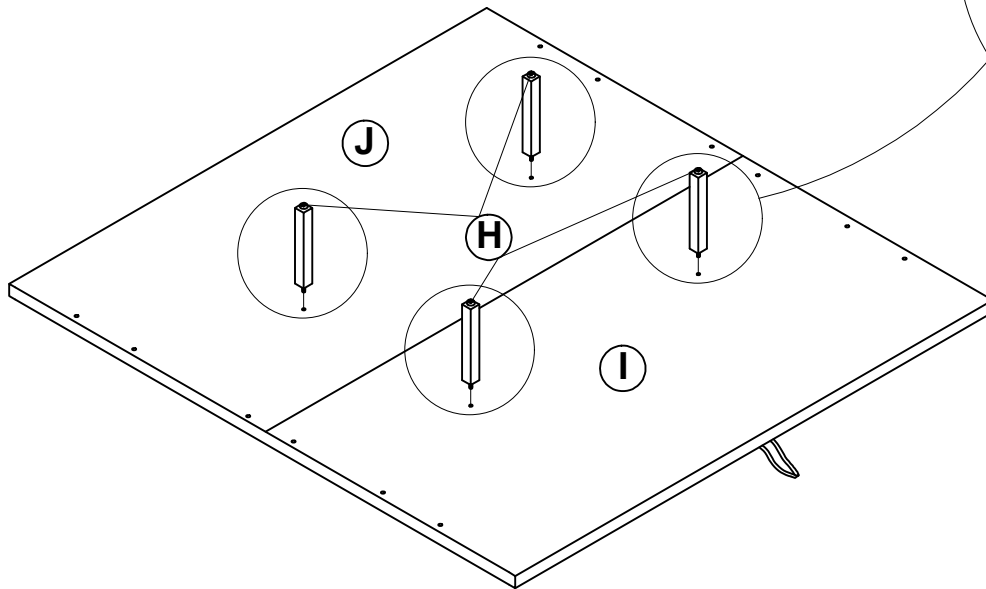

STEP 8

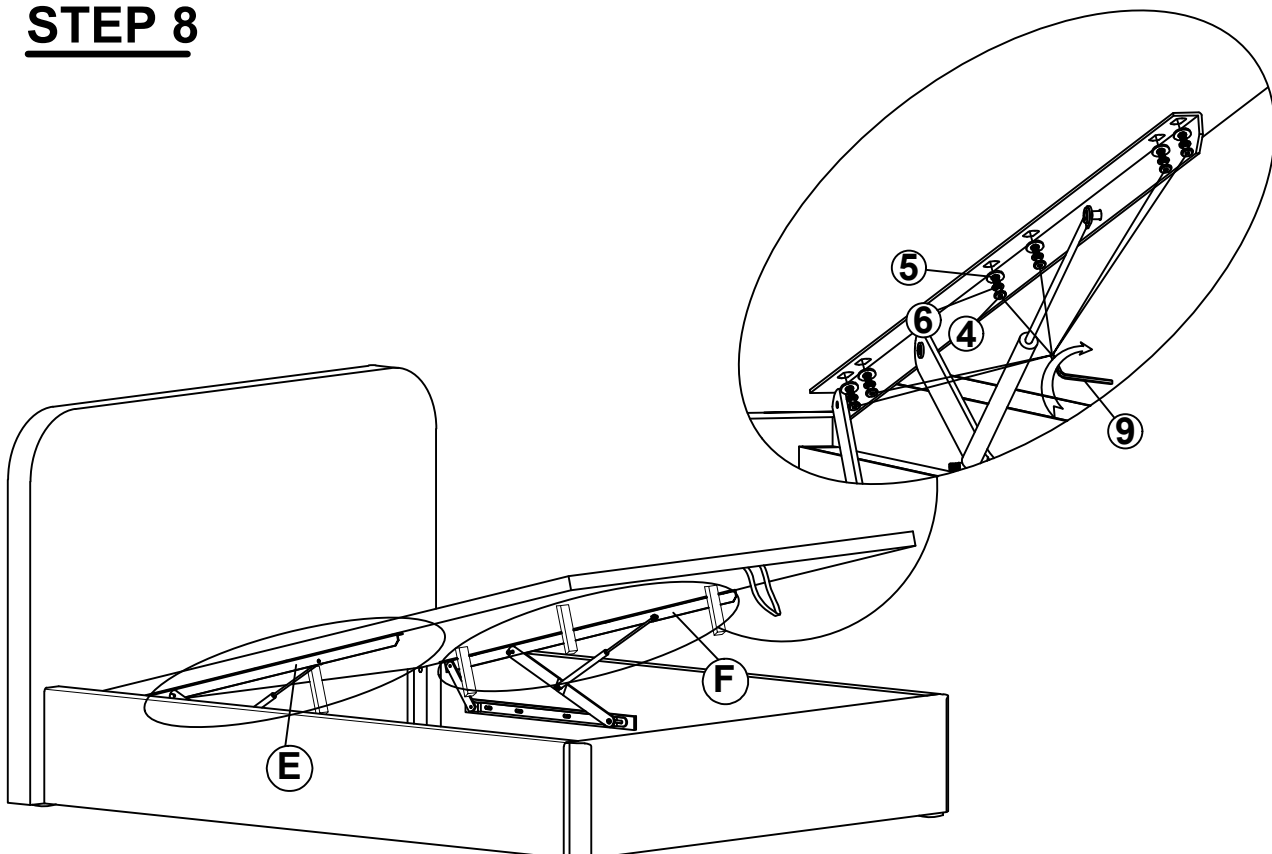

ITEM: **306037CHKE(B1-B3)**

ASSEMBLY INSTRUCTIONS

STEP 9

COMPLETE

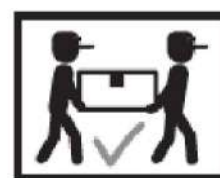
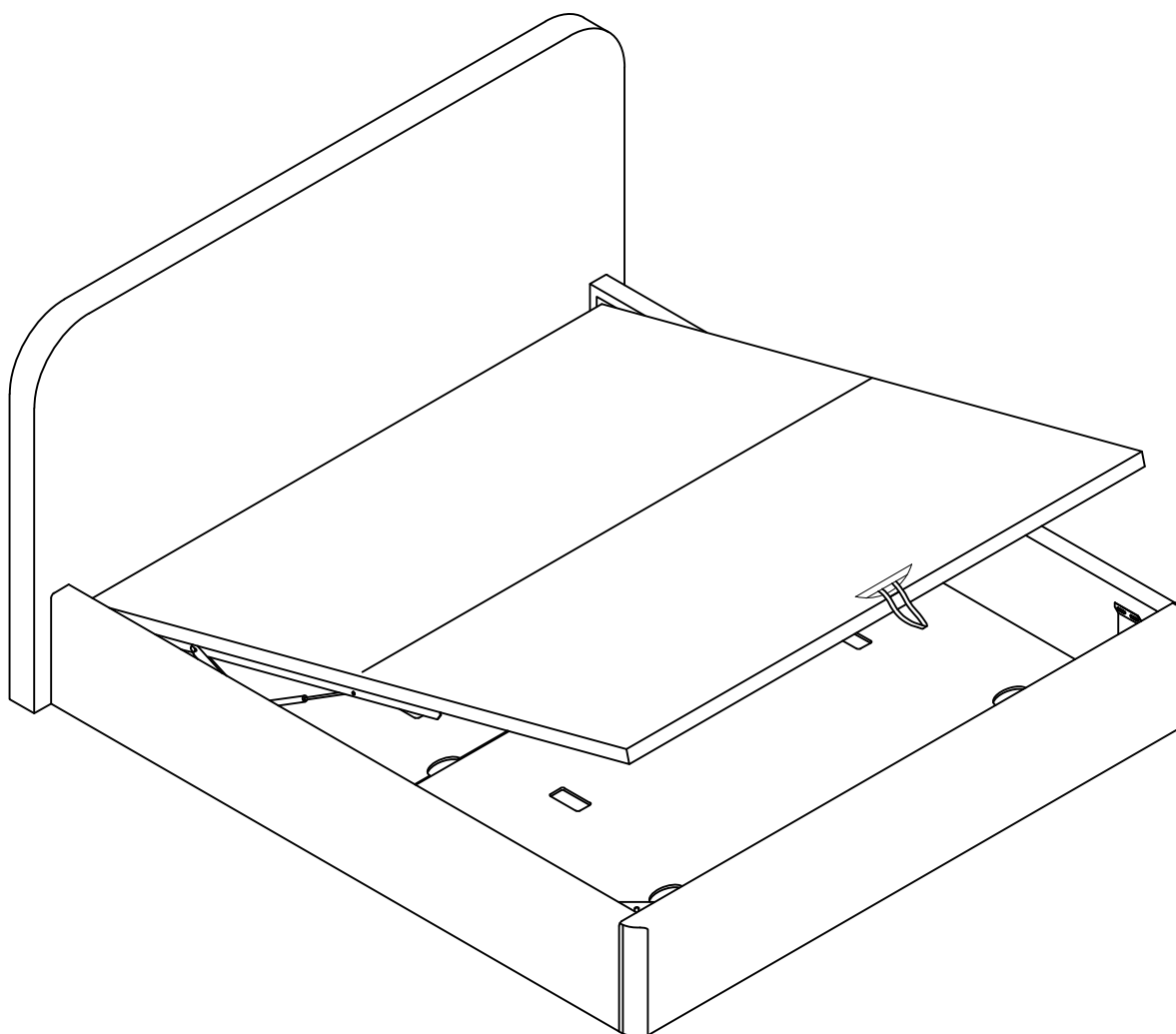

ITEM: **306037CHKE(B1-B3)**



Inner Size: 77.00"W X 81.00"D
Inner Storage Size: 77.00"W X 81.00"D

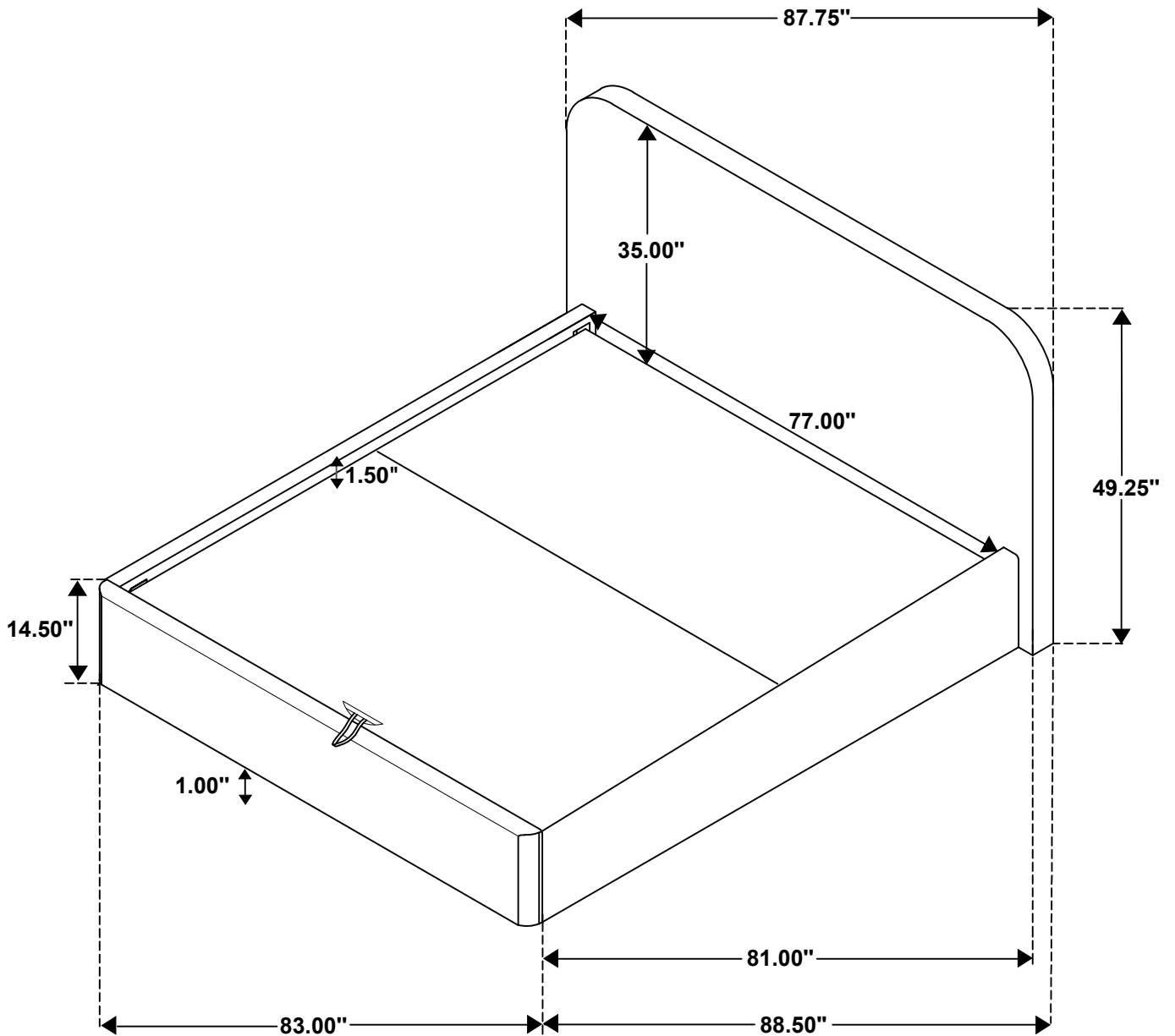

Note: Dimension tolerance $\pm 5\%$