

ASSEMBLY INSTRUCTIONS
COASTER FINE FURNITURE

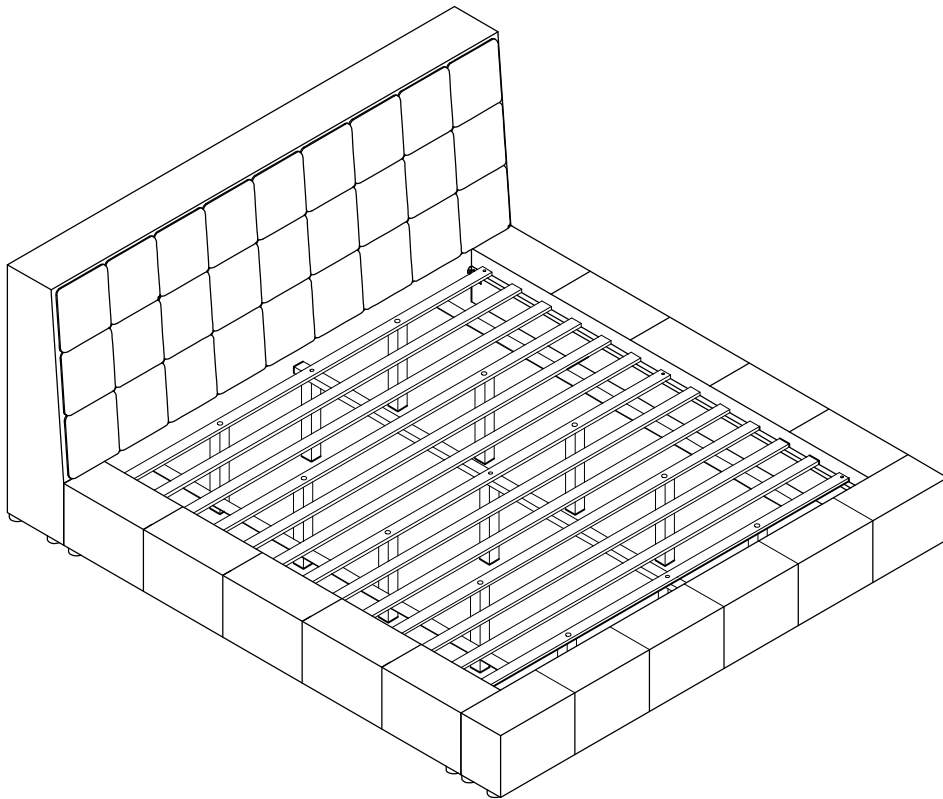

Fine Furniture for every stage of life

315948CRMKW(B1&B2)
California King Bed

ITEM: 315948CRMKW(B1&B2)

ASSEMBLY INSTRUCTIONS

ASSEMBLY TIPS:

1. Remove hardware from box and sort by size.
2. Please check to see that all hardware and parts are present prior to start of assembly.
3. Please follow attached instructions in the same sequence as numbered to assure fast & easy assembly.



WARNING!

1. Don't attempt to repair or modify parts that are broken or defective. Please contact the store immediately.
2. This product is for home use only and not intended for commercial establishments.

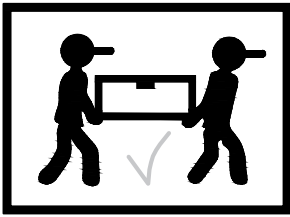

ASSEMBLY TIME

30 MINUTES

PARTS IDENTIFICATION

B1 (BOX 1)

A HEADBOARD

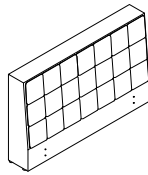

1PC

G ADAPTER



1 PC

B2 (BOX 2)

B FOOTBOARD

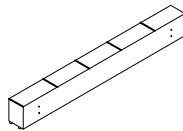

1PC

C BED RAIL

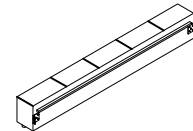

2PCS

D CENTER RAIL

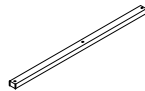

1PC

E CENTER RAIL SUPPORT WITH LEVELER



3PCS

F ROLL SLATS (13 PCS)

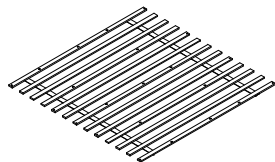

1 SET

H BED SLAT SUPPORT WITH LEVELER

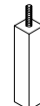

10PCS

ITEM: 315948CRMKW(B1&B2)

ASSEMBLY INSTRUCTIONS

ASSEMBLY TIPS:

1. Remove hardware from box and sort by size.
2. Please check to see that all hardware and parts are present prior to start of assembly.
3. Please follow attached instructions in the same sequence as numbered to assure fast & easy assembly.







WARNING!

1. Don't attempt to repair or modify parts that are broken or defective. Please contact the store immediately.
2. This product is for home use only and not intended for commercial establishments.

HARDWARE IDENTIFICATION

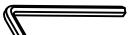
Z-B2 (BOX 2) - HARDWARE PACK IS LOCATED IN 315948CRMKW(B2)

1	BOLT (Ø5/16" x 35mm- RBW)		8PCS	2	FLAT WASHER (Ø5/16"x19mm - RBW)		8PCS
3	LOCK WASHER (Ø5/16" - RBW)		8PCS	4	ALLEN WRENCH (5mm - RBW)		1PC
5	FLAT HEAD SCREW (M4 x 35mm - RBW)		8PCS				

NOTE:

Phillips head screw driver is required in the assembly process; however, manufacturer does not provide this item.

ITEM: 315948CRMKW(B1&B2)

ASSEMBLY INSTRUCTIONS



STEP 1

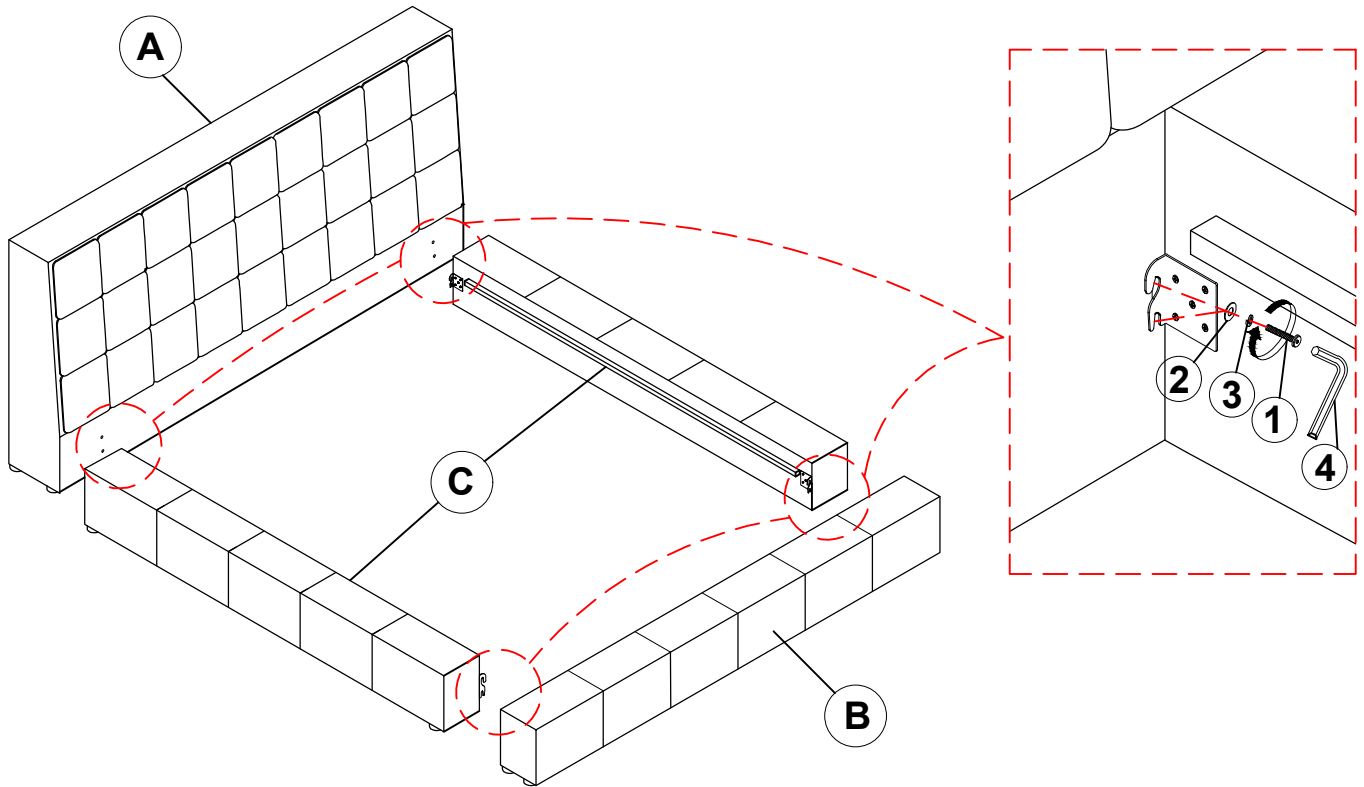

STEP 2

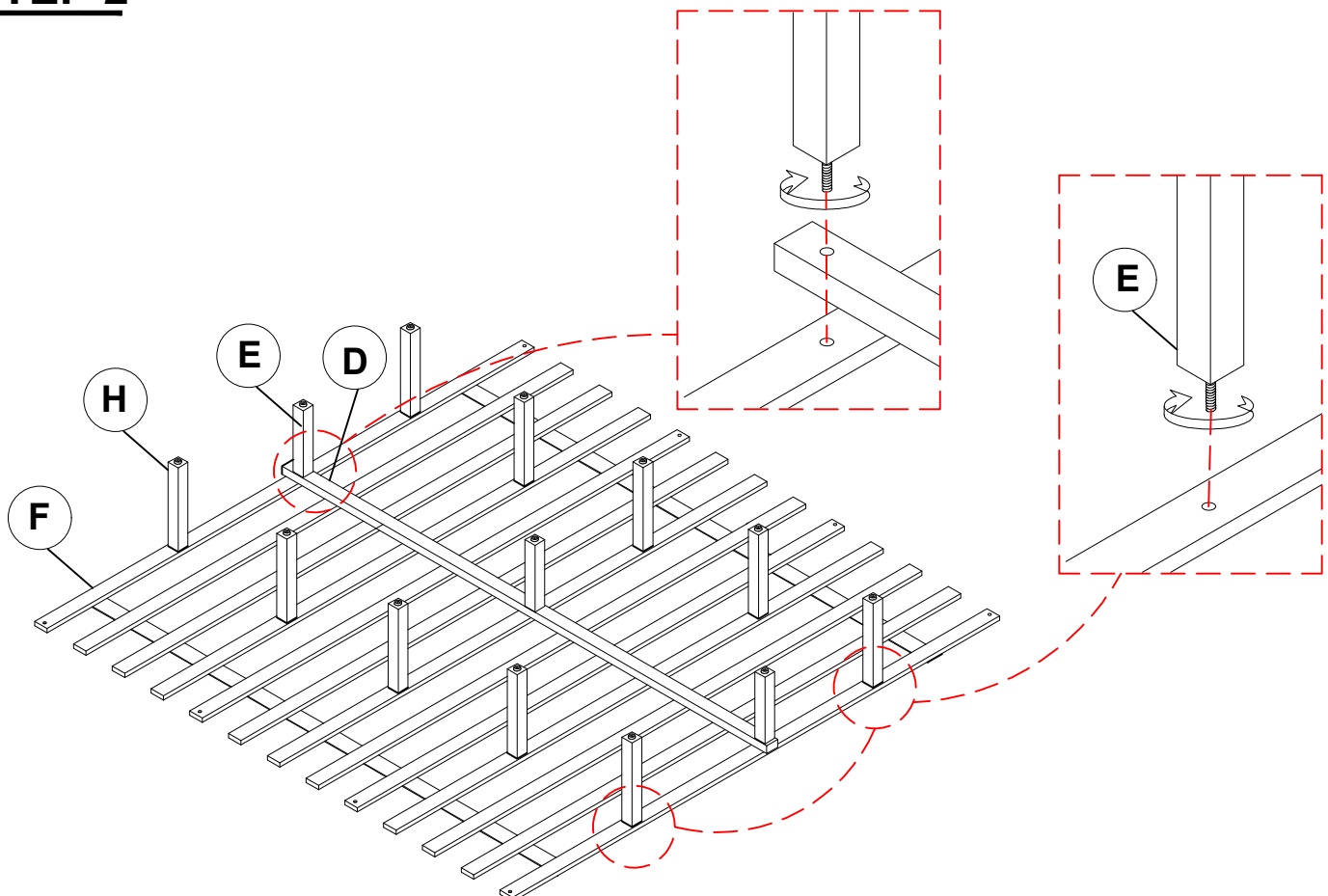

ITEM: 315948CRMKW(B1&B2)

ASSEMBLY INSTRUCTIONS

STEP 3

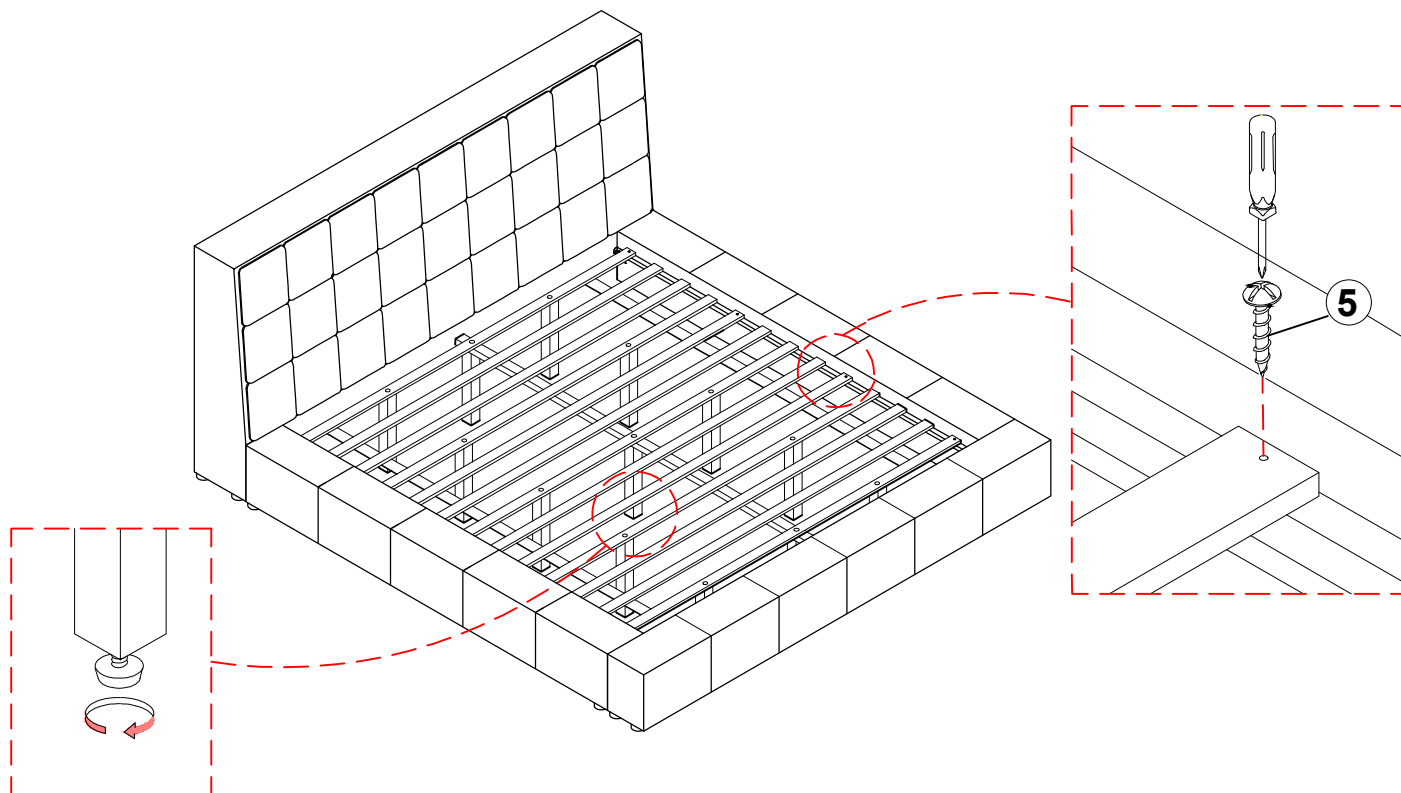

STEP 4 COMPLETE

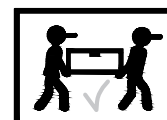
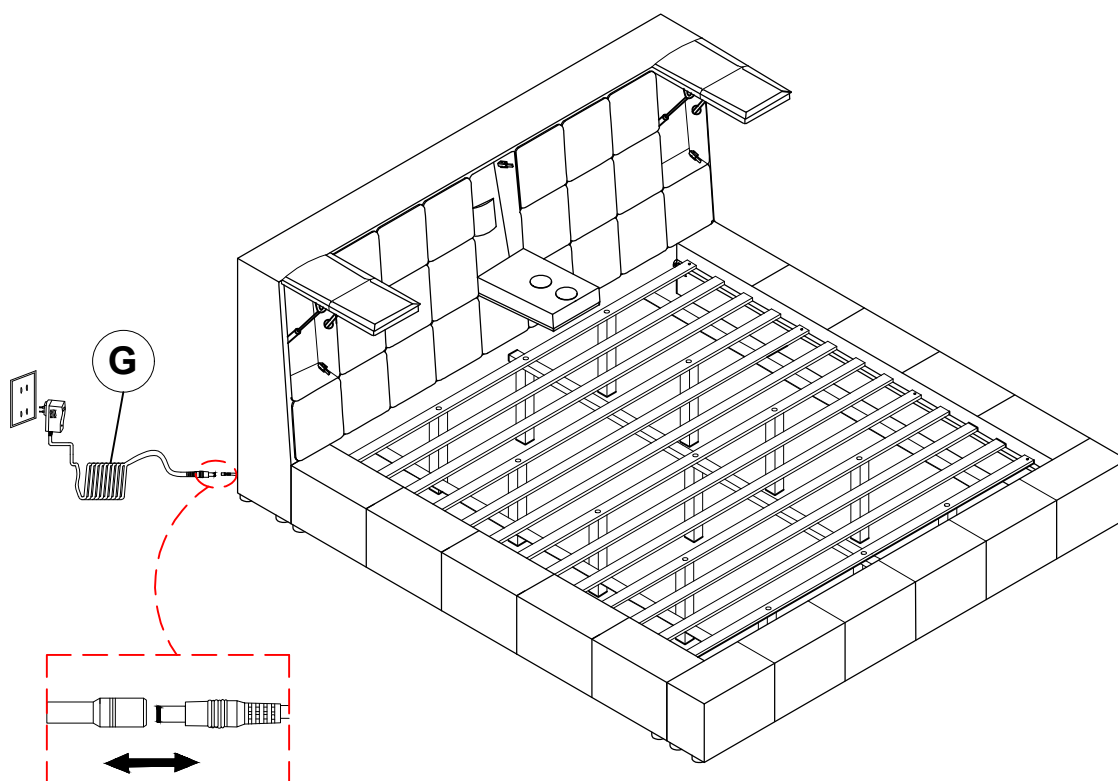

ITEM: **315948CRMKW(B1&B2)**



Inner size: 73.00"W x 85.25"D

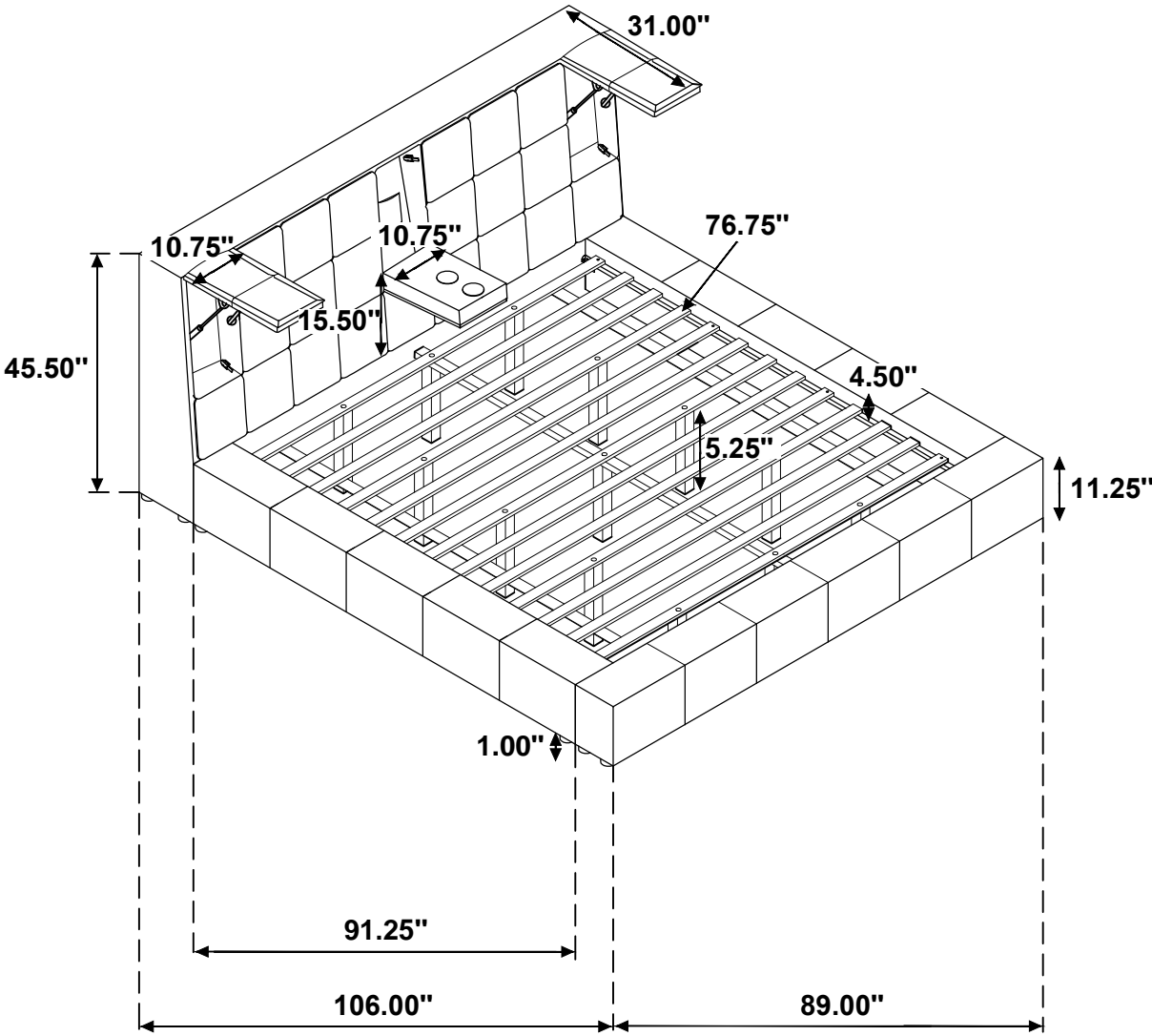

Note: Dimension tolerance $\pm 5\%$