



*ASSEMBLY INSTRUCTIONS  
COASTER FINE FURNITURE*



*Fine Furniture for every stage of life*

**500359(B1&B2)**  
**Sleeper Sectional**

# ITEM: 500359(B1 & B2)



## ASSEMBLY INSTRUCTIONS

### ASSEMBLY TIPS:

1. Remove hardware from box and sort by size.
2. Please check to see that all hardware and parts are present prior to start of assembly.
3. Please follow attached instructions in the same sequence as numbered to assure fast & easy assembly.



### WARNING!

1. Don't attempt to repair or modify parts that are broken or defective. Please contact the store immediately.
2. This product is for home use only and not intended for commercial establishments.



ASSEMBLY TIME

15 MINUTES

## PARTS IDENTIFICATION

### B1(BOX 1)

A	LOVESEAT BACK FRAME		1PC
B	LAF LOVESEAT SEAT		1PC
E	BACK CUSHION		2PCS
F	PILLOW		1PC
G	LEG		2PCS
H	FOOT		4PCS
I	CASTER WITH SCREW		4SETS

### B2(BOX 2)

C	CHAISE BACK FRAME		1PC
D	RAF CHAISE SEAT		1PC
E	BACK CUSHION		1PC
F	PILLOW		1PC
G	LEG		5PCS
H	FOOT		2PCS

# ITEM: 500359(B1 & B2)



## ASSEMBLY INSTRUCTIONS

### ASSEMBLY TIPS:

1. Remove hardware from box and sort by size.
2. Please check to see that all hardware and parts are present prior to start of assembly.
3. Please follow attached instructions in the same sequence as numbered to assure fast & easy assembly.



### WARNING!

1. Don't attempt to repair or modify parts that are broken or defective. Please contact the store immediately.
2. This product is for home use only and not intended for commercial establishments.

## HARDWARE IDENTIFICATION

### Z-B1(BOX 1) - HARDWARE PACK IS LOCATED IN 500359(B1)

1	<b>PAN HEAD SCREW</b> (M8 x 45mm - BLK)		8PCS
2	<b>CONNECTING METAL</b> (6" x 1-1/4" x 3/8" - BRW)		2PCS

### Z-B2(BOX 2) - HARDWARE PACK IS LOCATED IN 500359(B2)

1	<b>PAN HEAD SCREW</b> (M8 x 45mm - BLK)		12PCS
2	<b>CONNECTING METAL</b> (6" x 1-1/4" x 3/8" - BRW)		2PCS

### NOTE:

Phillips head screw driver is required in the assembly process; however, manufacturer does not provide this item.

ITEM: **500359(B1 & B2)**  
**ASSEMBLY INSTRUCTIONS**  
**STEP 1**

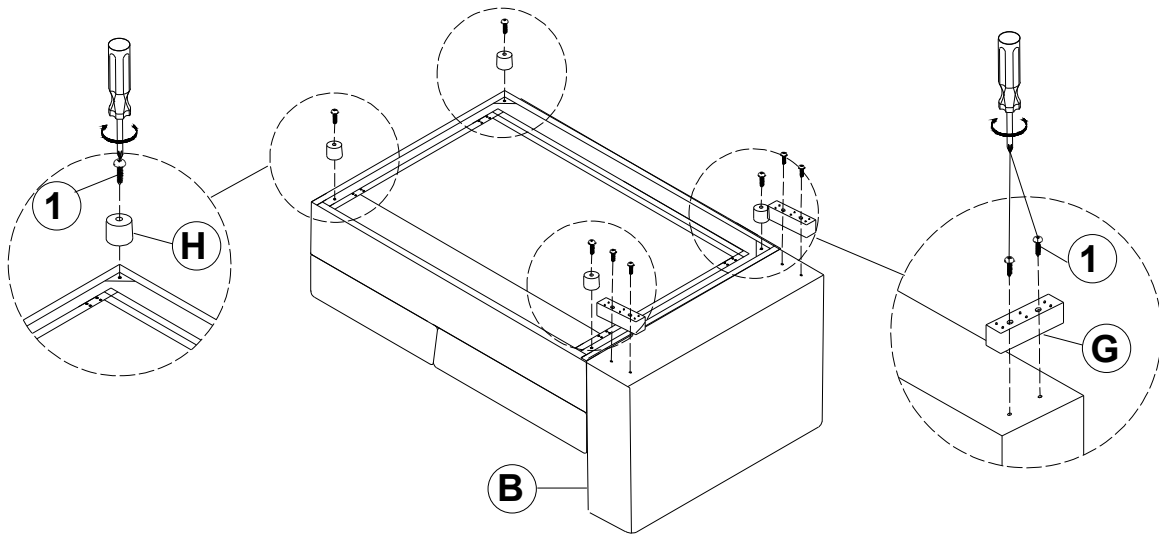

**STEP 2**

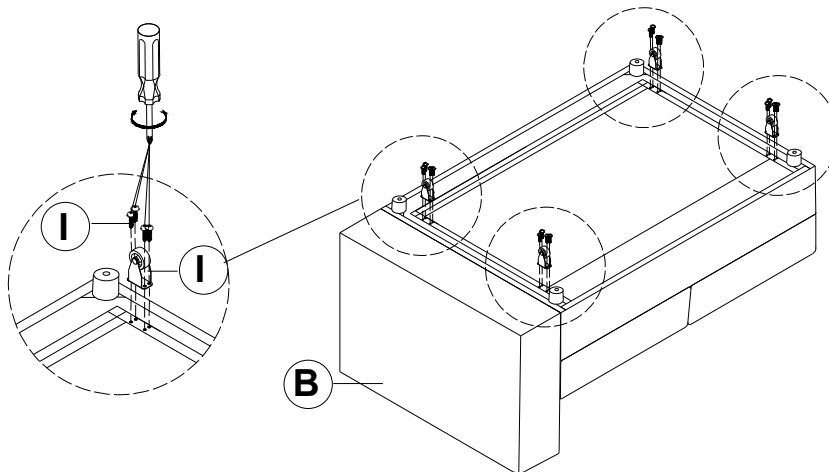

**STEP 3**

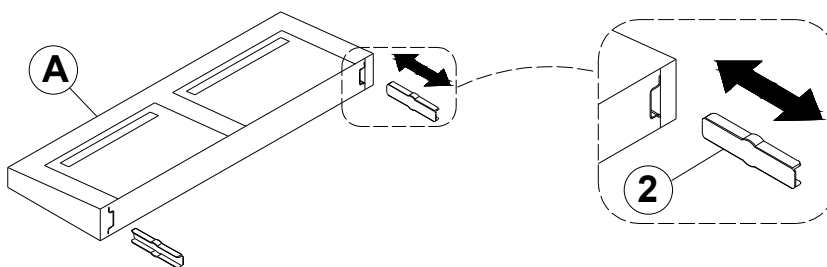

ITEM: **500359(B1 & B2)**  
**ASSEMBLY INSTRUCTIONS**  
**STEP 4**

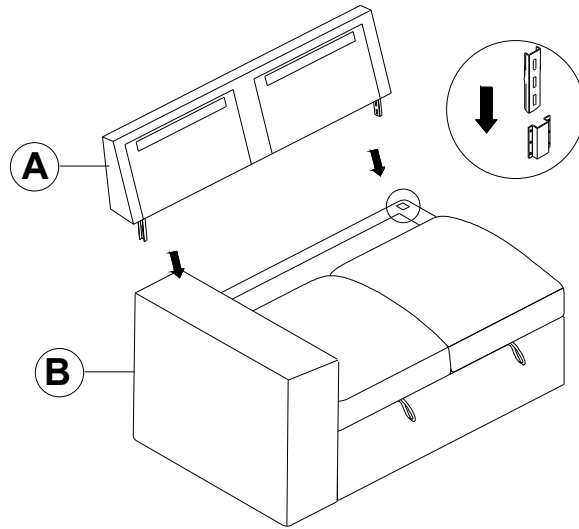

**STEP 5**

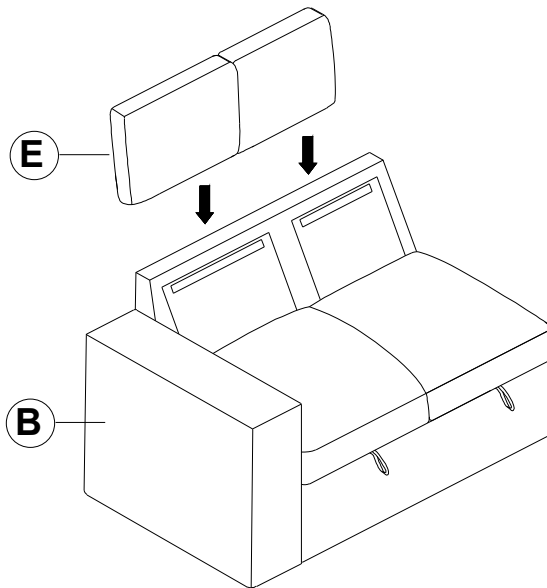

**STEP 6**

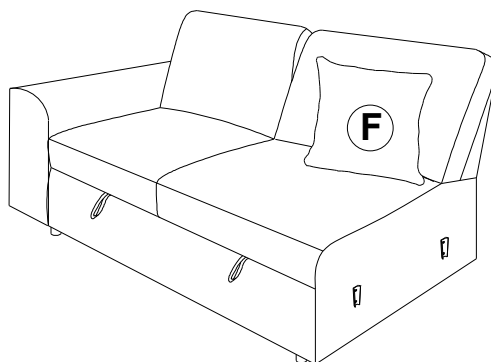

# ITEM: 500359(B1 & B2)

## ASSEMBLY INSTRUCTIONS



### STEP 7

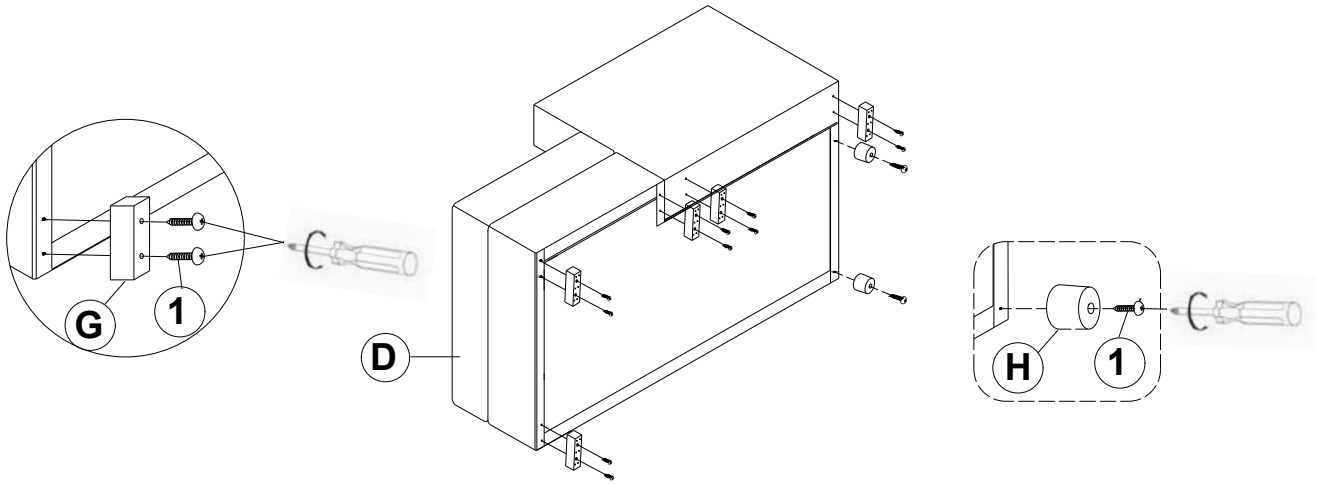

### STEP 8

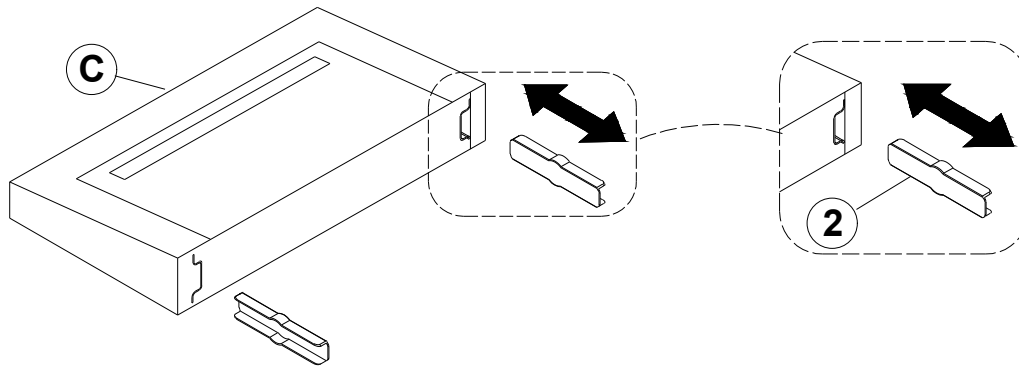

### STEP 9

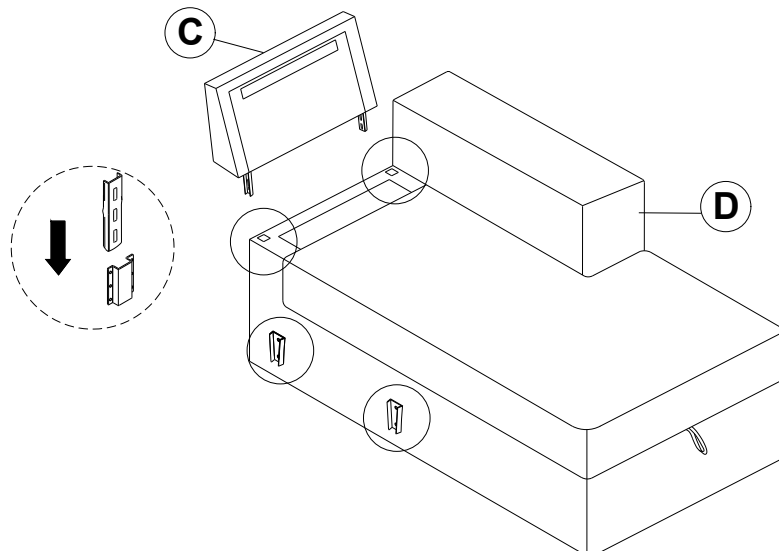

# ITEM: 500359(B1 & B2)

## ASSEMBLY INSTRUCTIONS

### STEP 10

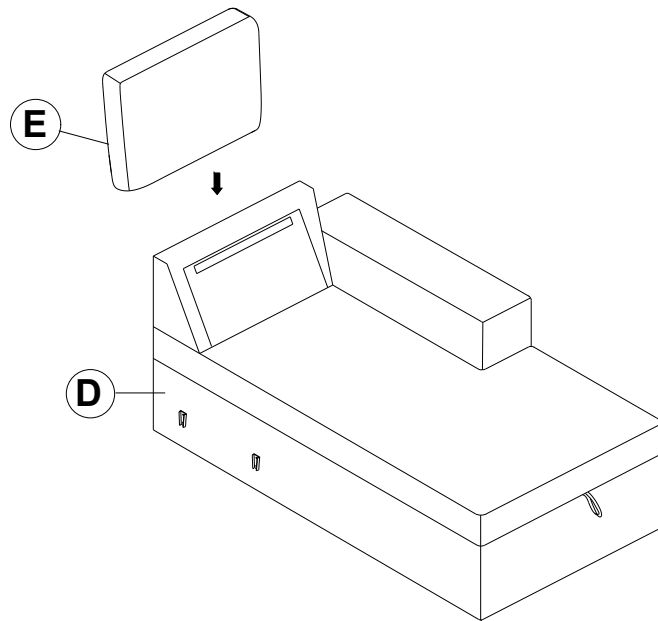

### STEP 11

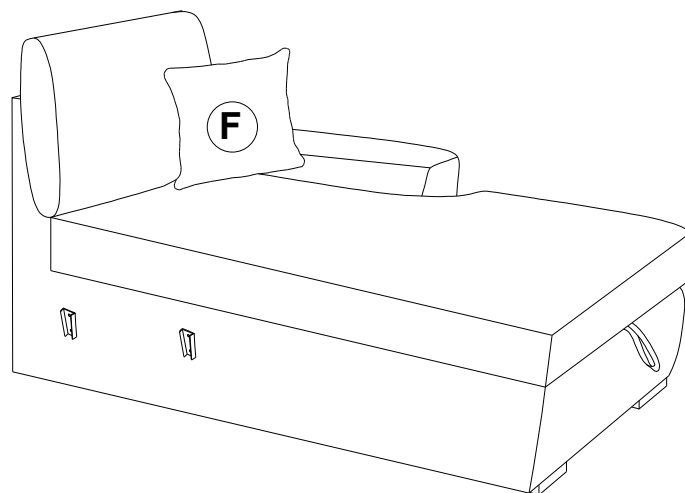

ITEM: **500359(B1 & B2)**  
**ASSEMBLY INSTRUCTIONS**  
**STEP 12**

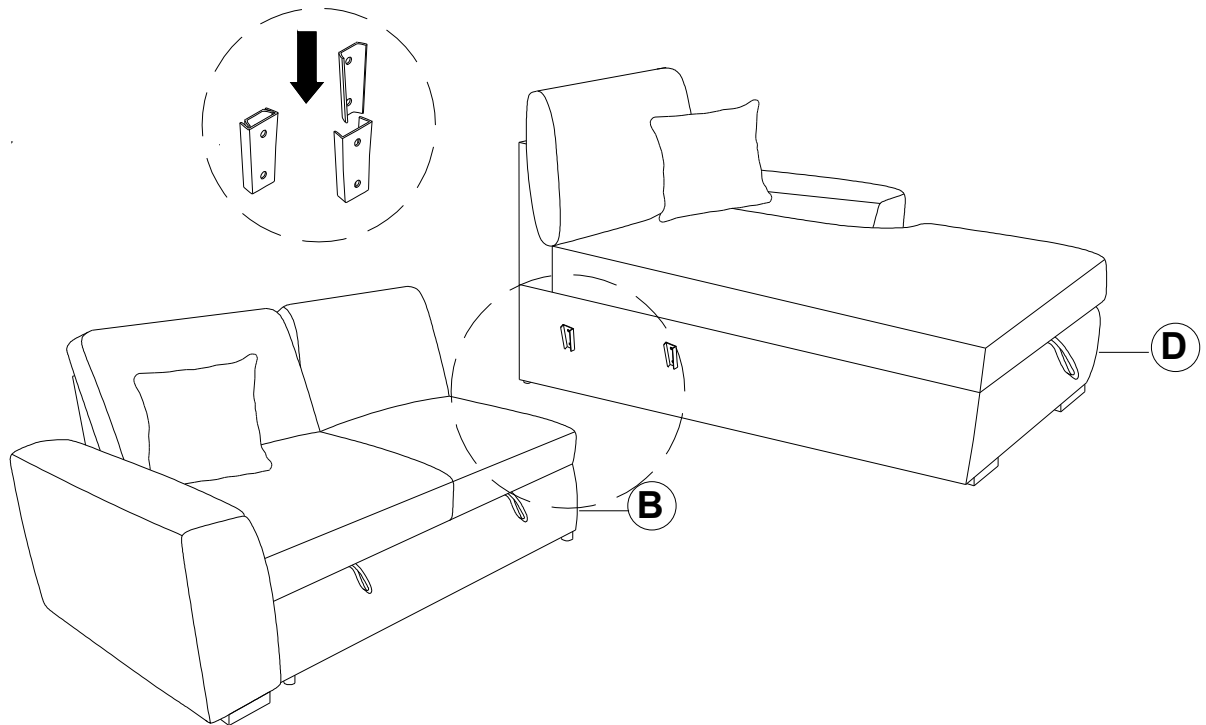

**STEP 13**  
**COMPLETE**

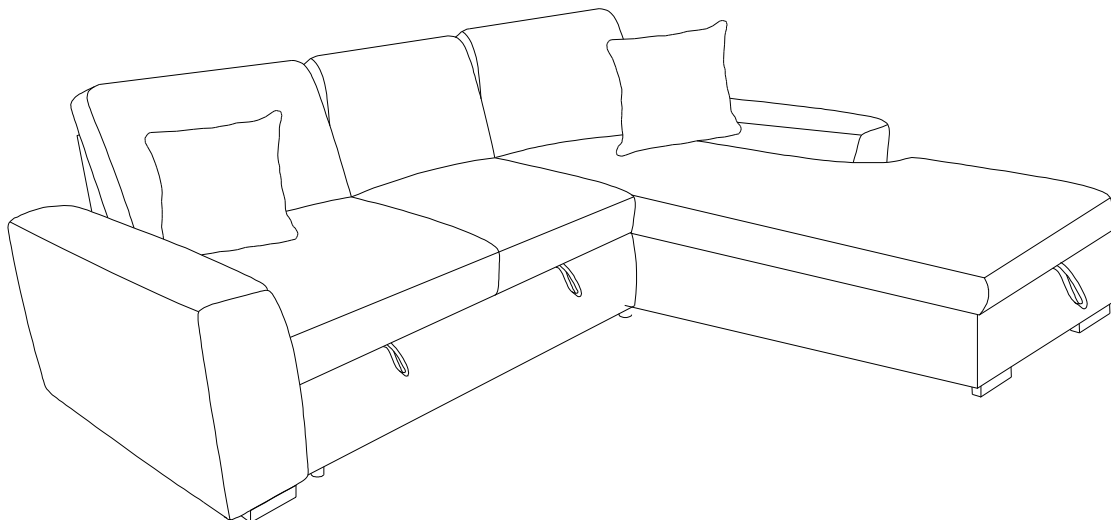

# ITEM: 500359(B1 & B2)

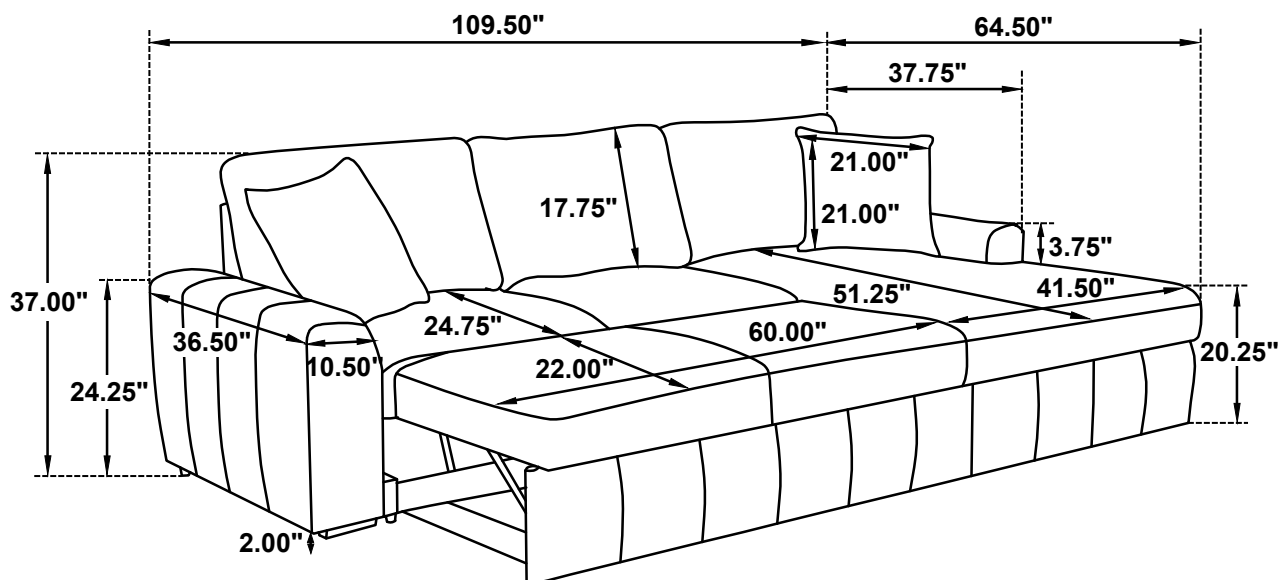

Note: Dimension tolerance  $\pm 5\%$