

ASSEMBLY INSTRUCTIONS
COASTER FINE FURNITURE



Fine Furniture for every stage of life

706437(B1&B2)
End Table

ITEM: 706437(B1&B2)



ASSEMBLY INSTRUCTIONS

ASSEMBLY TIPS:

1. Remove hardware from box and sort by size.
2. Please check to see that all hardware and parts are present prior to start of assembly.
3. Please follow attached instructions in the same sequence as numbered to assure fast & easy assembly.



WARNING!

1. Don't attempt to repair or modify parts that are broken or defective. Please contact the store immediately.
2. This product is for home use only and not intended for commercial establishments.



ASSEMBLY TIME

15 MINUTES

PARTS IDENTIFICATION

B1 (BOX 1)

A TOP

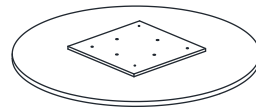

1PC

B MOUNTING PLATE
(PRE-ATTACHED TO TOP)

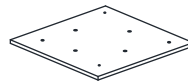

1PC

B2 (BOX 2)

C LEG WITH LABEL "1" (L)



1PC

D LEG WITH LABEL "1" (R)



1PC

E LEG WITH LABEL "2" (L)



1PC

F LEG WITH LABEL "2" (R)



1PC

HARDWARE IDENTIFICATION

Z-B1 (BOX 1) - HARDWARE PACK IS LOCATED IN 706437 (B1)

1 ALLEN WRENCH
(M4 X 60MM - BLK)



1PC

2 BOLT
(M6 X 25MM - RBW)



4PCS

3 LOCK WASHER
(M6 X 13MM - RBW)



4PCS

4 FLAT WASHER
(M6 X 13MM - RBW)



4PCS

5 WOOD DOWEL
(M8 X 30MM)

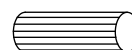

14PCS

6 LEVELER
(M6 X 23MM)



6PCS

ITEM: 706437(B1&B2)



ASSEMBLY INSTRUCTIONS

STEP 1

Attention! Please remove part B and all hardware from TOP (A), using ALLEN WRENCH (1) and keep for STEP 8 and STEP 9.

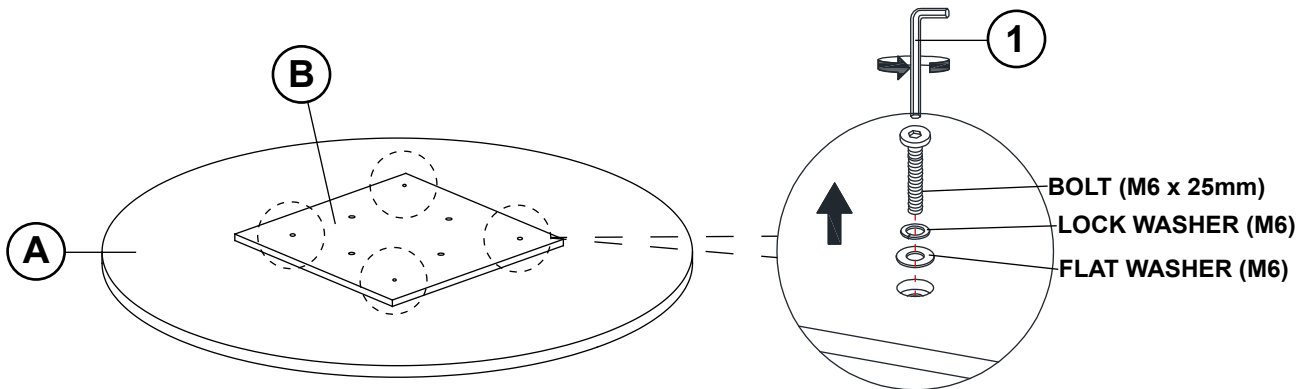

STEP 2

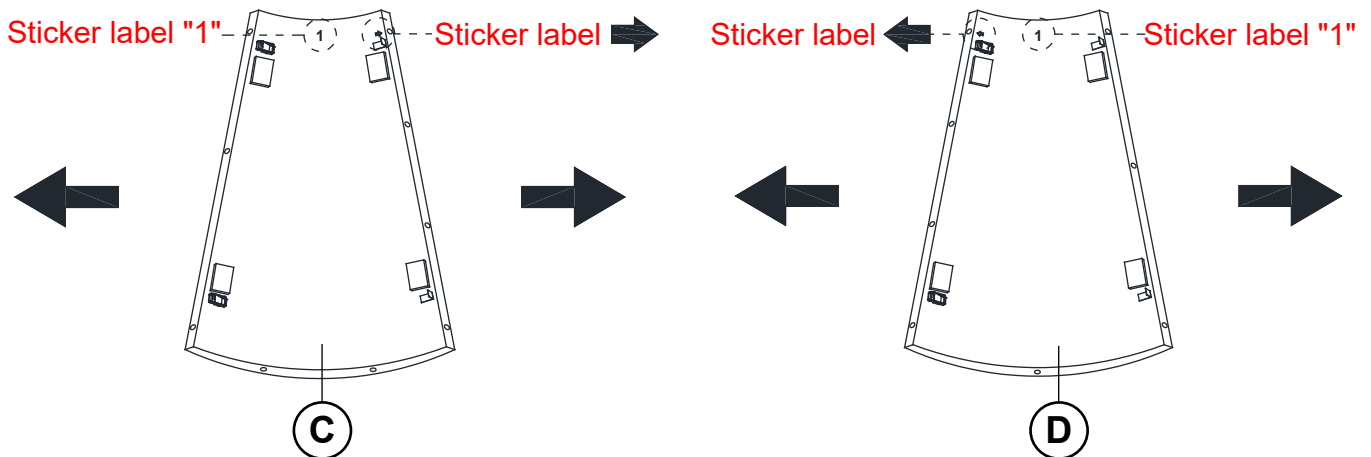

STEP 3

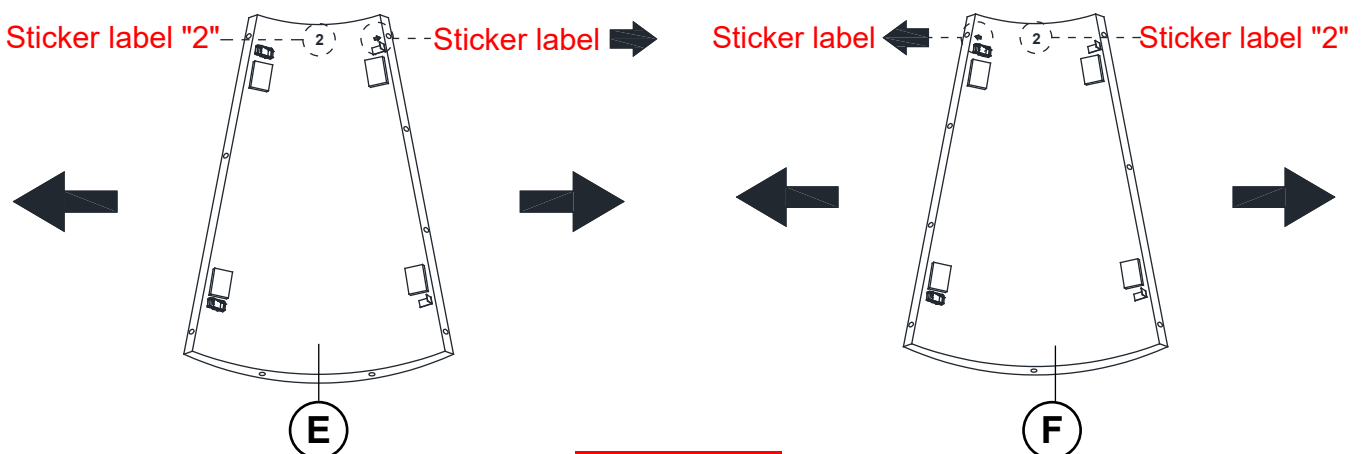

ITEM: 706437(B1&B2)

ASSEMBLY INSTRUCTIONS



STEP 4

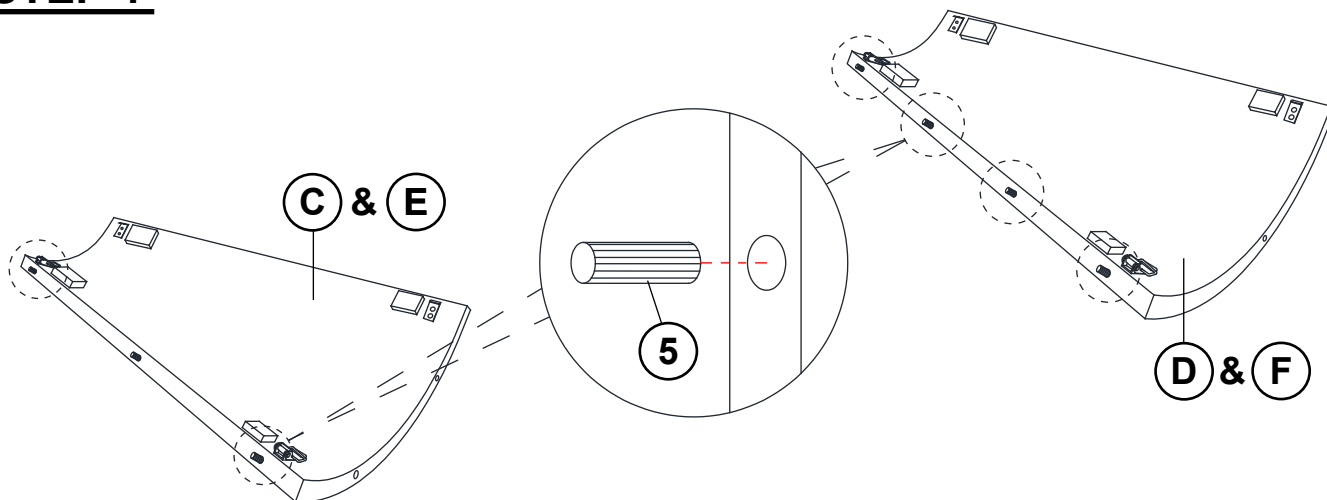

STEP 5

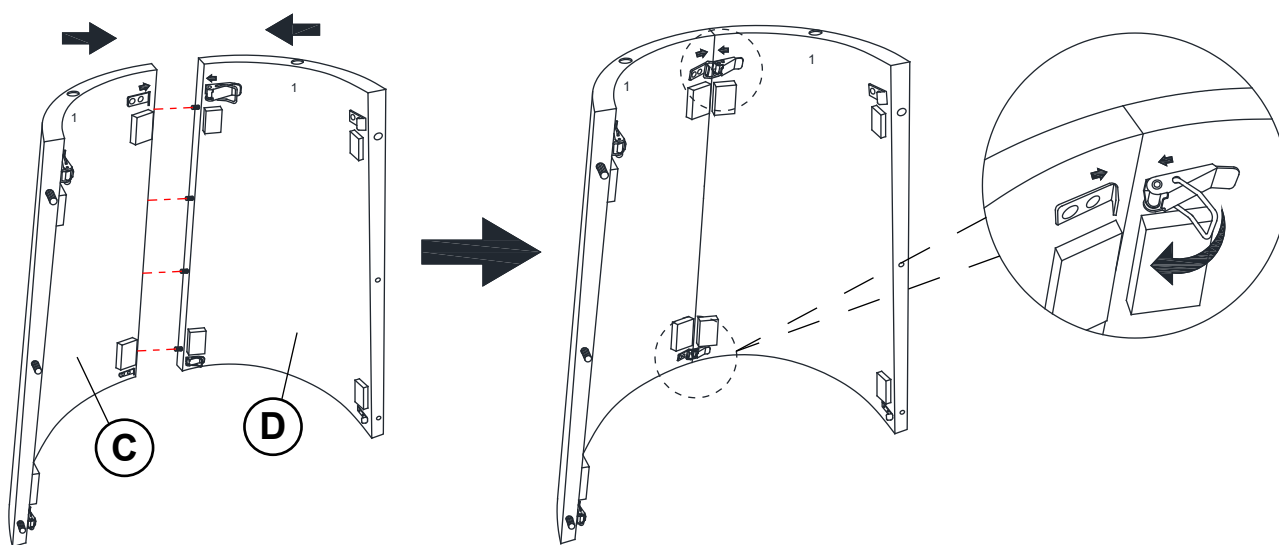

STEP 6

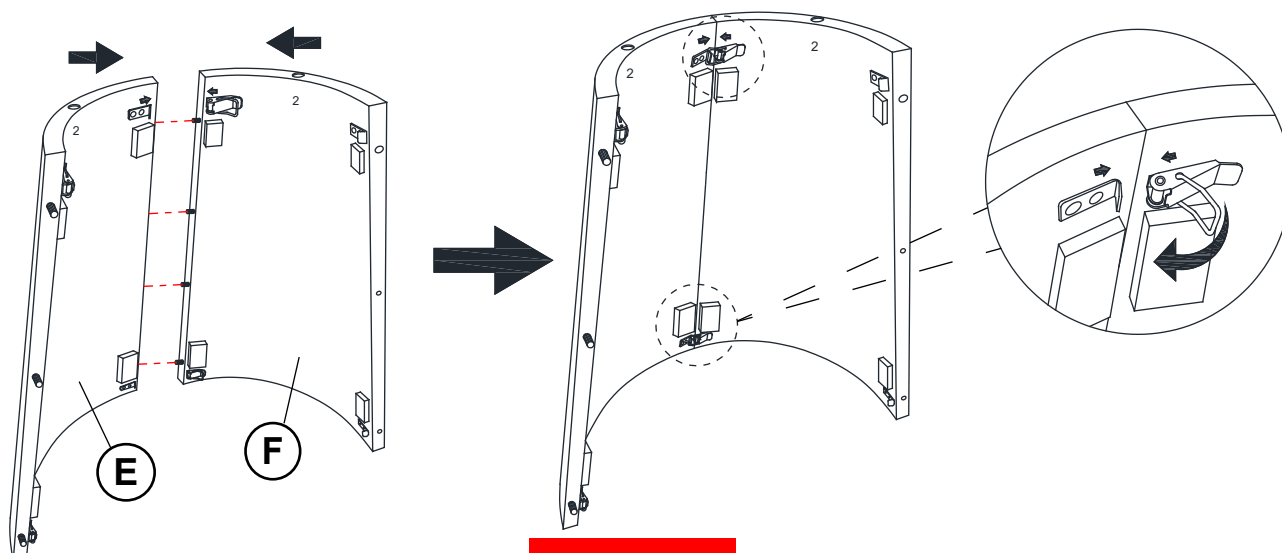

ITEM: 706437(B1&B2)

ASSEMBLY INSTRUCTIONS



STEP 7

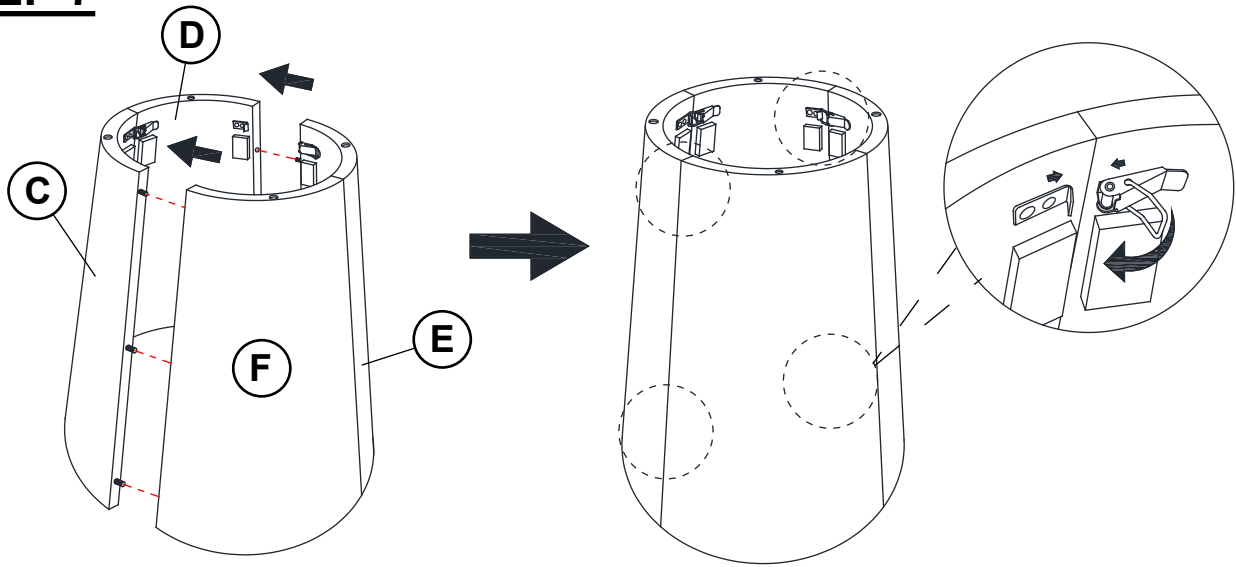

STEP 8

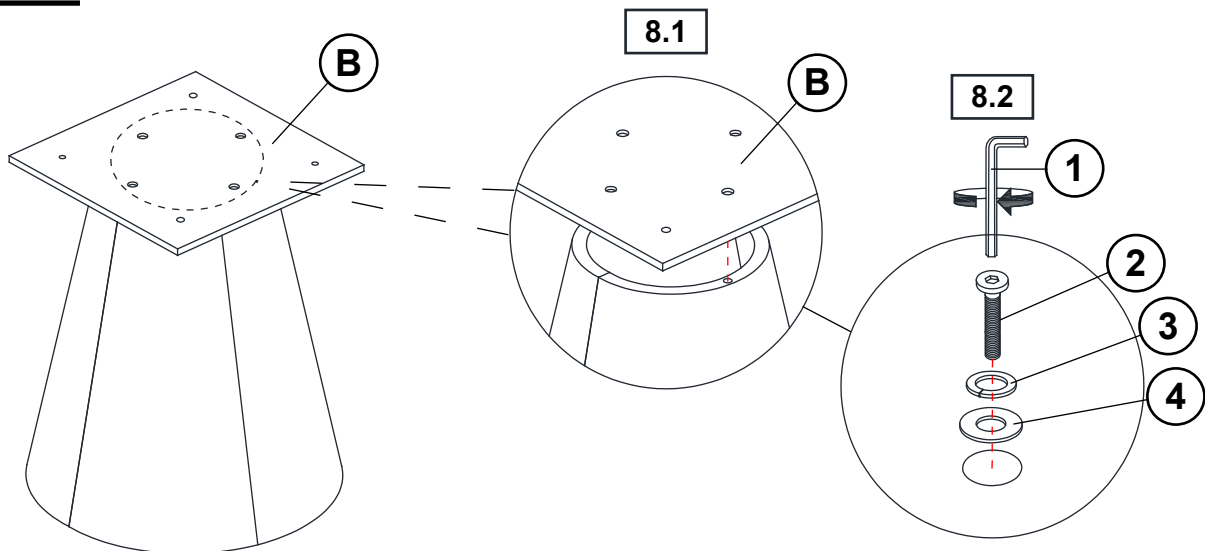

STEP 9

Attention! Use hardware from STEP 1 for this STEP.

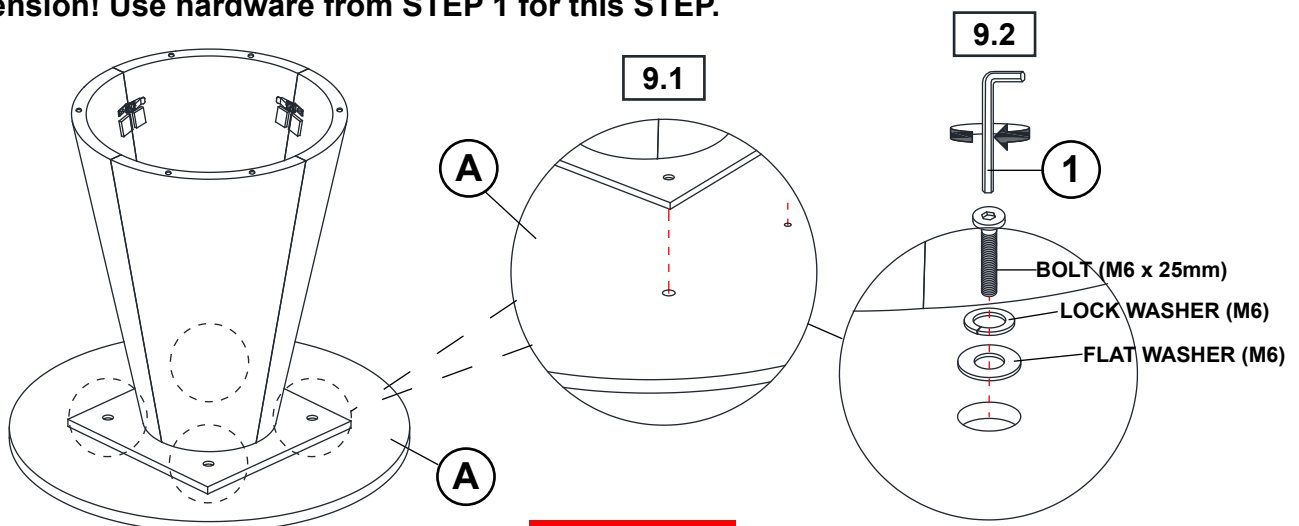

*BOTTOM VIEW

ITEM: **706437(B1&B2)**

ASSEMBLY INSTRUCTIONS

STEP 10

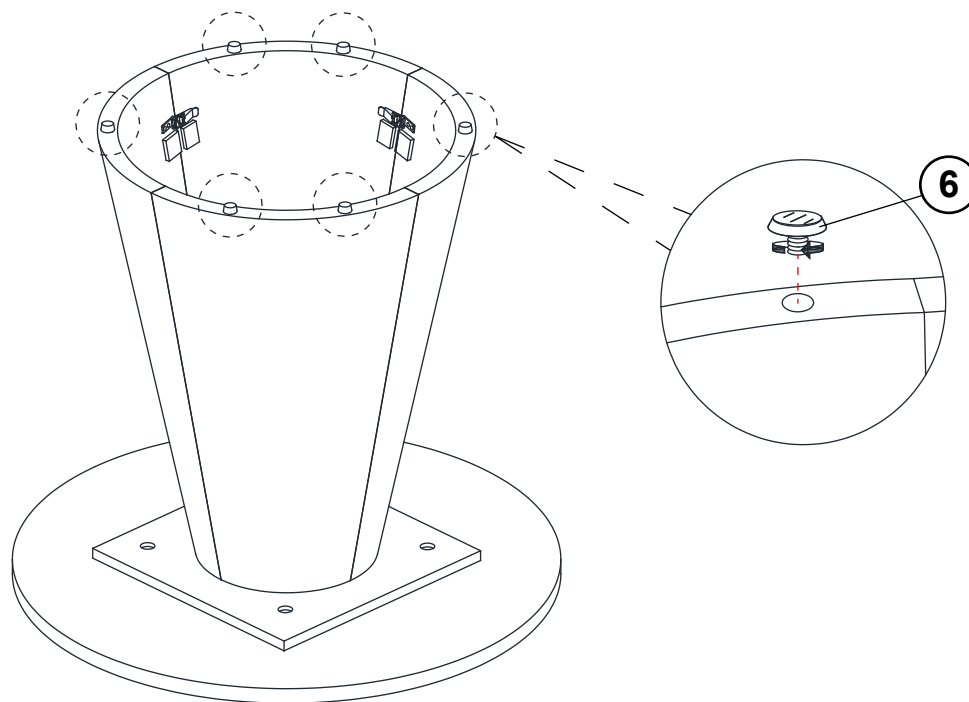

STEP 11

COMPLETE

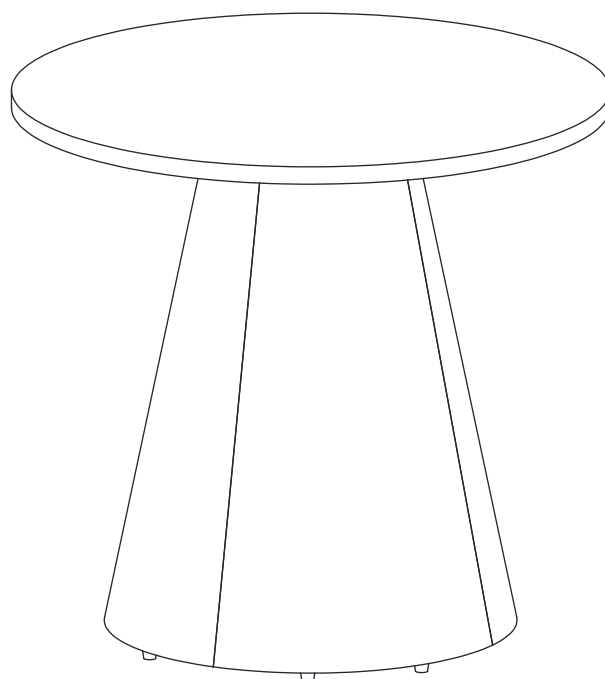

ITEM: 706437(B1&B2)

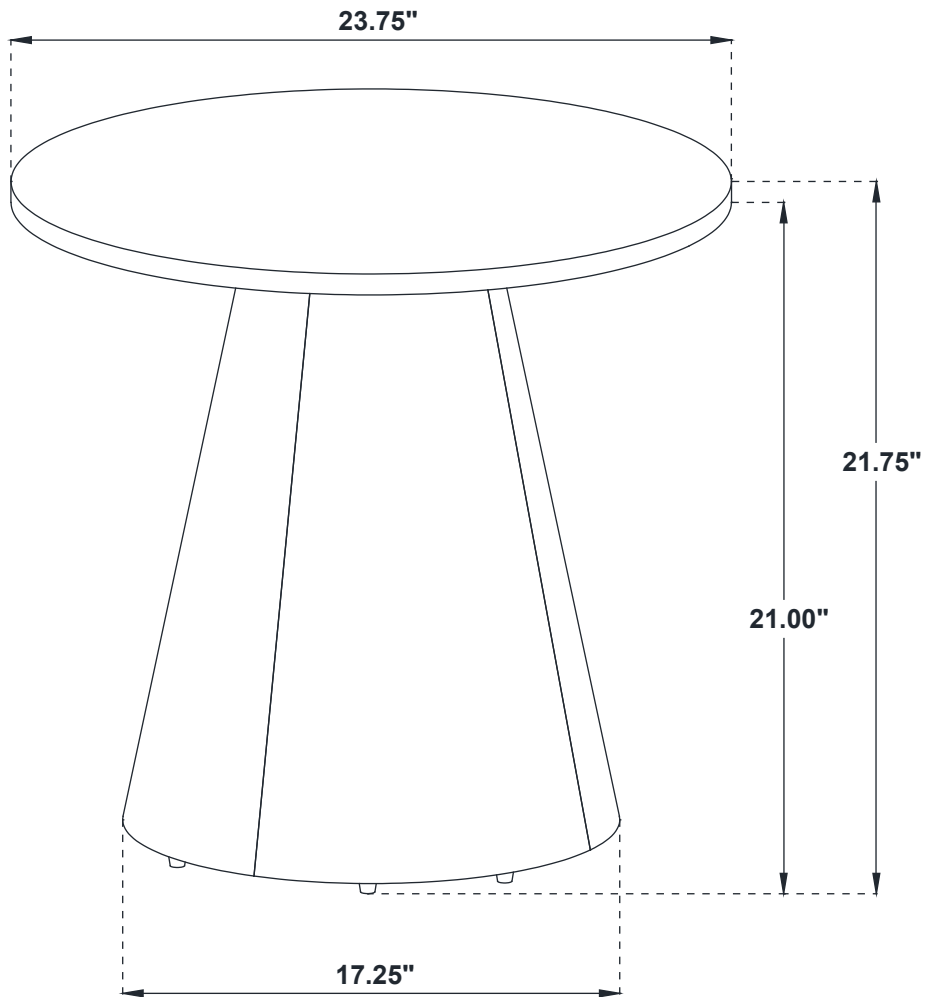

Note: Dimension tolerance $\pm 5\%$

ASSEMBLY INSTRUCTIONS
COASTER FINE FURNITURE



Fine Furniture for every stage of life

706438(B1&B2)
Coffee Table

ITEM: 706438(B1&B2)

ASSEMBLY INSTRUCTIONS



ASSEMBLY TIPS:

1. Remove hardware from box and sort by size.
2. Please check to see that all hardware and parts are present prior to start of assembly.
3. Please follow attached instructions in the same sequence as numbered to assure fast & easy assembly.



WARNING!

1. Don't attempt to repair or modify parts that are broken or defective. Please contact the store immediately.
2. This product is for home use only and not intended for commercial establishments.



ASSEMBLY TIME

15 MINUTES

PARTS IDENTIFICATION

B1 (BOX 1)

A TOP

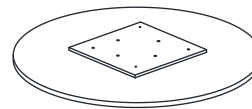

1PC

B MOUNTING PLATE
(PRE-ATTACHED TO TOP)

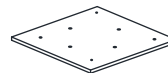

1PC

B2 (BOX 2)

C LEG WITH LABEL "1" (L)



1PC

D LEG WITH LABEL "1" (R)



1PC

E LEG WITH LABEL "2" (L)



1PC

F LEG WITH LABEL "2" (R)



1PC

HARDWARE IDENTIFICATION

Z-B1 (BOX 1) - HARDWARE PACK IS LOCATED IN 706438 (B1)

1 ALLEN WRENCH
(M4 X 60MM - BLK)



1PC

2 BOLT
(M6 X 25MM - RBW)



4PCS

3 LOCK WASHER
(M6 X 13MM - RBW)



4PCS

4 FLAT WASHER
(M6 X 13MM - RBW)



4PCS

5 WOOD DOWEL
(M8 X 30MM)

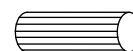

14PCS

6 LEVELER
(M6 X 23MM)



6PCS

ITEM: 706438(B1&B2)



ASSEMBLY INSTRUCTIONS

STEP 1

Attention! Please remove part B and all hardware from TOP (A), using ALLEN WRENCH (1) and keep for STEP 8 and STEP 9.

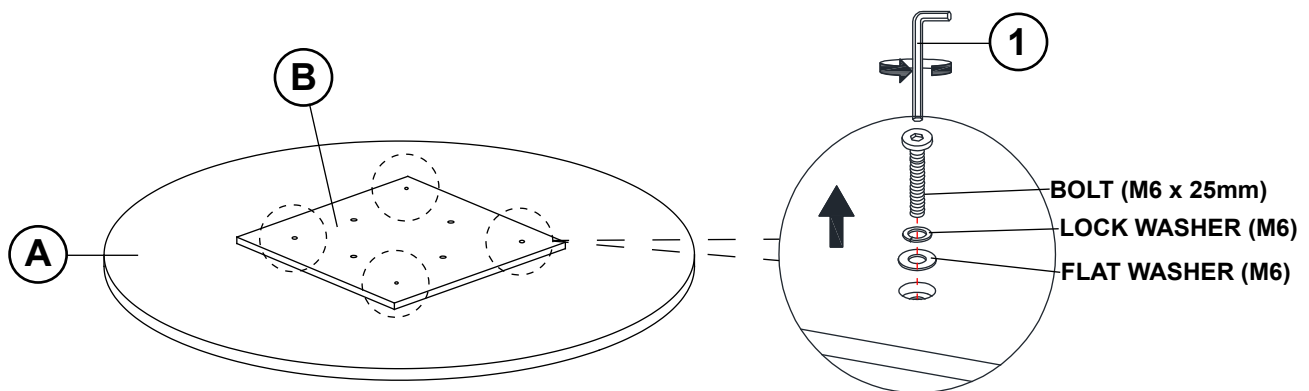

STEP 2

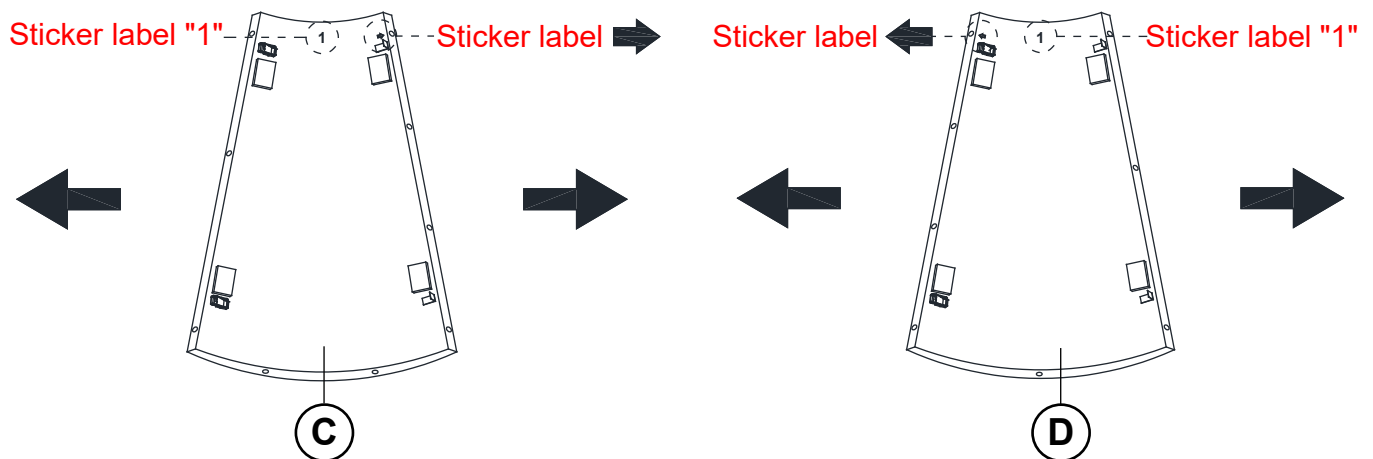

STEP 3

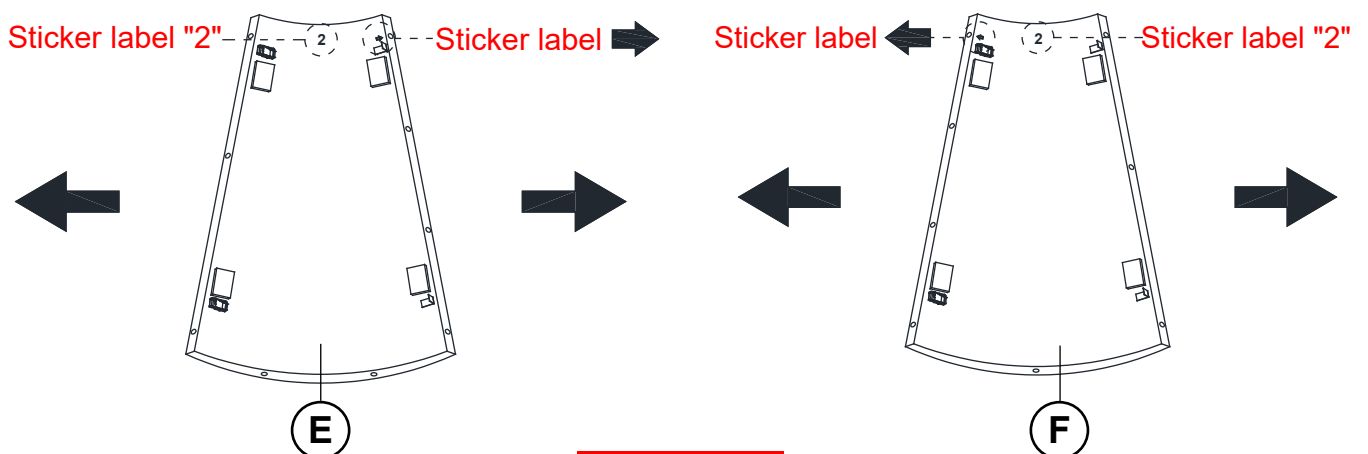

ITEM: 706438(B1&B2)

ASSEMBLY INSTRUCTIONS

STEP 4

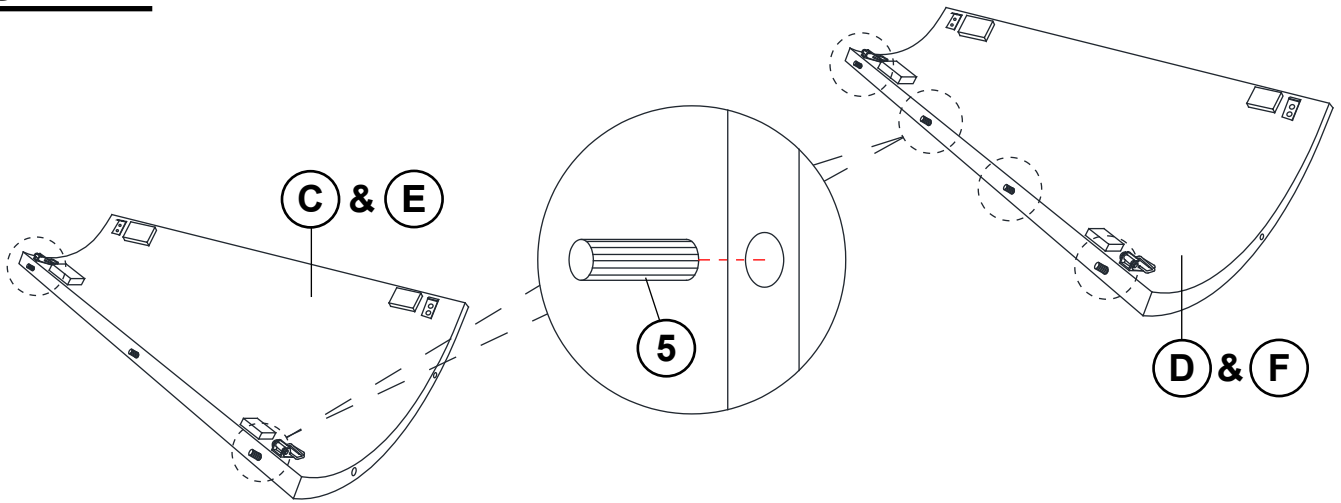

STEP 5

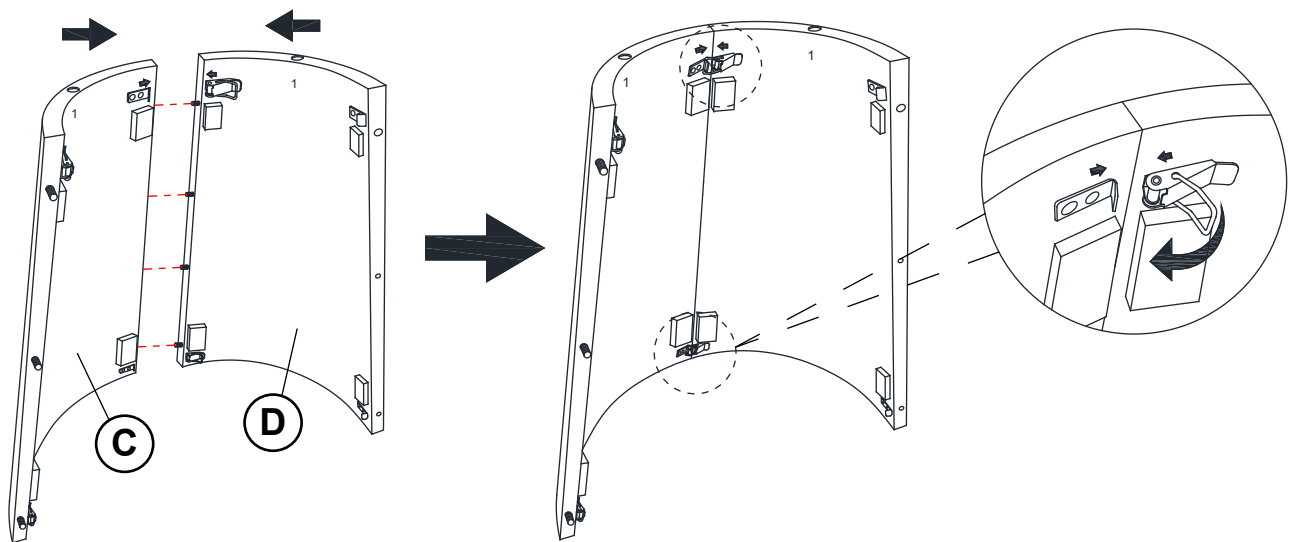

STEP 6

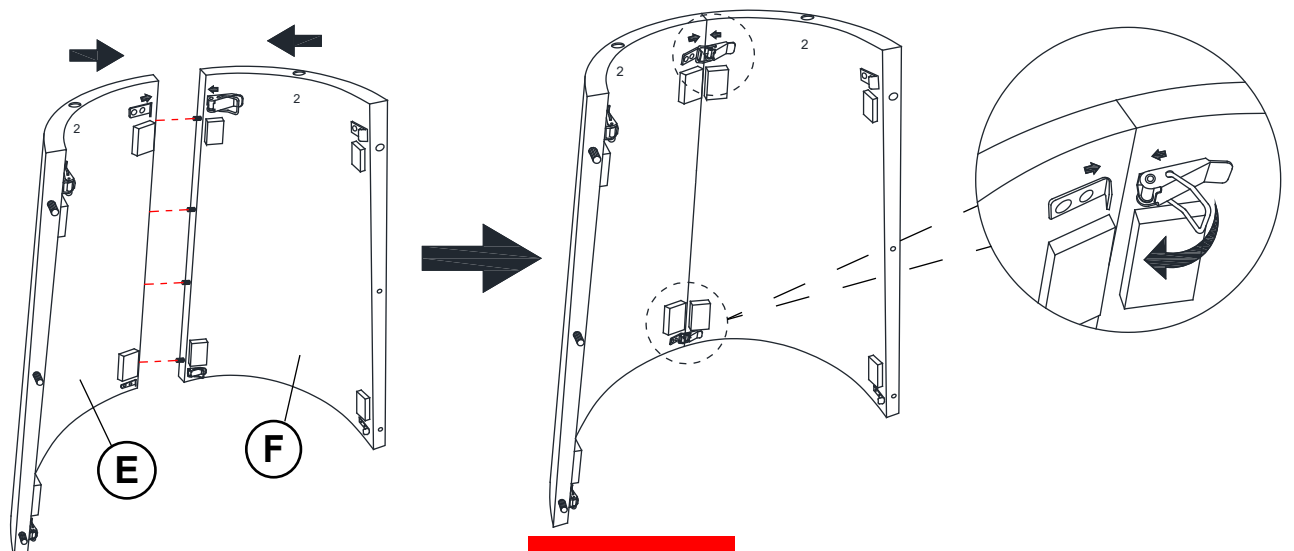

ITEM: 706438(B1&B2)

ASSEMBLY INSTRUCTIONS



STEP 7

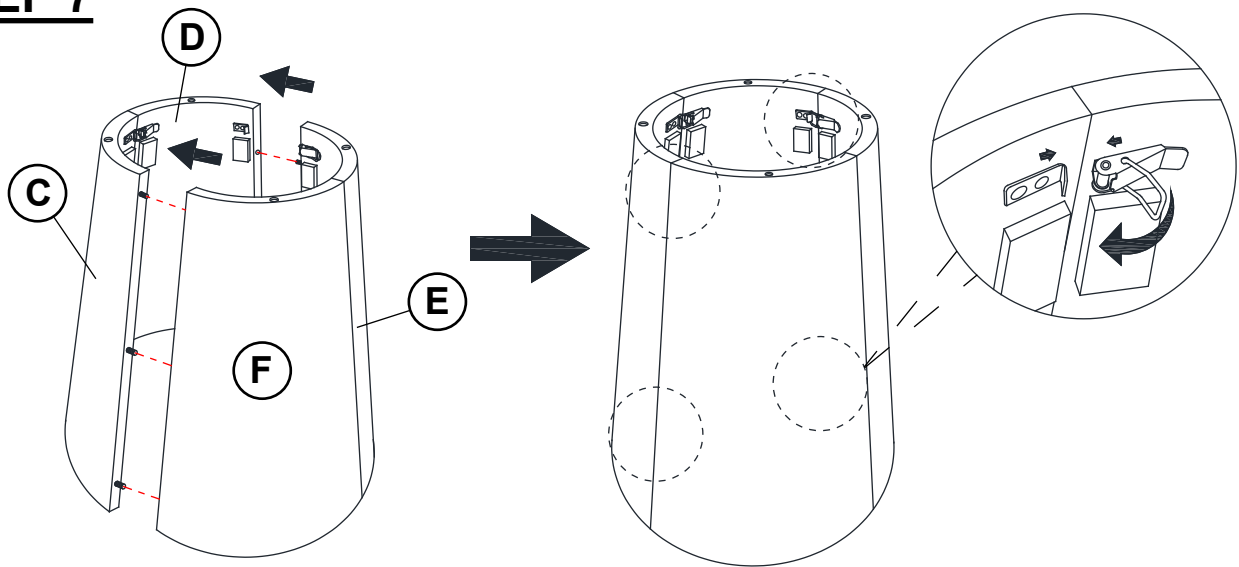

STEP 8

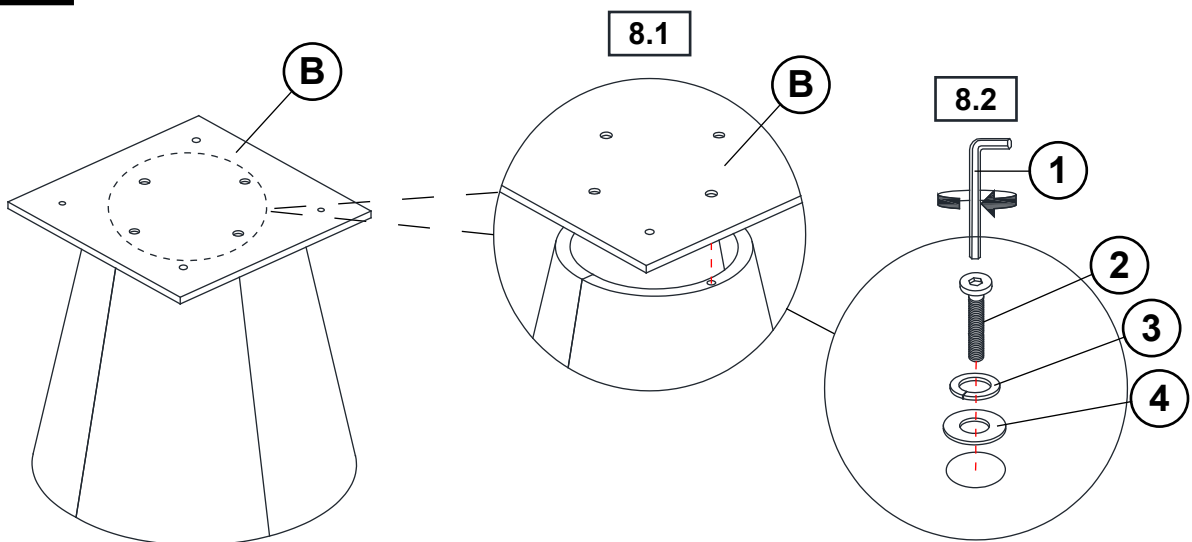

STEP 9

Attention! Use hardware from STEP 1 for this STEP.

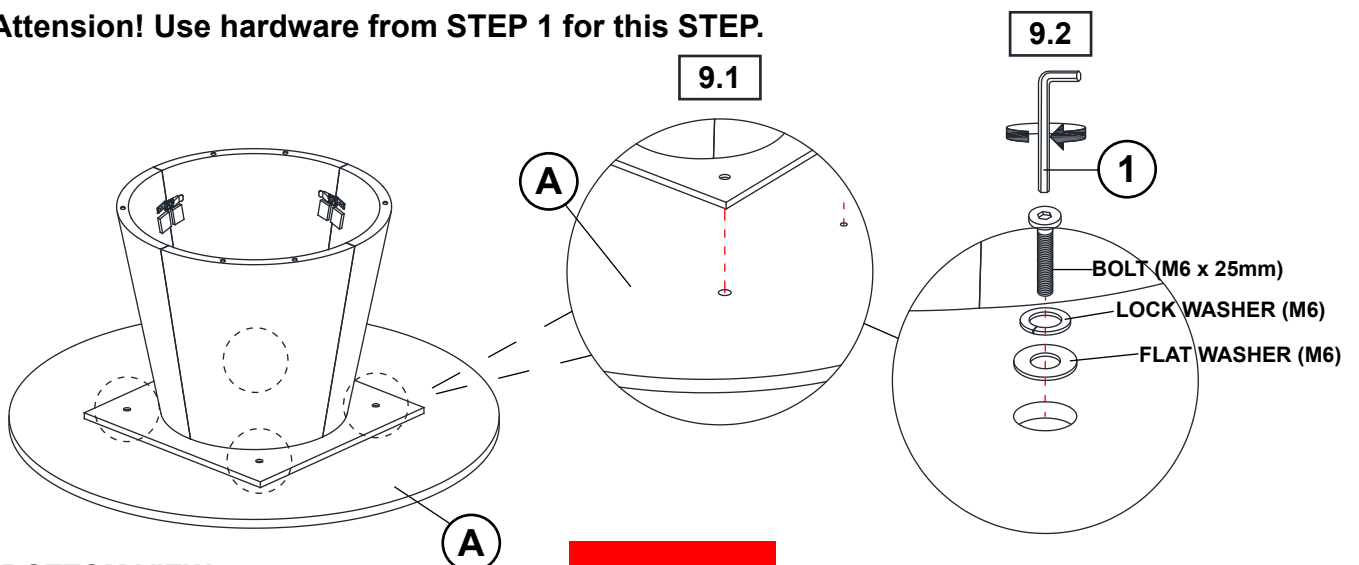

*BOTTOM VIEW

ITEM: **706438(B1&B2)**

ASSEMBLY INSTRUCTIONS

STEP 10

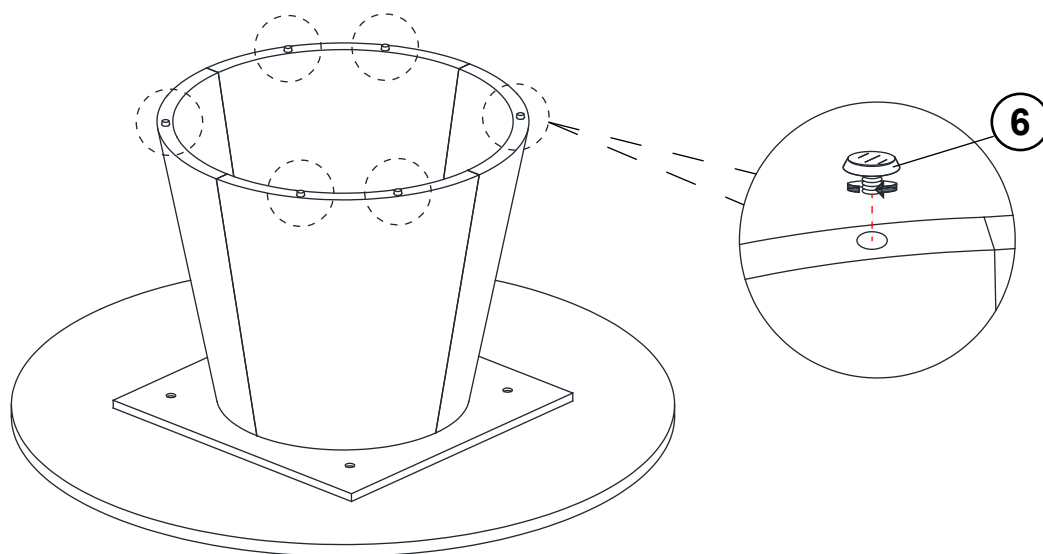

STEP 11

COMPLETE

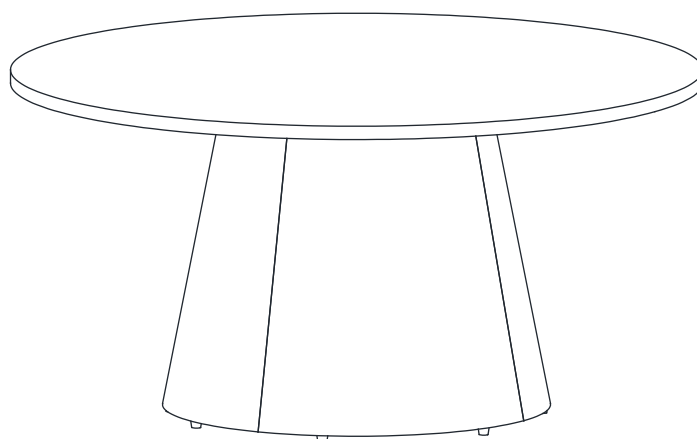

ITEM: **706438(B1&B2)**

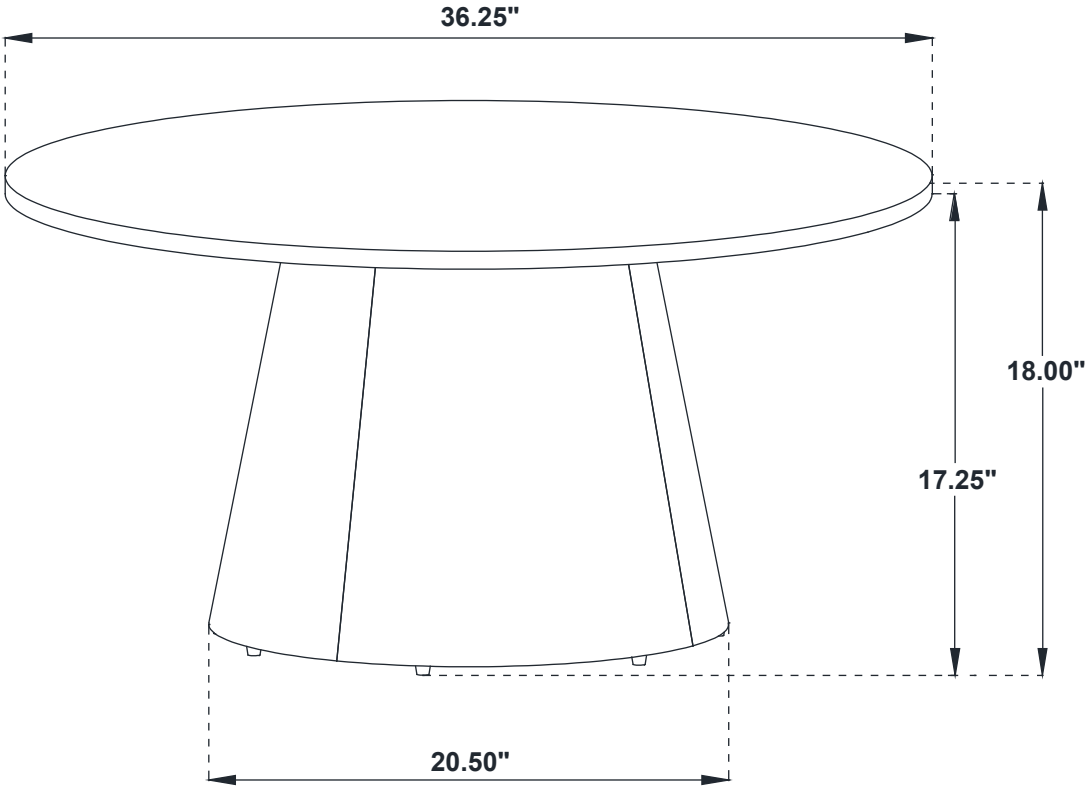

Note: Dimension tolerance $\pm 5\%$