

ASSEMBLY INSTRUCTIONS
COASTER FINE FURNITURE



Fine Furniture for every stage of life

722727
End Table

ITEM: **722727**

ASSEMBLY INSTRUCTIONS



ASSEMBLY TIPS:

1. Remove hardware from box and sort by size.
2. Please check to see that all hardware and parts are present prior to start of assembly.
3. Please follow attached instructions in the same sequence as numbered to assure fast & easy assembly.



WARNING!

1. Don't attempt to repair or modify parts that are broken or defective. Please contact the store immediately.
2. This product is for home use only and not intended for commercial establishments.



ASSEMBLY TIME

15 MINUTES

PARTS IDENTIFICATION

A	TOP		1PC
B	LEG		4PCS
C	SHELF		1PC

HARDWARE IDENTIFICATION

1	BOLT (1/4" x 50mm - BLK)		12PCS
2	LOCK WASHER (1/4" x 14mm - BLK)		12PCS
3	FLAT WASHER (1/4" x 19mm - BLK)		12PCS
4	ALLEN WRENCH (4mm x 110mm - BLK)		1PC

ITEM: **722727**
ASSEMBLY INSTRUCTIONS

STEP 1

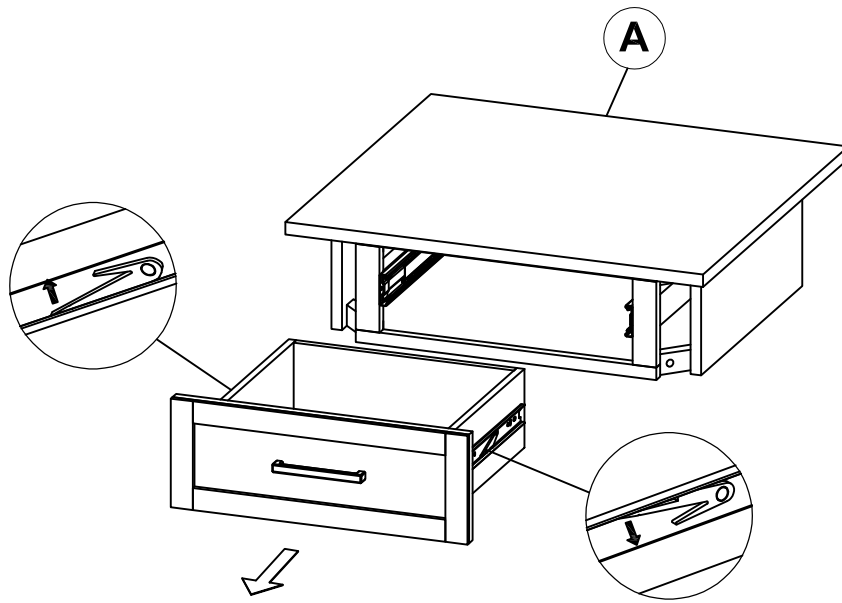

STEP 2

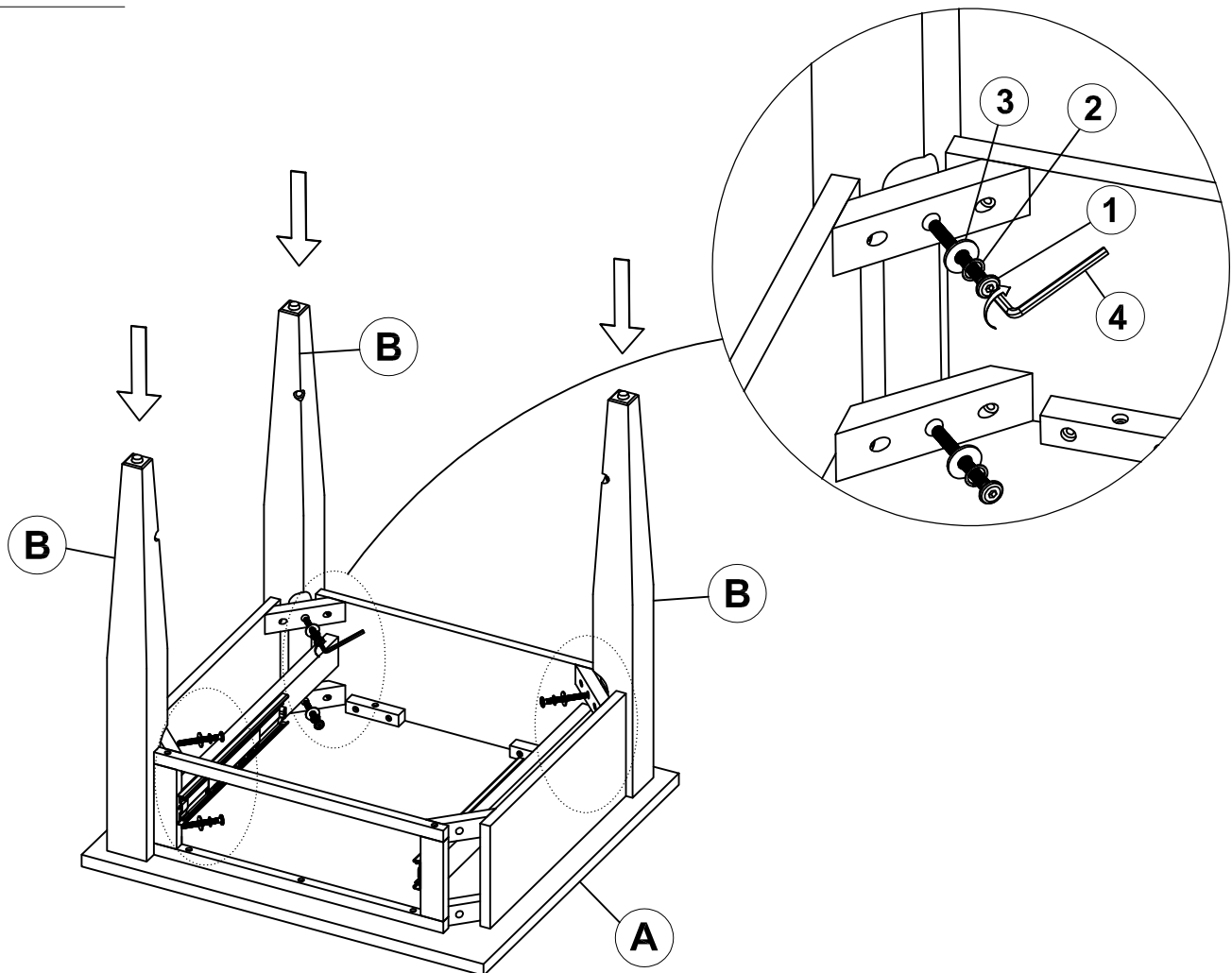

ITEM: **722727**
ASSEMBLY INSTRUCTIONS

STEP 3

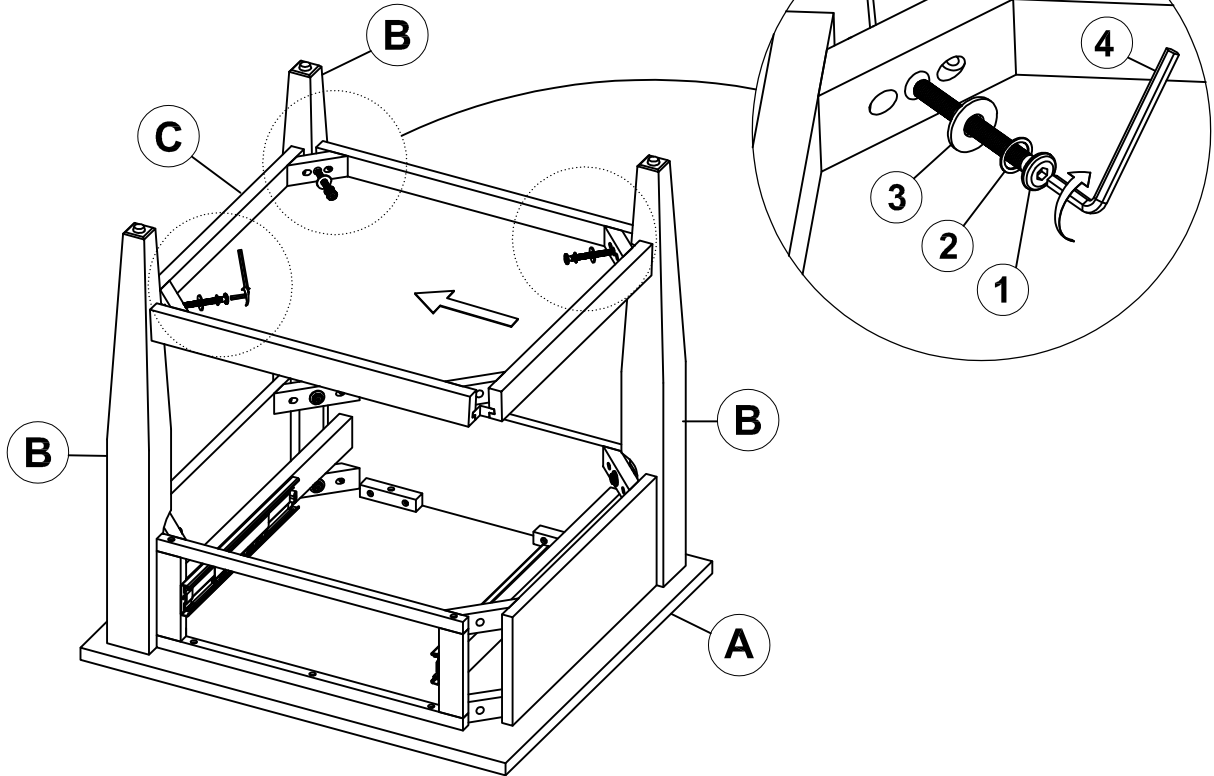

STEP 4

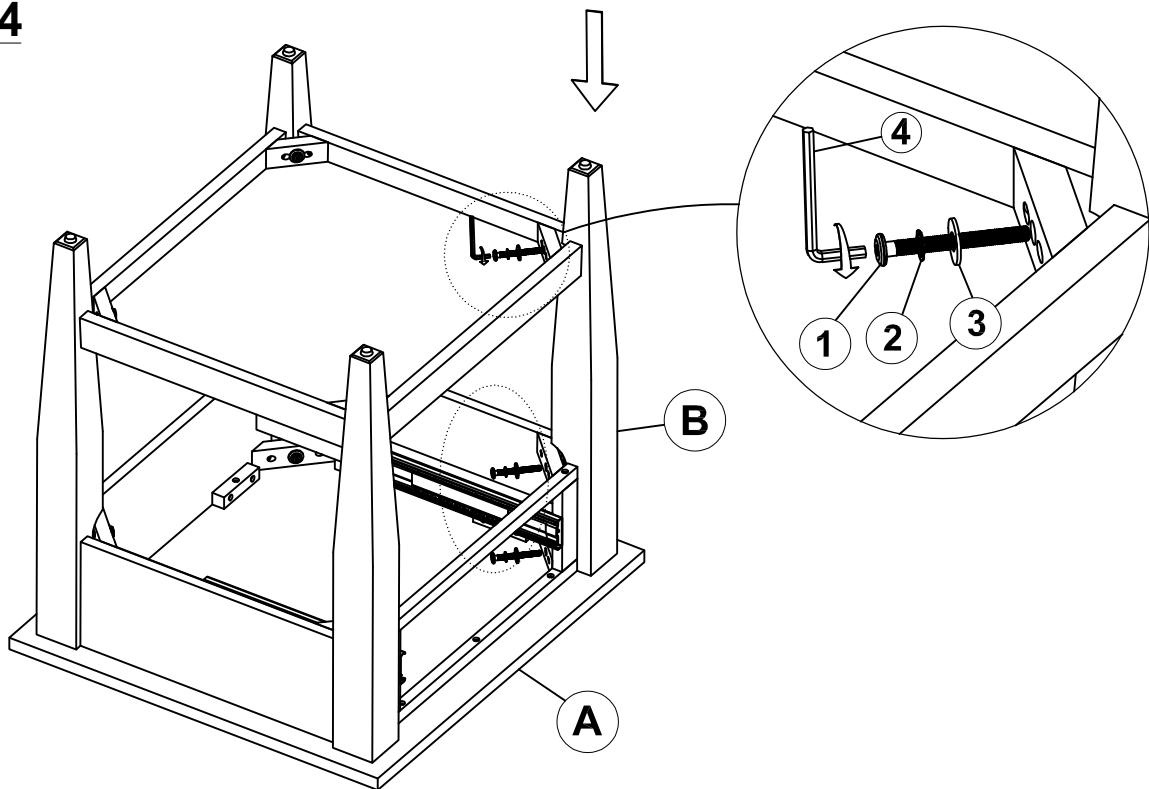

ITEM: **722727**

ASSEMBLY INSTRUCTIONS

STEP 5

COMPLETE

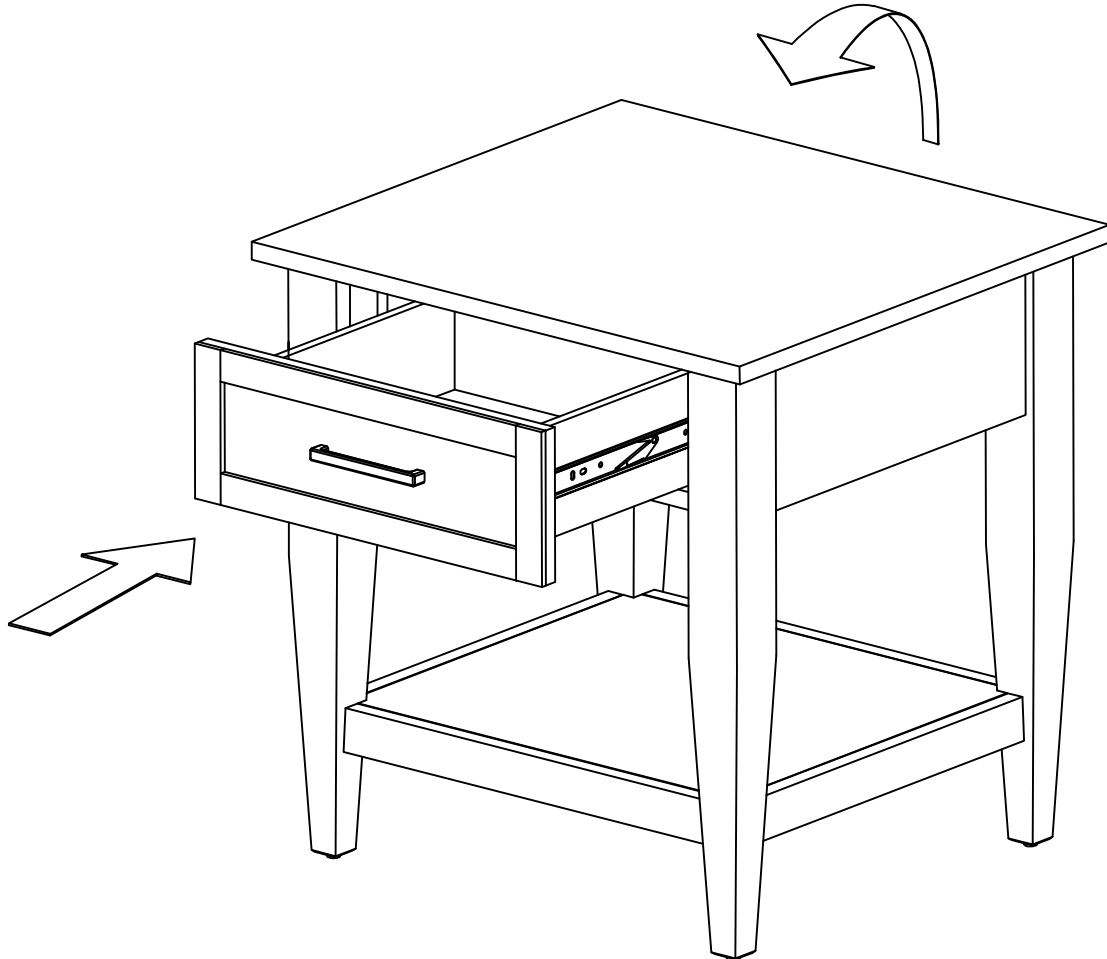

ITEM: 722727



Inner Size of Drawer: 12.75"W x 11.75"D x 4.00"H x 0.50"T

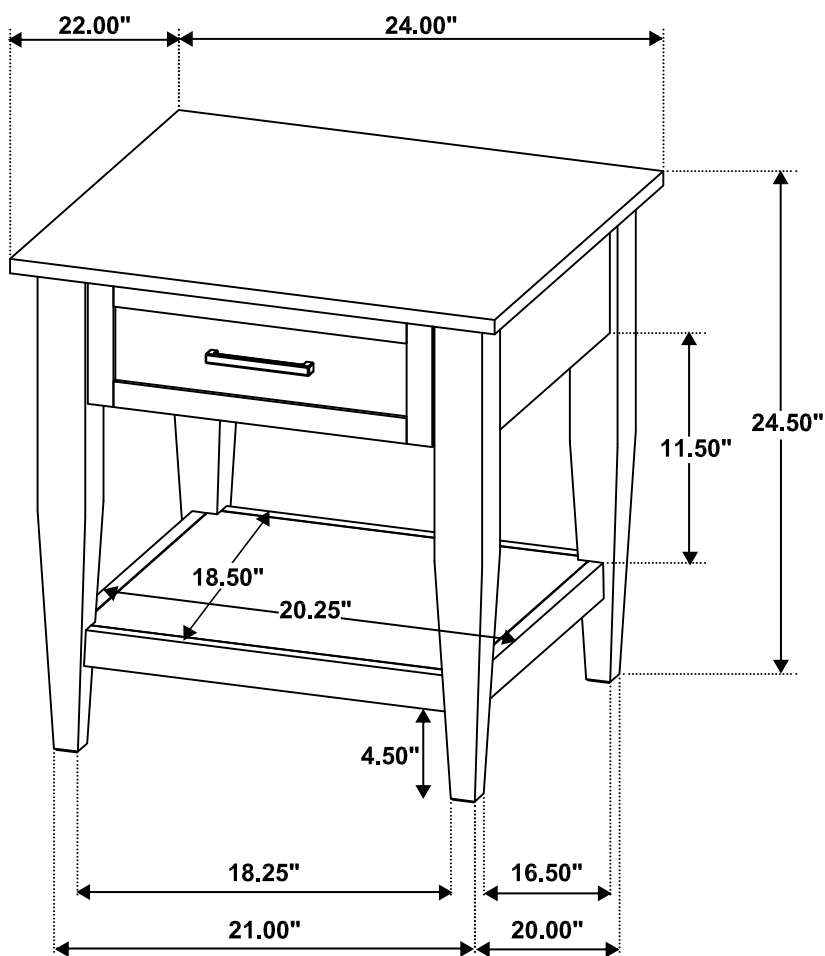

Note: Dimension tolerance $\pm 5\%$

ASSEMBLY INSTRUCTIONS
COASTER FINE FURNITURE



Fine Furniture for every stage of life

722728
Lift Top Coffee Table

ITEM: 722728



ASSEMBLY INSTRUCTIONS

ASSEMBLY TIPS:

1. Remove hardware from box and sort by size.
2. Please check to see that all hardware and parts are present prior to start of assembly.
3. Please follow attached instructions in the same sequence as numbered to assure fast & easy assembly.



WARNING!



1. Don't attempt to repair or modify parts that are broken or defective. Please contact the store immediately.
2. This product is for home use only and not intended for commercial establishments.





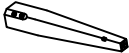

ASSEMBLY TIME

15 MINUTES

PARTS IDENTIFICATION

A	TOP		1PC
B	LEG		4PCS
C	SHELF		1PC

HARDWARE IDENTIFICATION

1	BOLT (1/4" x 50mm - BLK)		12PCS
2	LOCK WASHER (1/4" x 14mm - BLK)		12PCS
3	FLAT WASHER (1/4" x 19mm - BLK)		12PCS
4	ALLEN WRENCH (4mm x 64mm - BLK)		1PC

NOTE:

Phillips head screw driver is required in the assembly process; however, manufacturer does not provide this item.

ITEM: **722728**
ASSEMBLY INSTRUCTIONS



STEP 1

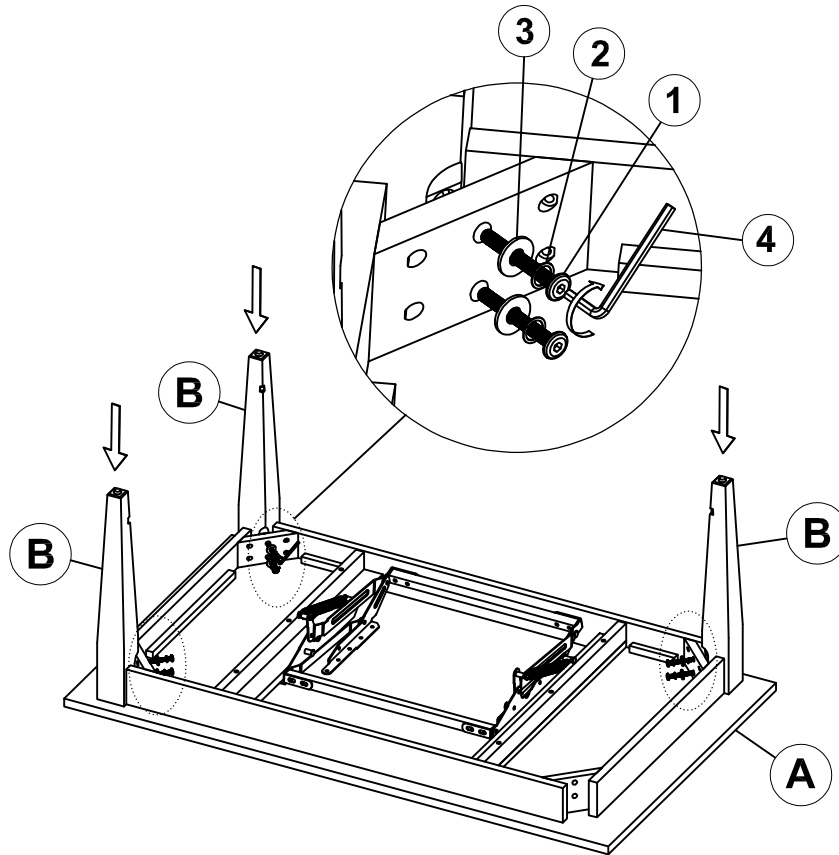

STEP 2

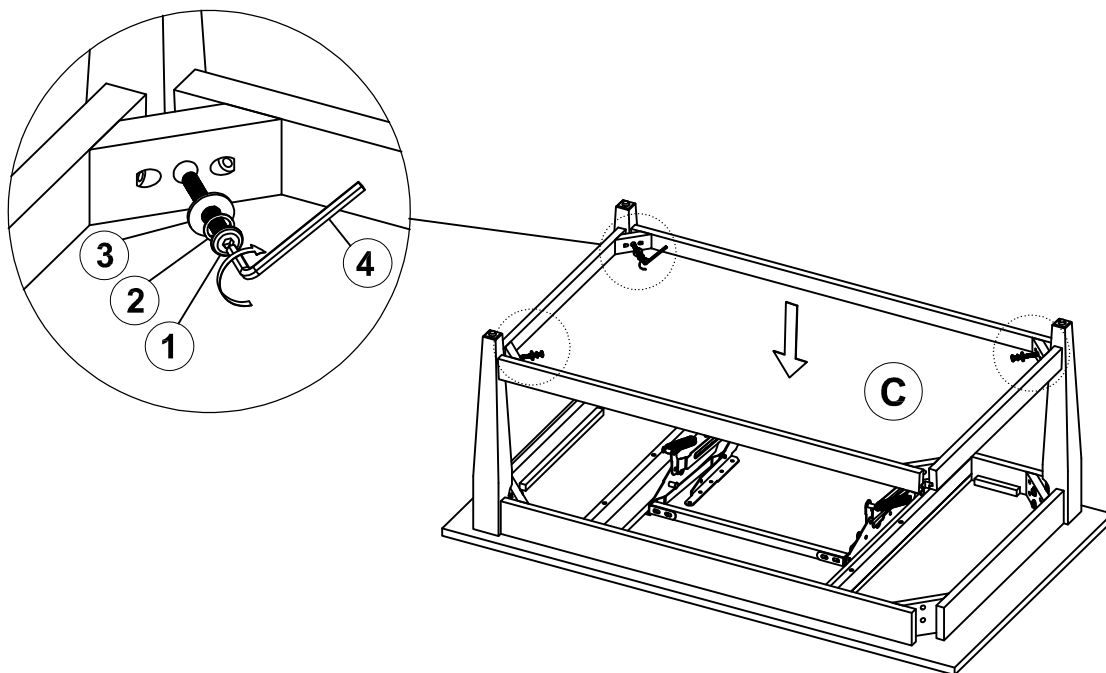

ITEM: **722728**
ASSEMBLY INSTRUCTIONS



STEP 3

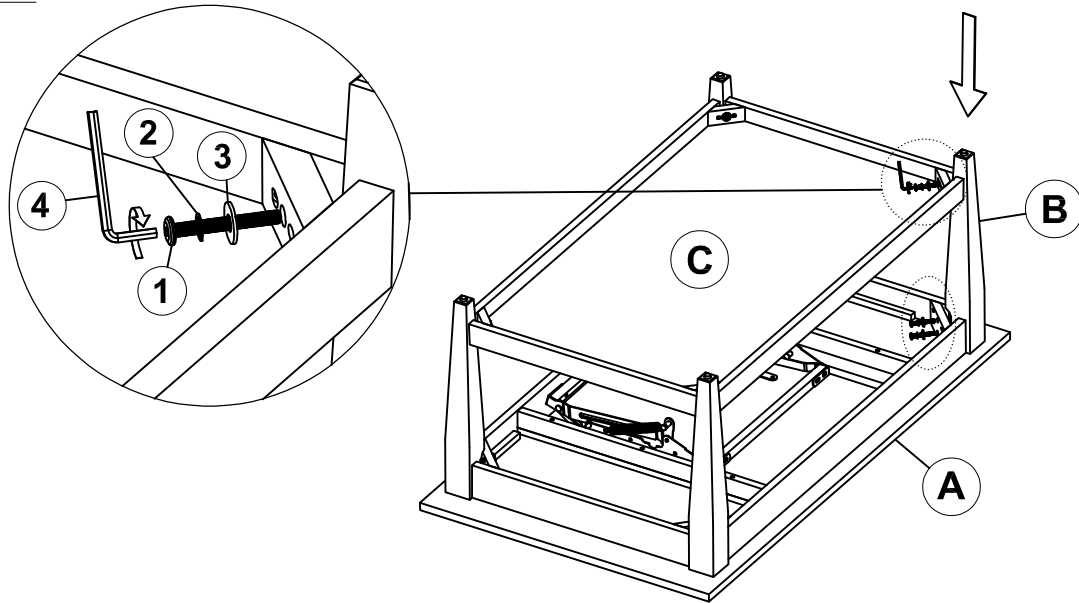

STEP 4

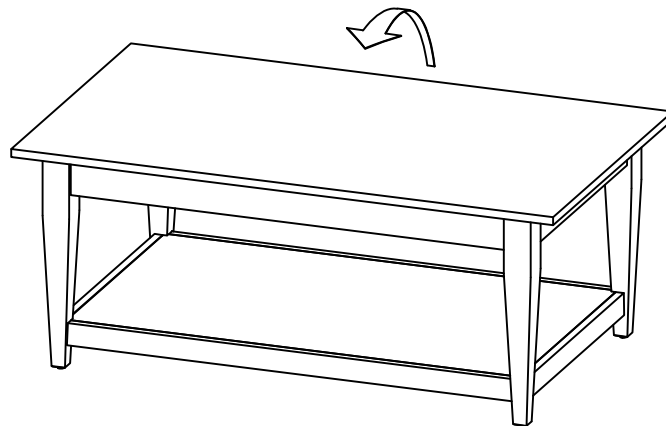

STEP 5
COMPLETE

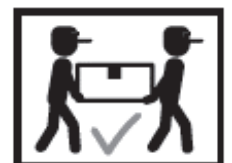
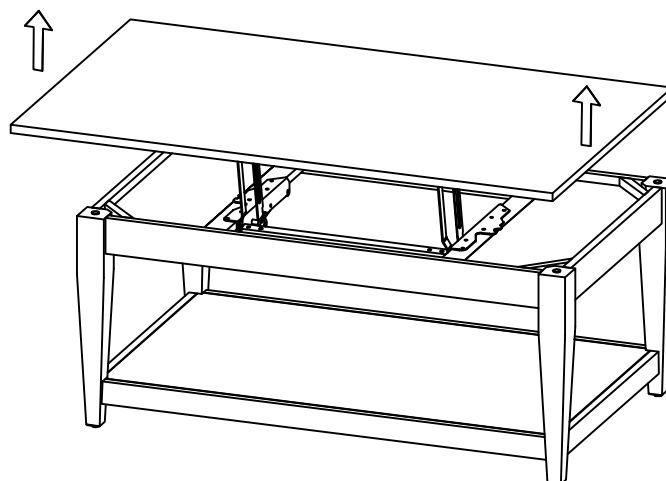

ITEM: 722728

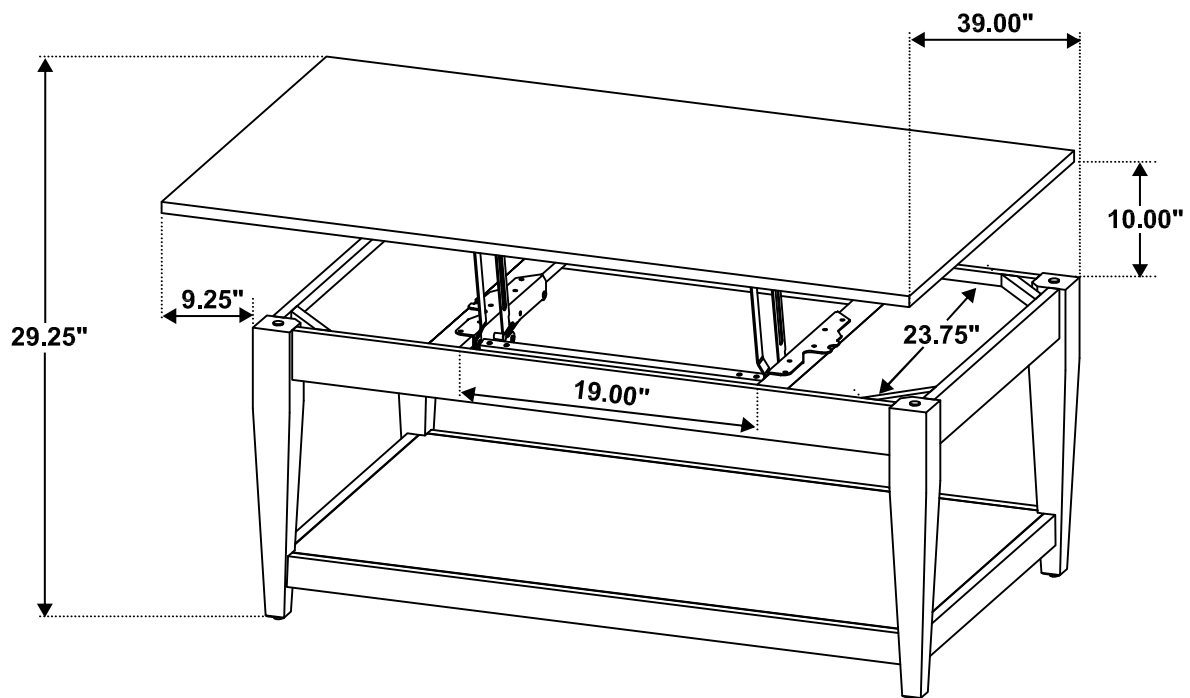
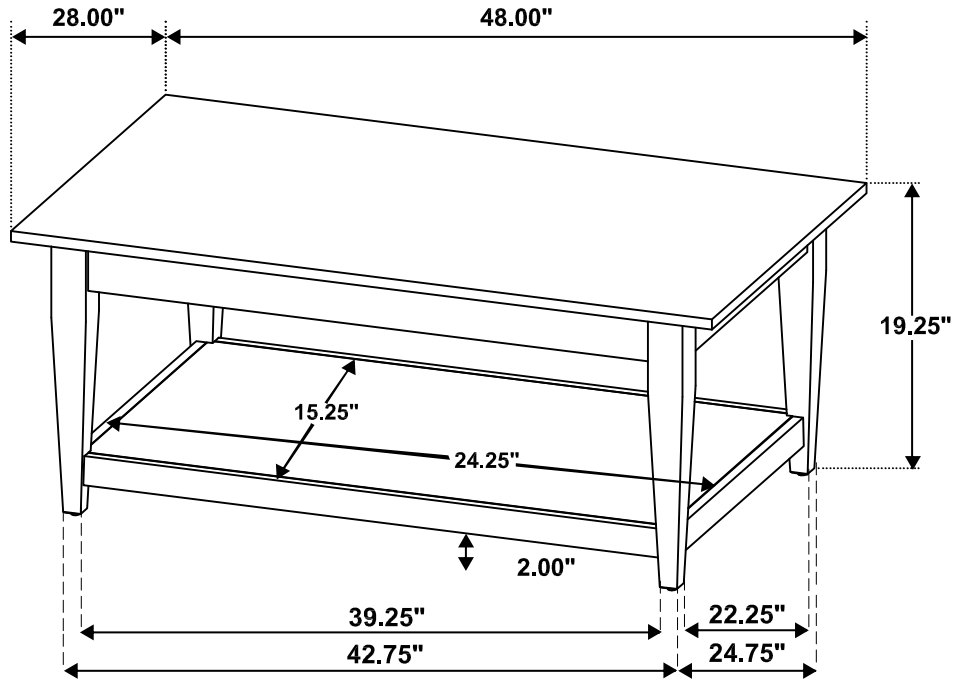

Note: Dimension tolerance $\pm 5\%$