

*ASSEMBLY INSTRUCTIONS*  
*COASTER FINE FURNITURE*



*Fine Furniture for every stage of life*

**722827**  
**End Table**

# ITEM: 722827



## ASSEMBLY INSTRUCTIONS

### ASSEMBLY TIPS:

1. Remove hardware from box and sort by size.
2. Please check to see that all hardware and parts are present prior to start of assembly.
3. Please follow attached instructions in the same sequence as numbered to assure fast & easy assembly.



### WARNING!

1. Don't attempt to repair or modify parts that are broken or defective. Please contact the store immediately.
2. This product is for home use only and not intended for commercial establishments.





ASSEMBLY TIME

15 MINUTES

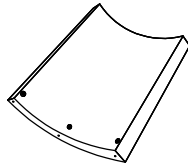
## PARTS IDENTIFICATION

A	TOP		1PC
B	LEG		2PCS

## HARDWARE IDENTIFICATION

1	<b>CAM BOLT</b> (5534-885-300 - ZB)		6PCS
2	<b>CAM NUT</b> (5656-885-300 - ZB)		6PCS
3	<b>LEVELER</b> (M6 x 14.8mm)		4PCS

ITEM: **722827**

**ASSEMBLY INSTRUCTIONS**



**STEP 1**

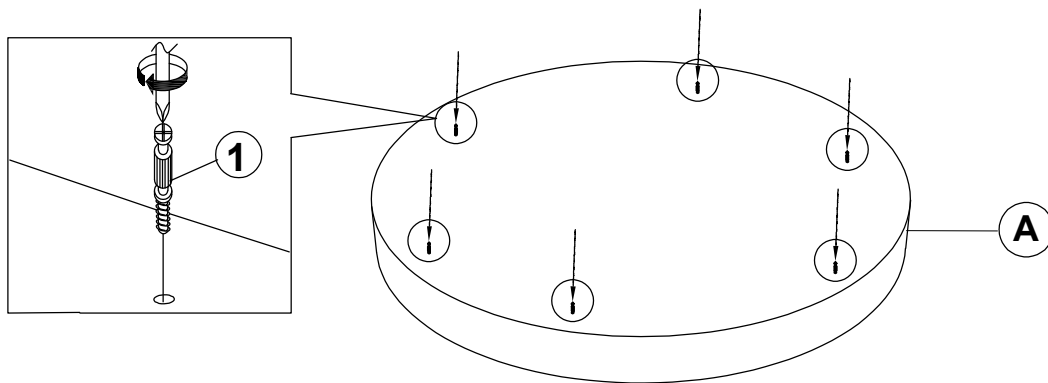
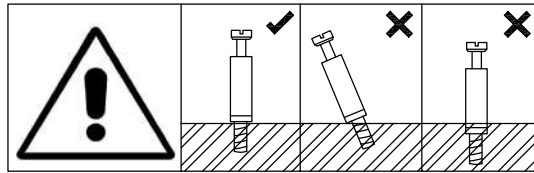

**STEP 2**

Make sure the arrow on each cam nut points toward the cam bolt it will secure.

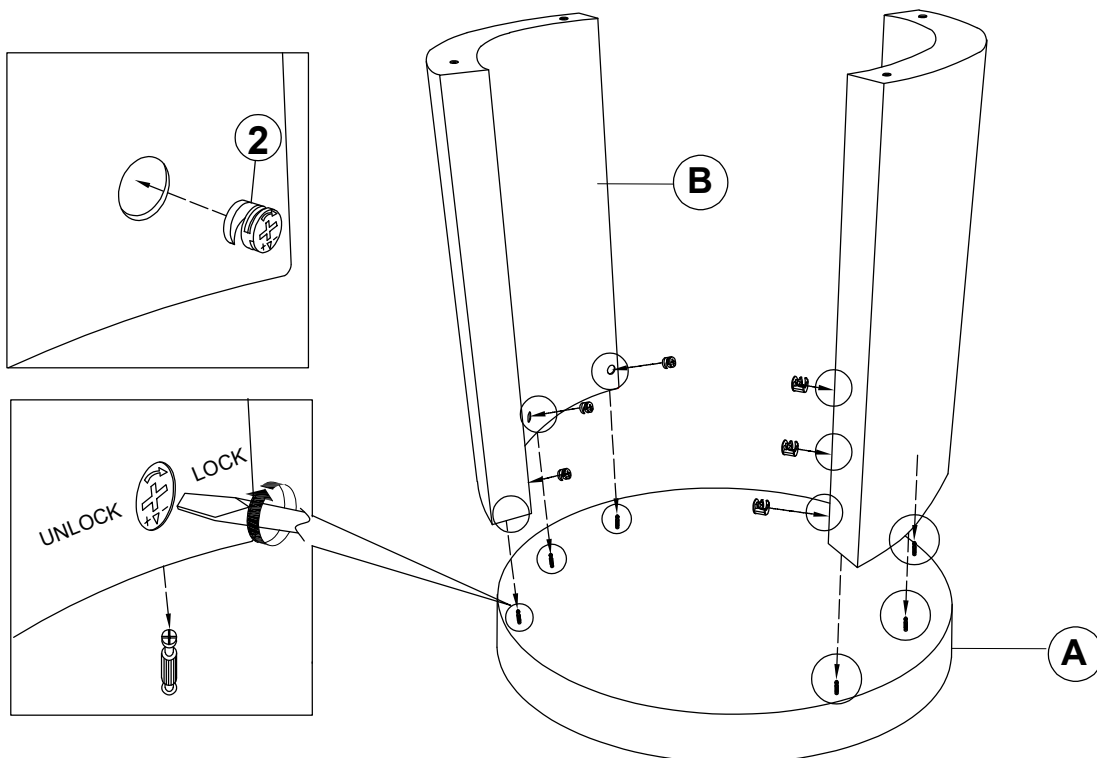

ITEM: **722827**

**ASSEMBLY INSTRUCTIONS**



**STEP 3**

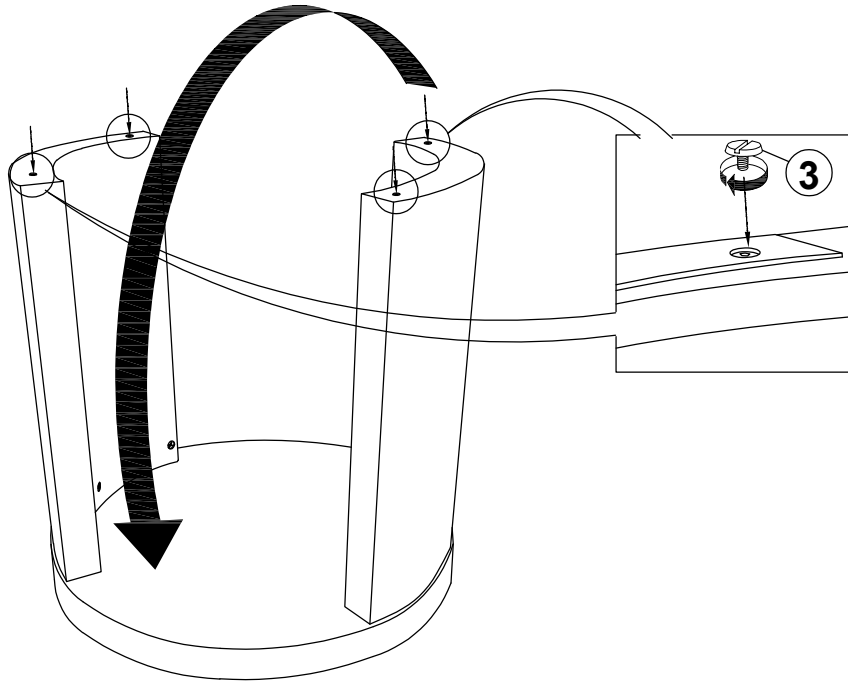

**STEP 4**  
**COMPLETE**

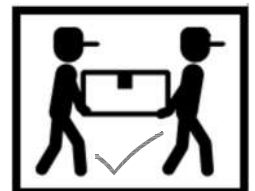
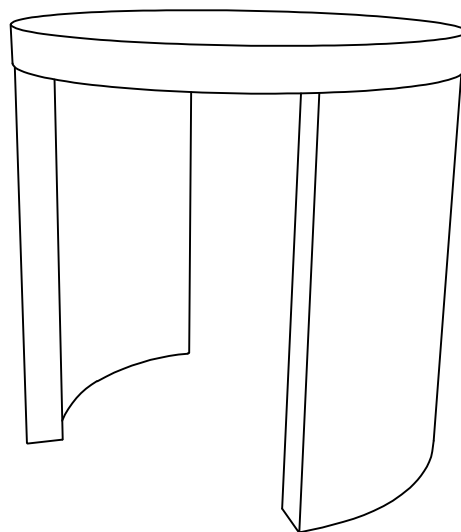

ITEM: **722827**

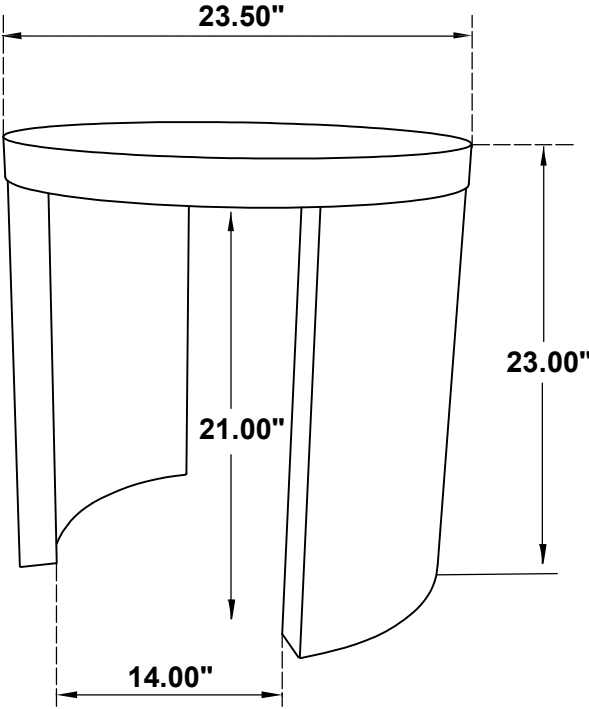

**Note: Dimension tolerance  $\pm 5\%$**

***ASSEMBLY INSTRUCTIONS***  
***COASTER FINE FURNITURE***



*Fine Furniture for every stage of life*

**722828**  
**Coffee Table**



ITEM: **722828**

**ASSEMBLY INSTRUCTIONS**



**STEP 1**

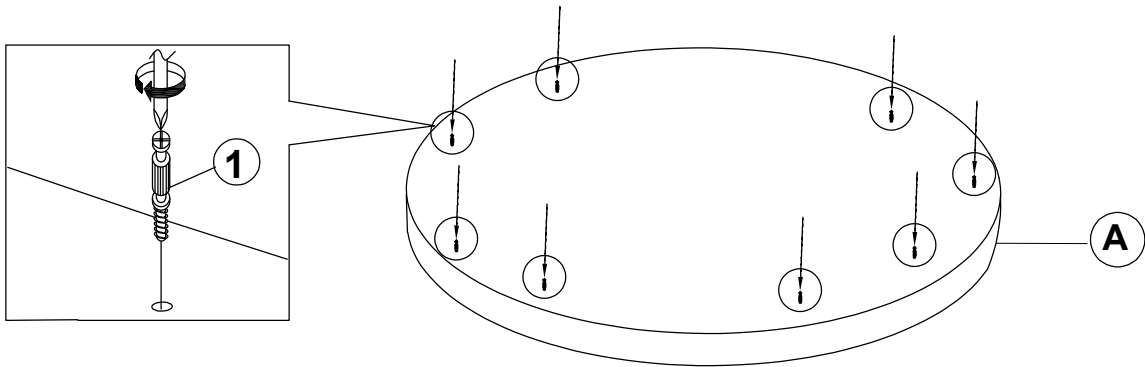
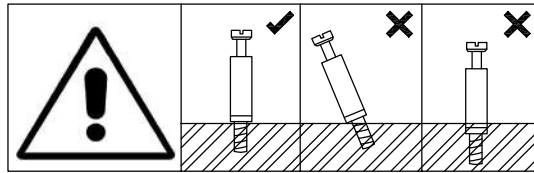

**STEP 2**

Make sure the arrow on each cam nut points toward the cam bolt it will secure.

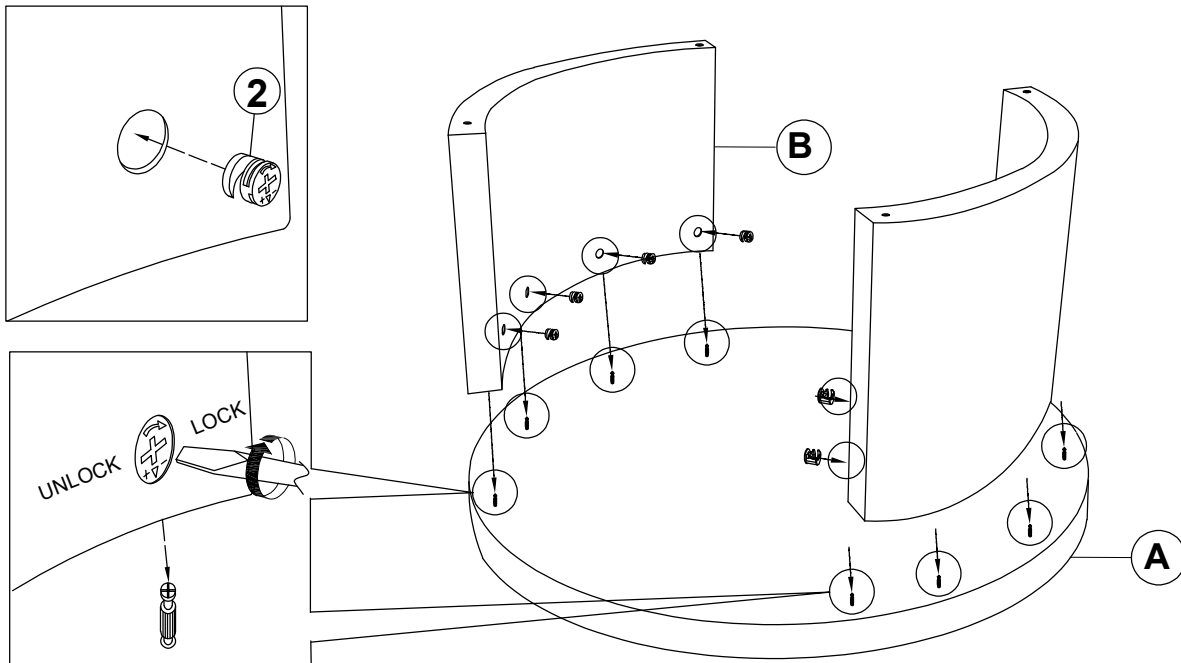

ITEM: **722828**

**ASSEMBLY INSTRUCTIONS**



**STEP 3**

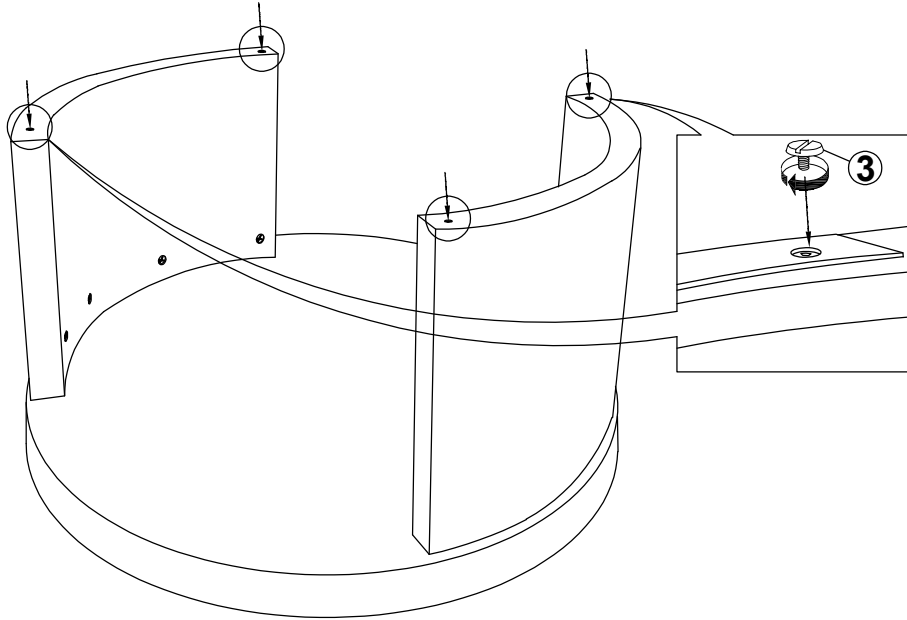

**STEP 4**  
**COMPLETE**

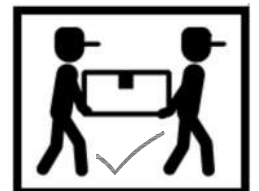
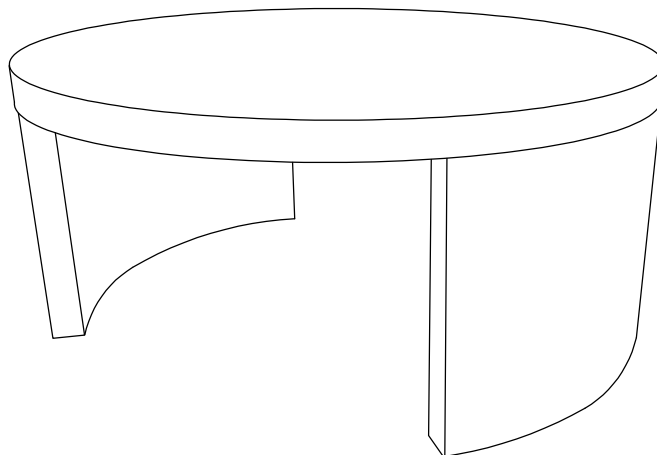

ITEM: **722828**

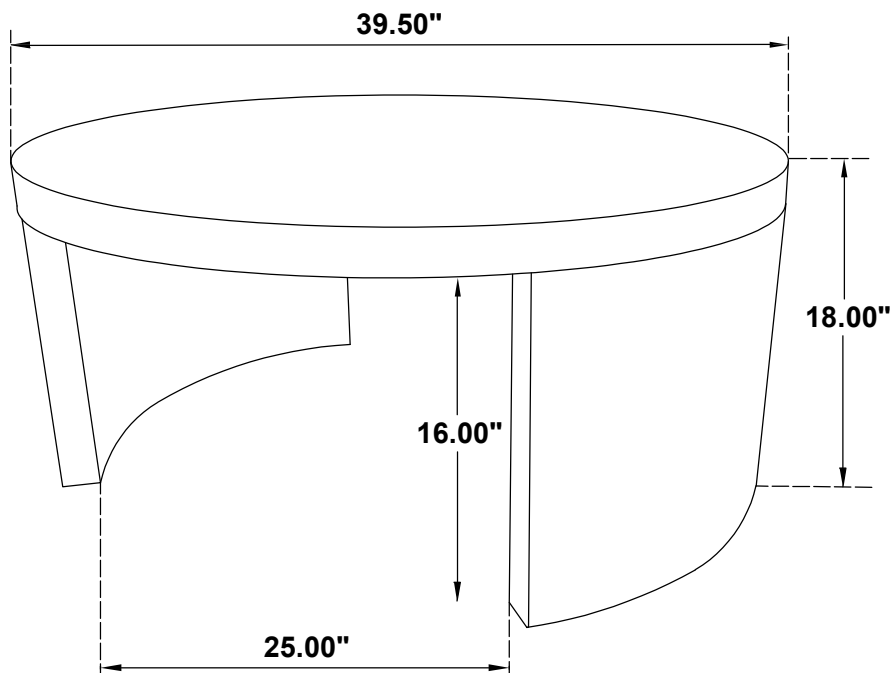

**Note: Dimension tolerance  $\pm 5\%$**