

*ASSEMBLY INSTRUCTIONS*  
*COASTER FINE FURNITURE*



*Fine Furniture for every stage of life*

**801115 (B1&B2)**  
***Writing Desk***

# ITEM: 801115 (B1&B2)



## ASSEMBLY INSTRUCTIONS

### ASSEMBLY TIPS:

1. Remove hardware from box and sort by size.
2. Please check to see that all hardware and parts are present prior to start of assembly.
3. Please follow attached instructions in the same sequence as numbered to assure fast & easy assembly.



### WARNING!

1. Don't attempt to repair or modify parts that are broken or defective. Please contact the store immediately.
2. This product is for home use only and not intended for commercial establishments.







ASSEMBLY TIME

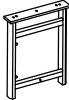

30 MINUTES

## PARTS IDENTIFICATION

### B1 (BOX 1)

A	DESK TOP		1PC
B	SIDE LEG FRAME		2PCS
C	LEFT FRONT LEG FRAME		1PC
D	RIGHT FRONT LEG FRAME		1PC
E	BACK PANEL		1PC

### B2 (BOX 2)

F	LEFT DRAWER UNIT		1PC
G	RIGHT DRAWER UNIT		1PC
H	FLAT SUPPORT BAR		2PCS

# ITEM: 801115 (B1&B2)



## ASSEMBLY INSTRUCTIONS

### ASSEMBLY TIPS:

1. Remove hardware from box and sort by size.
2. Please check to see that all hardware and parts are present prior to start of assembly.
3. Please follow attached instructions in the same sequence as numbered to assure fast & easy assembly.









### WARNING!

1. Don't attempt to repair or modify parts that are broken or defective. Please contact the store immediately.
2. This product is for home use only and not intended for commercial establishments.

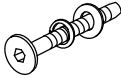
## HARDWARE IDENTIFICATION

### Z-B1 (BOX 1) - HARDWARE PACK IS LOCATED IN 801115 (B1)

1	<b>ALLEN WRENCH</b> (M4 x 110mm - BLK)		1PC
2	<b>SHORT BOLT WITH WASHER</b> (M6 x 35mm - BLK)		10PCS
3	<b>LONG BOLT WITH WASHER</b> (M6 x 50mm - BLK)		8PCS
4	<b>WOOD DOWEL</b> (M10 x 30mm)		6PCS
5	<b>PAN HEAD SCREW</b> (M4 x 16mm - BLK)		4PCS
6	<b>CLIP</b>		4PCS

### NOTE:

Phillips head screw driver is required in the assembly process; however, manufacturer does not provide this item.

# ITEM: 801115 (B1&B2)



## ASSEMBLY INSTRUCTIONS

### STEP 1

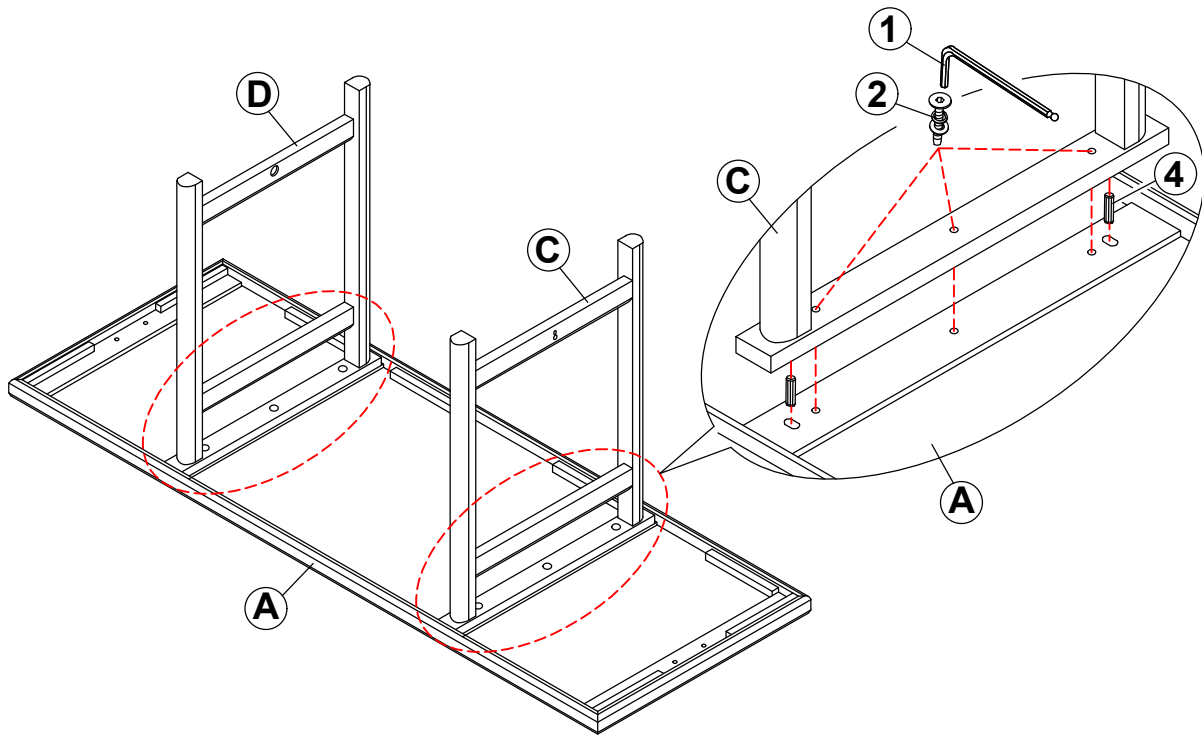

### STEP 2

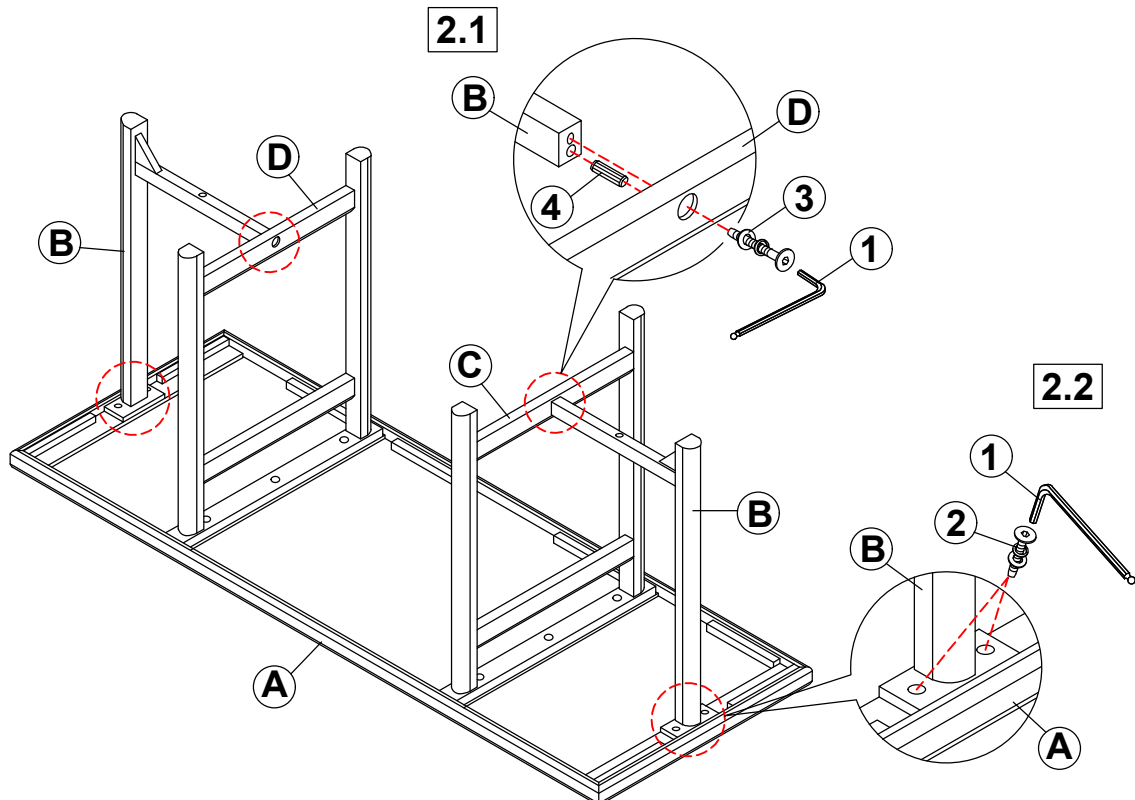

ITEM: **801115 (B1&B2)**



**ASSEMBLY INSTRUCTIONS**

**STEP 3**

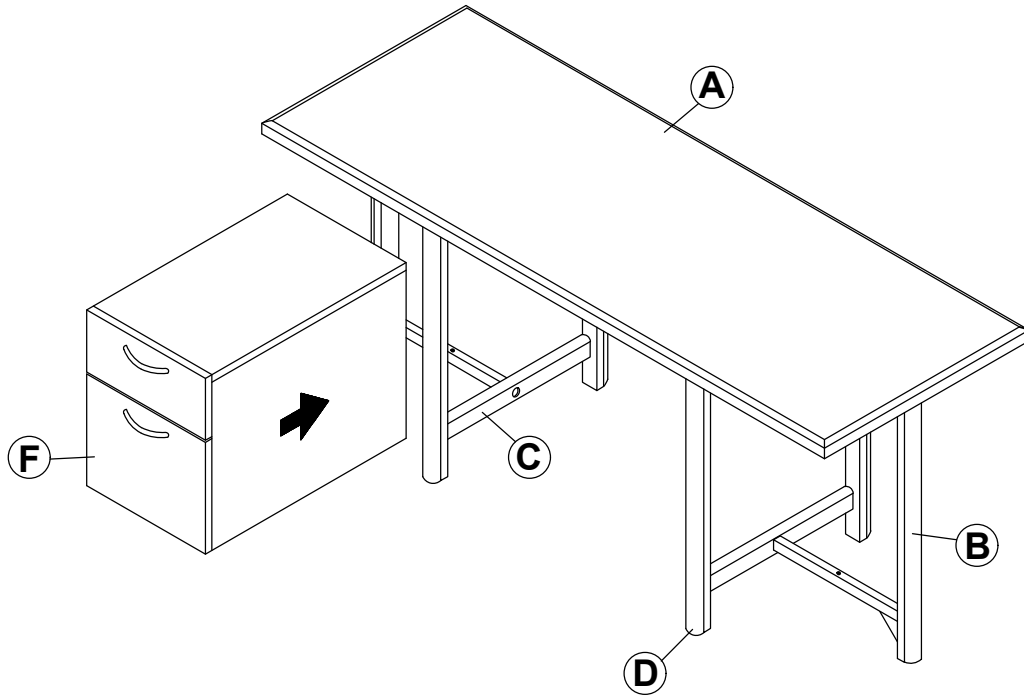

**STEP 4**

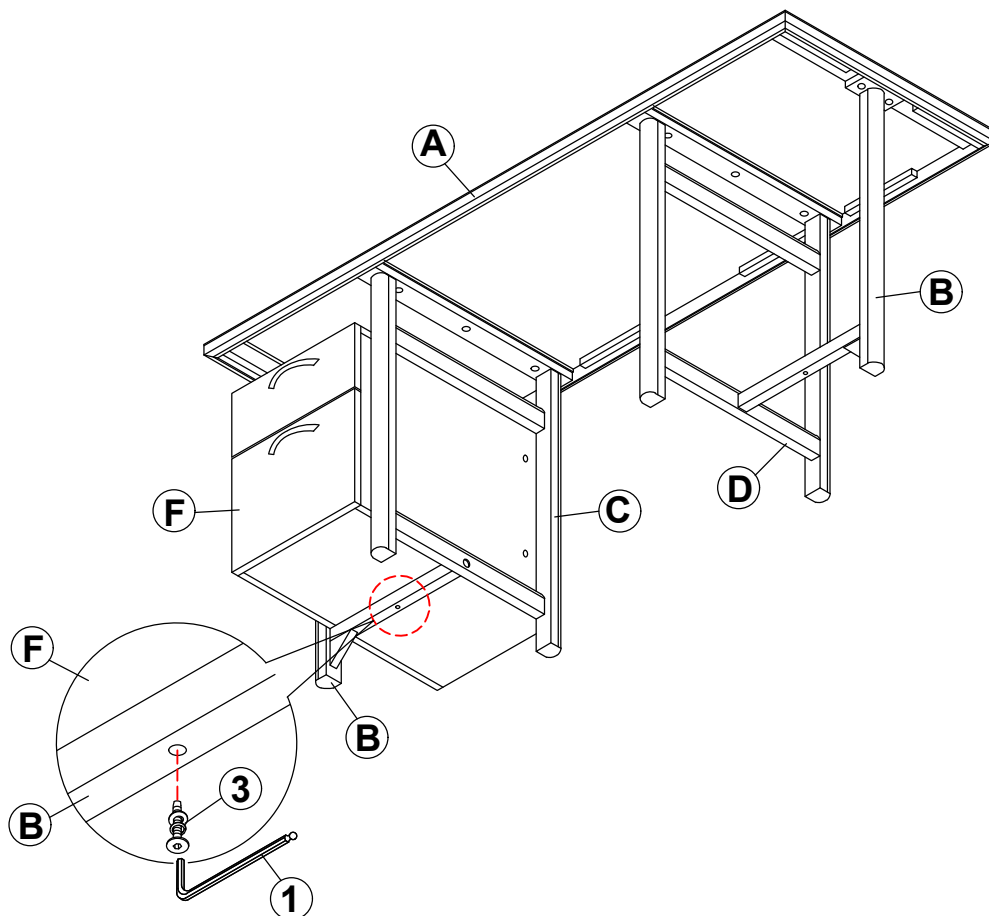

ITEM: **801115 (B1&B2)**



**ASSEMBLY INSTRUCTIONS**  
**STEP 5**

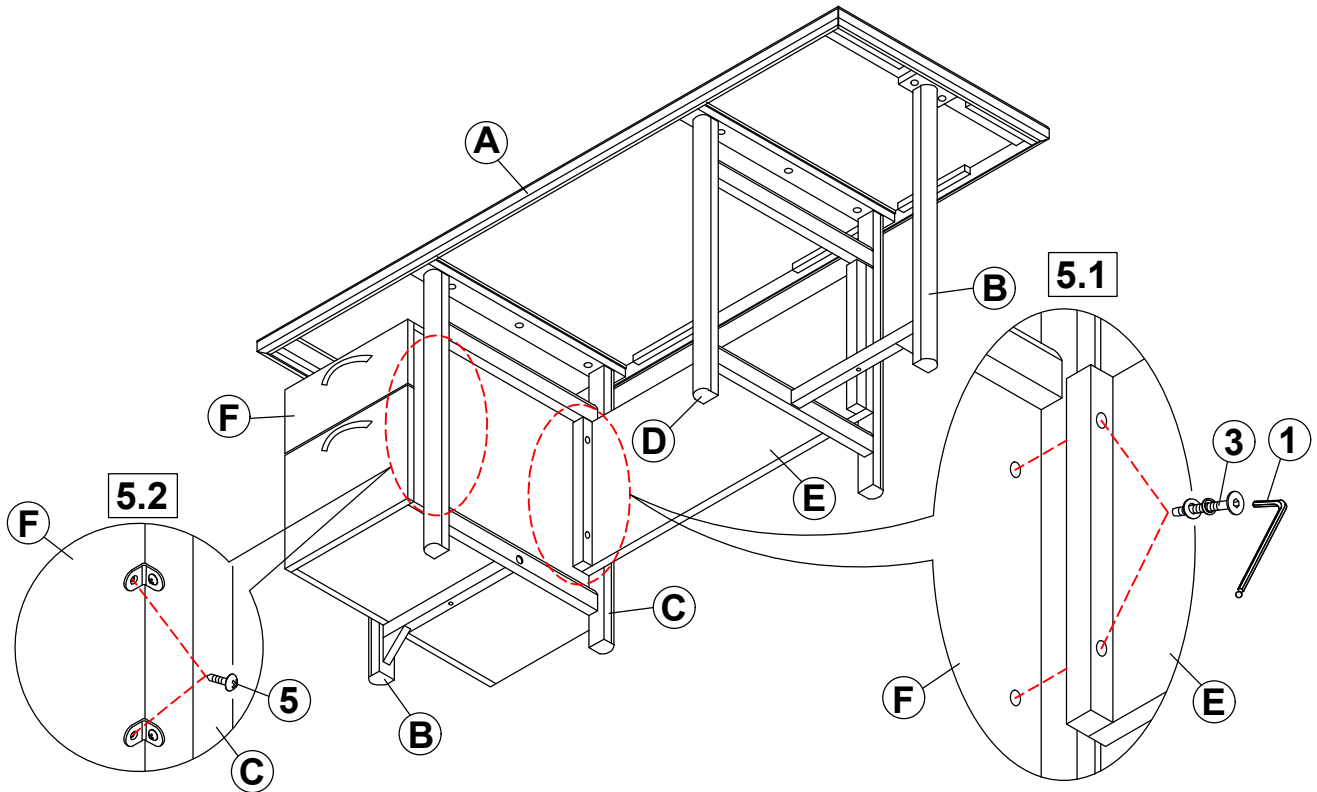

**STEP 6**

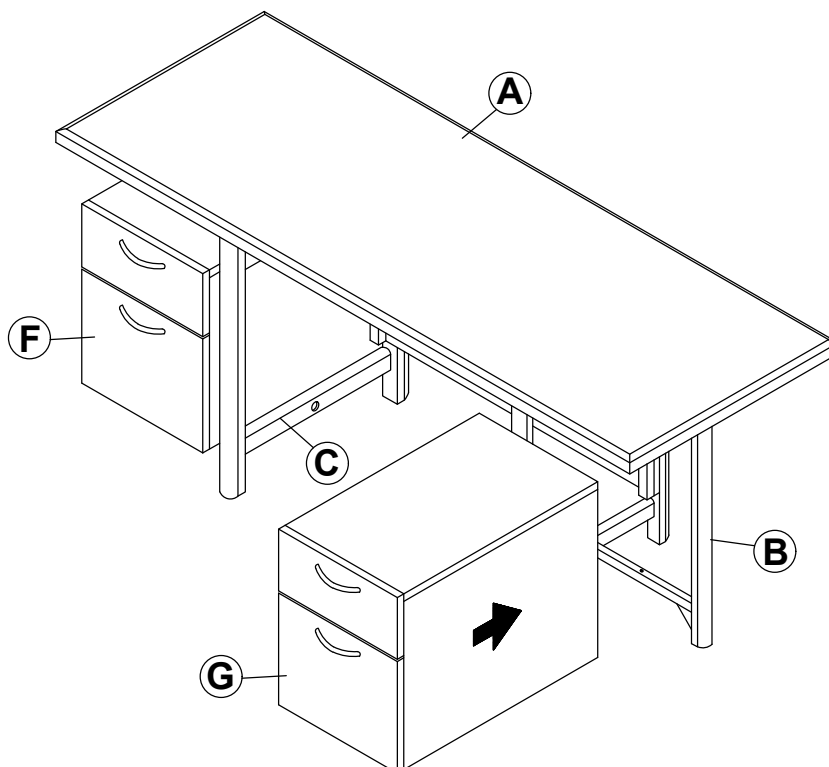

ITEM: **801115 (B1&B2)**



**ASSEMBLY INSTRUCTIONS**

**STEP 7**

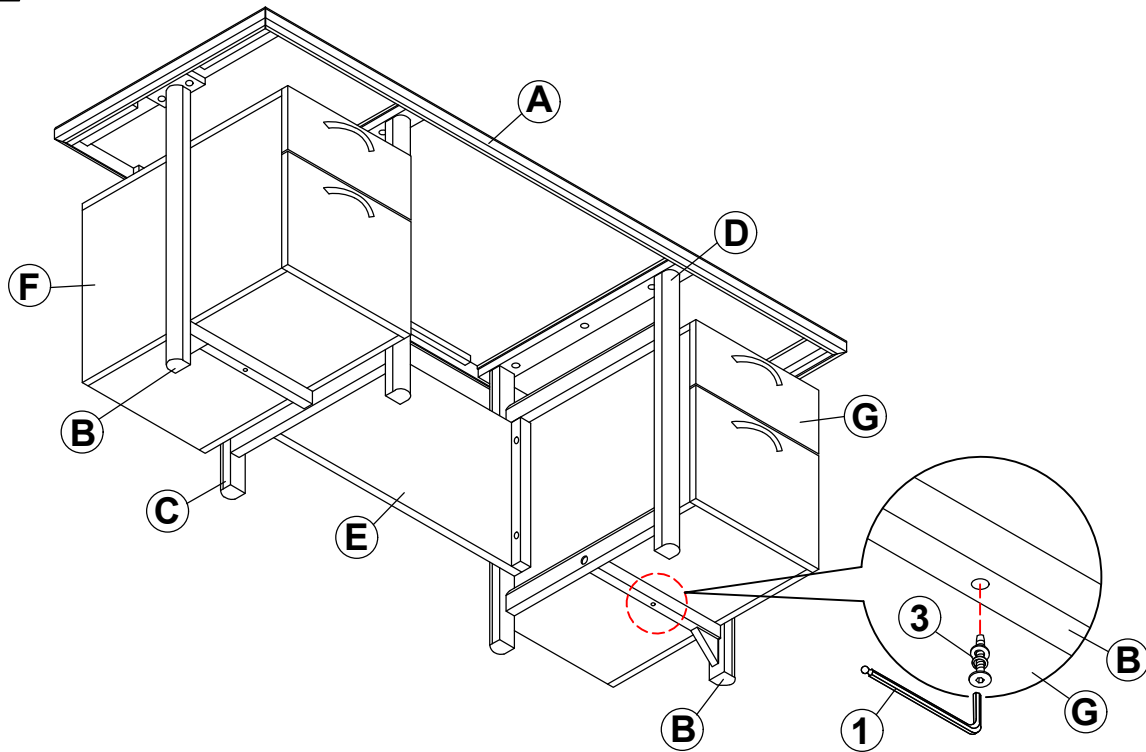

**STEP 8**

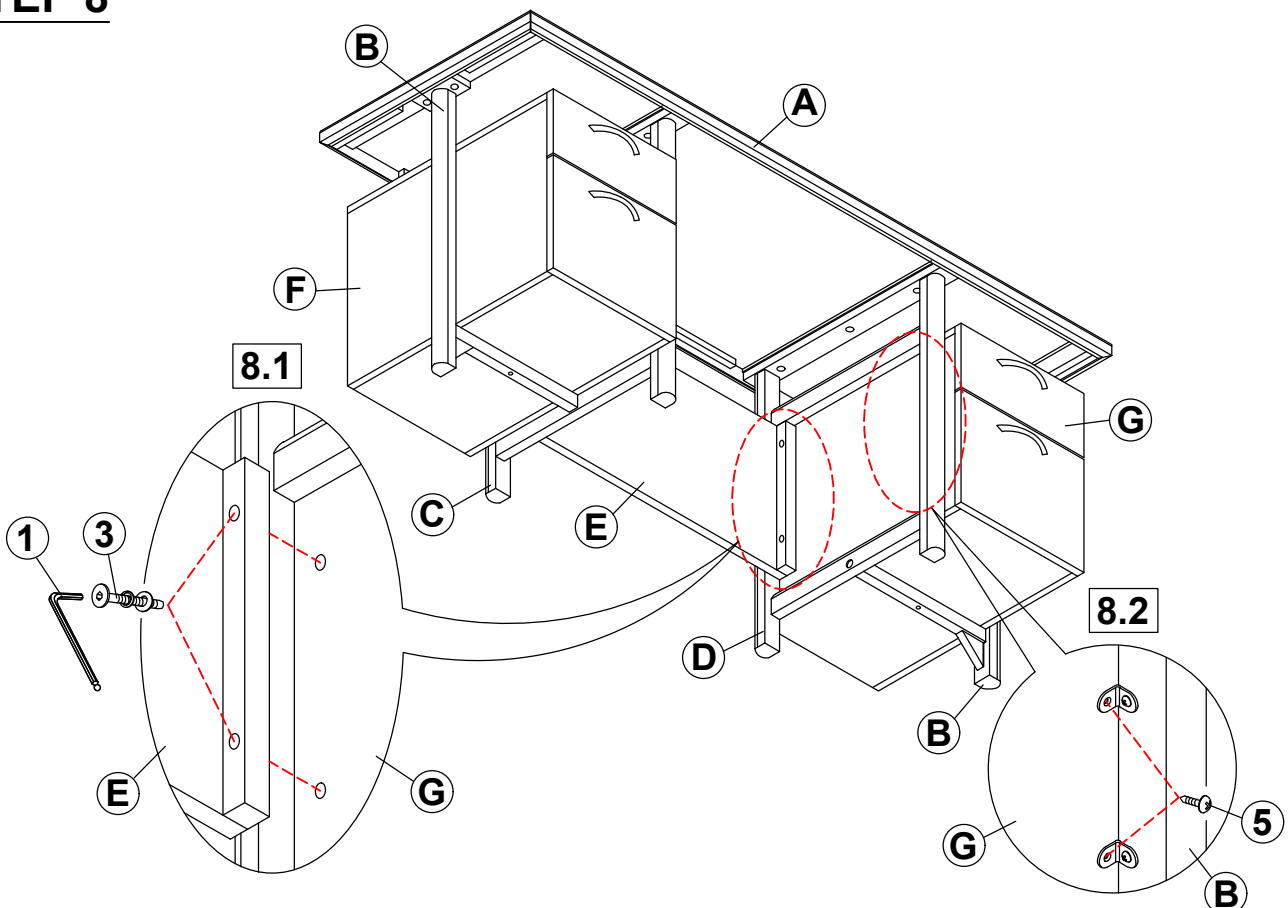

ITEM: **801115 (B1&B2)**



**ASSEMBLY INSTRUCTIONS**

**STEP 9**

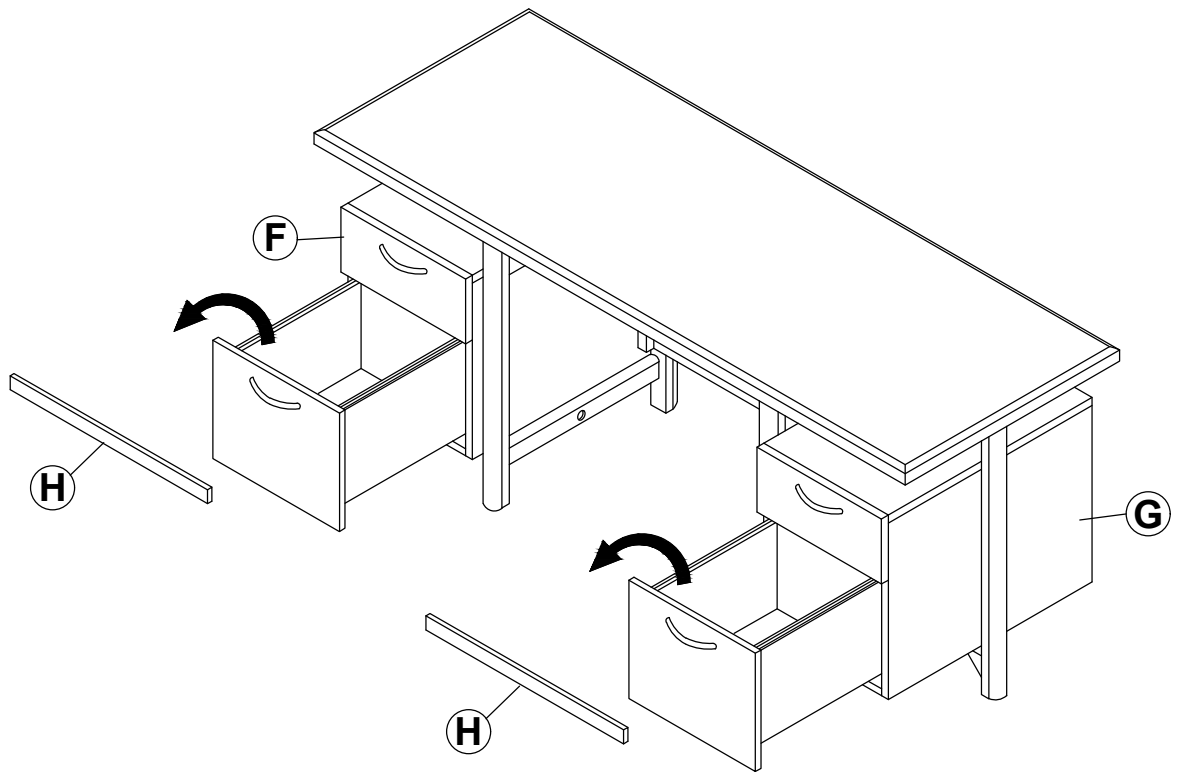

**STEP 10**

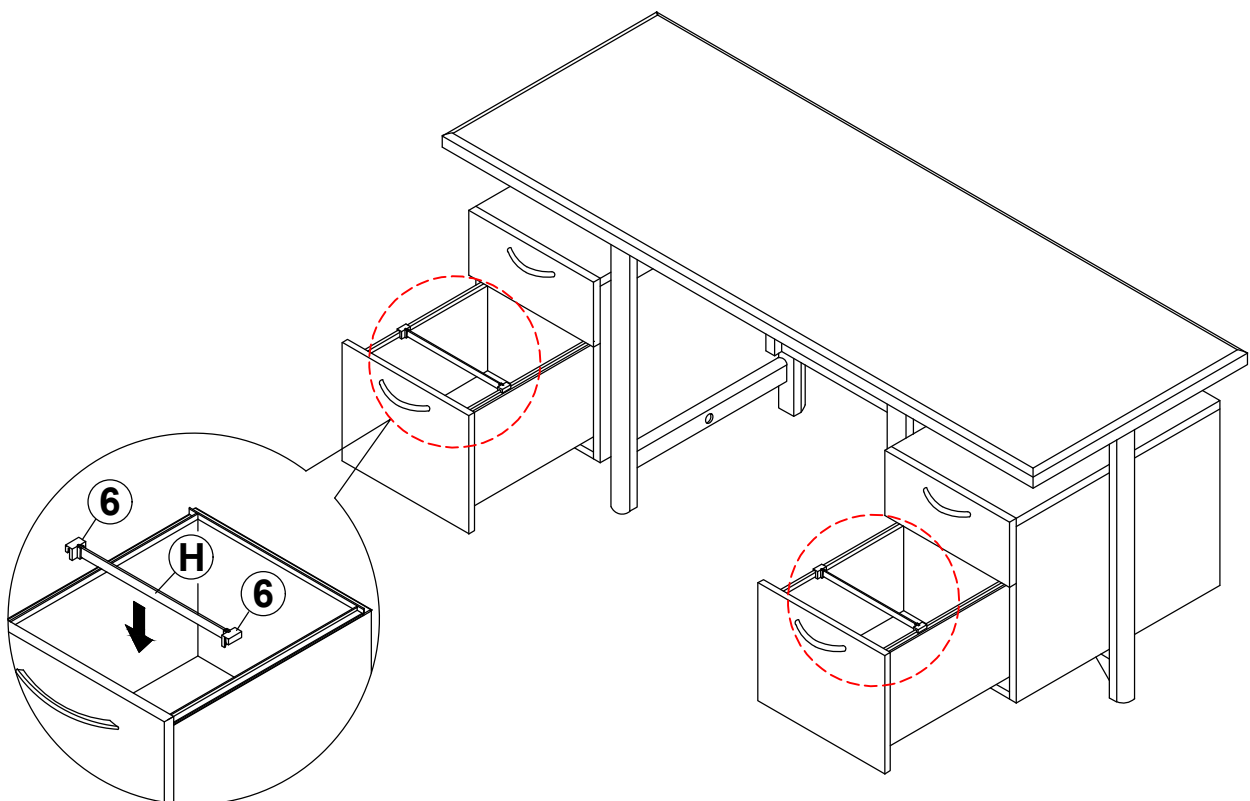

ITEM: **801115 (B1&B2)**

**ASSEMBLY INSTRUCTIONS**

**STEP 11**

**COMPLETE**

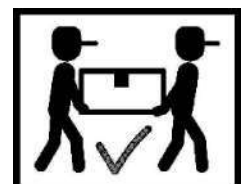
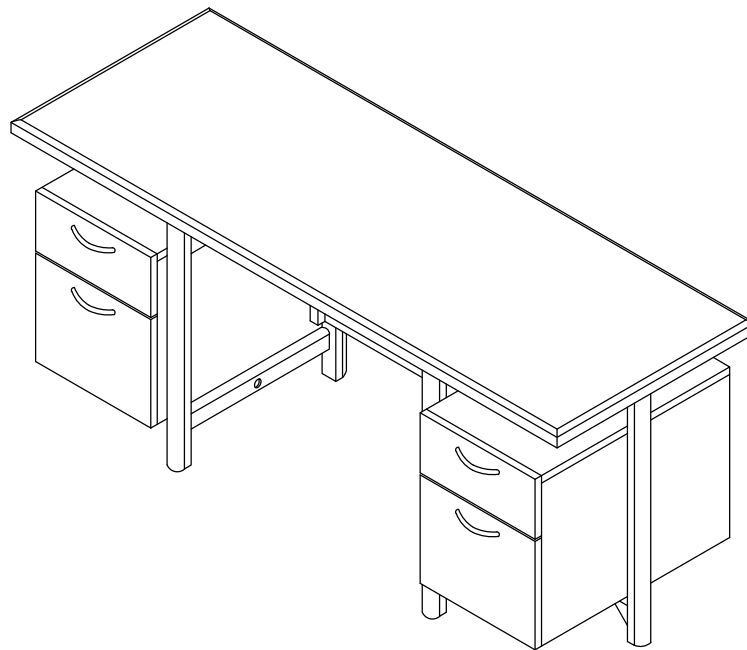

# ITEM: 801115 (B1&B2)



Inner Size of Drawer A : 11.50"W x 14.00"D x 4.00"H x 0.50"T  
Inner Size of Drawer B : 11.50"W x 14.00"D x 8.50"H x 0.50"T

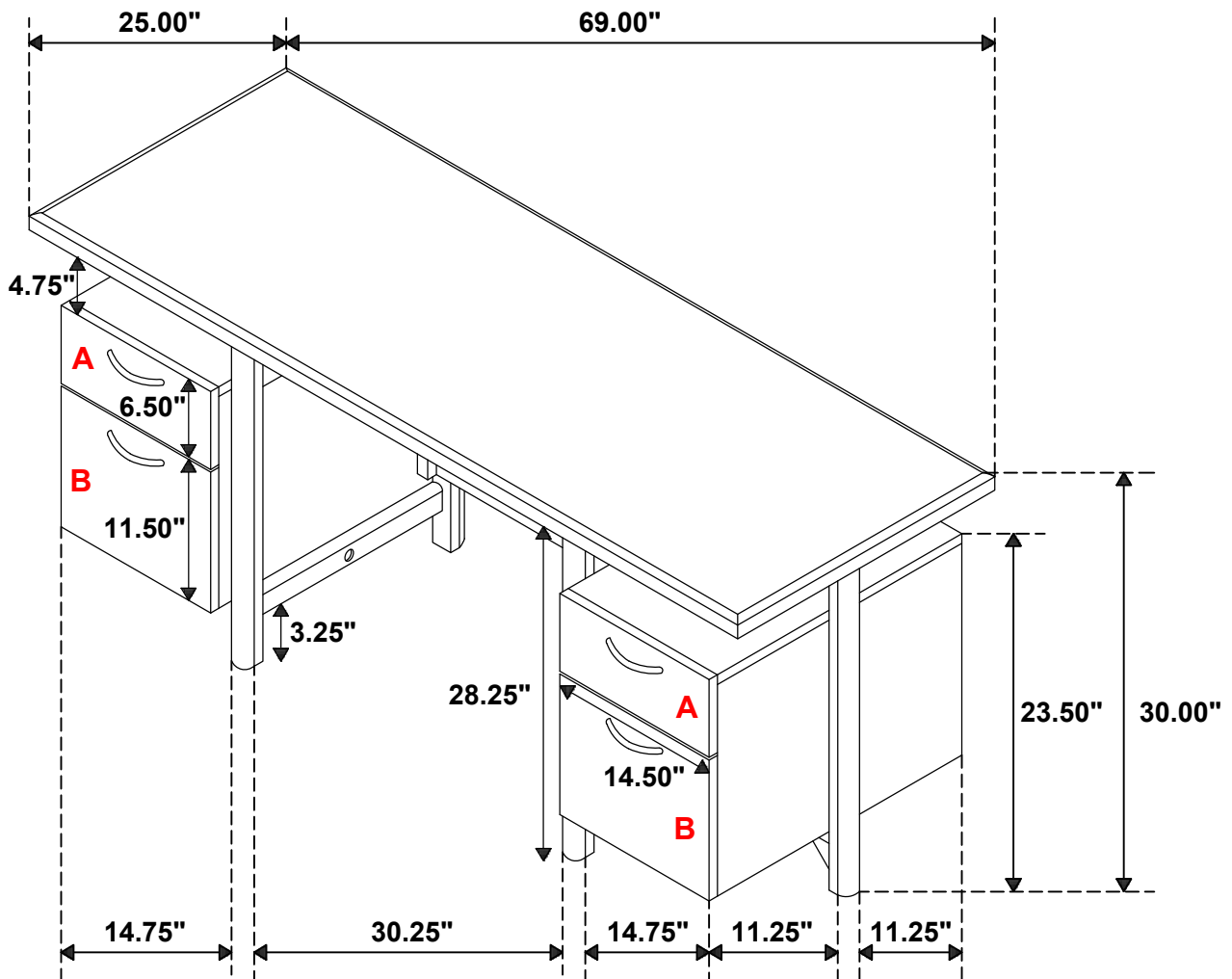

Note : Dimension tolerance  $\pm 5\%$