

*ASSEMBLY INSTRUCTIONS*  
*COASTER FINE FURNITURE*



*Fine Furniture for every stage of life*

**801586 (B1&B2)**  
***Writing Desk***

# ITEM: 801586 (B1&B2)



## ASSEMBLY INSTRUCTIONS

### ASSEMBLY TIPS:

1. Remove hardware from box and sort by size.
2. Please check to see that all hardware and parts are present prior to start of assembly.
3. Please follow attached instructions in the same sequence as numbered to assure fast & easy assembly.



### WARNING!

1. Don't attempt to repair or modify parts that are broken or defective. Please contact the store immediately.
2. This product is for home use only and not intended for commercial establishments.







ASSEMBLY TIME

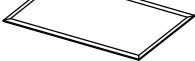
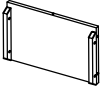

30 MINUTES

## PARTS IDENTIFICATION

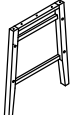
### B1 (BOX 1)

A	DESK TOP		1PC
B	BACK PANEL		1PC
C	BOTTOM PANEL		1PC
D	SIDE PANEL		2PCS
E	CENTER TOP PANEL		1PC
F	LEG FRAME		2PCS

### B2 (BOX 2)

G	LEFT DRAWER UNIT		1PC
H	RIGHT DRAWER UNIT		1PC
I	FLAT SUPPORT BAR		2PCS

# ITEM: 801586 (B1&B2)



## ASSEMBLY INSTRUCTIONS

### ASSEMBLY TIPS:

1. Remove hardware from box and sort by size.
2. Please check to see that all hardware and parts are present prior to start of assembly.
3. Please follow attached instructions in the same sequence as numbered to assure fast & easy assembly.









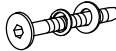
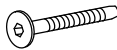

### WARNING!

1. Don't attempt to repair or modify parts that are broken or defective. Please contact the store immediately.
2. This product is for home use only and not intended for commercial establishments.

## HARDWARE IDENTIFICATION

### Z-B1 (BOX 1) - HARDWARE PACK IS LOCATED IN 801586 (B1)

1	<b>ALLEN WRENCH</b> (M4 x 110mm - BLK)		1PC
2	<b>SHORT BOLT WITH WASHER</b> (M6 x 35mm - BLK)		6PCS
3	<b>LONG BOLT WITH WASHER</b> (M6 x 50mm - BLK)		10PCS
4	<b>LONG BOLT</b> (M6 x 50mm - BLK)		12PCS
5	<b>WOOD DOWEL</b> (M8 x 30mm)		30PCS
6	<b>WOOD BUTTON</b> (M14.3 x 9mm)		8PCS
7	<b>CAM BOLT</b> (T24 - BLK)		14PCS
8	<b>CAM NUT</b> (D15 x 9.5mm - BLK)		14PCS
9	<b>CLIP</b>		4PCS

### NOTE:

Phillips head screw driver is required in the assembly process; however, manufacturer does not provide this item.

ITEM: **801586 (B1&B2)**



**ASSEMBLY INSTRUCTIONS**

**STEP 1**

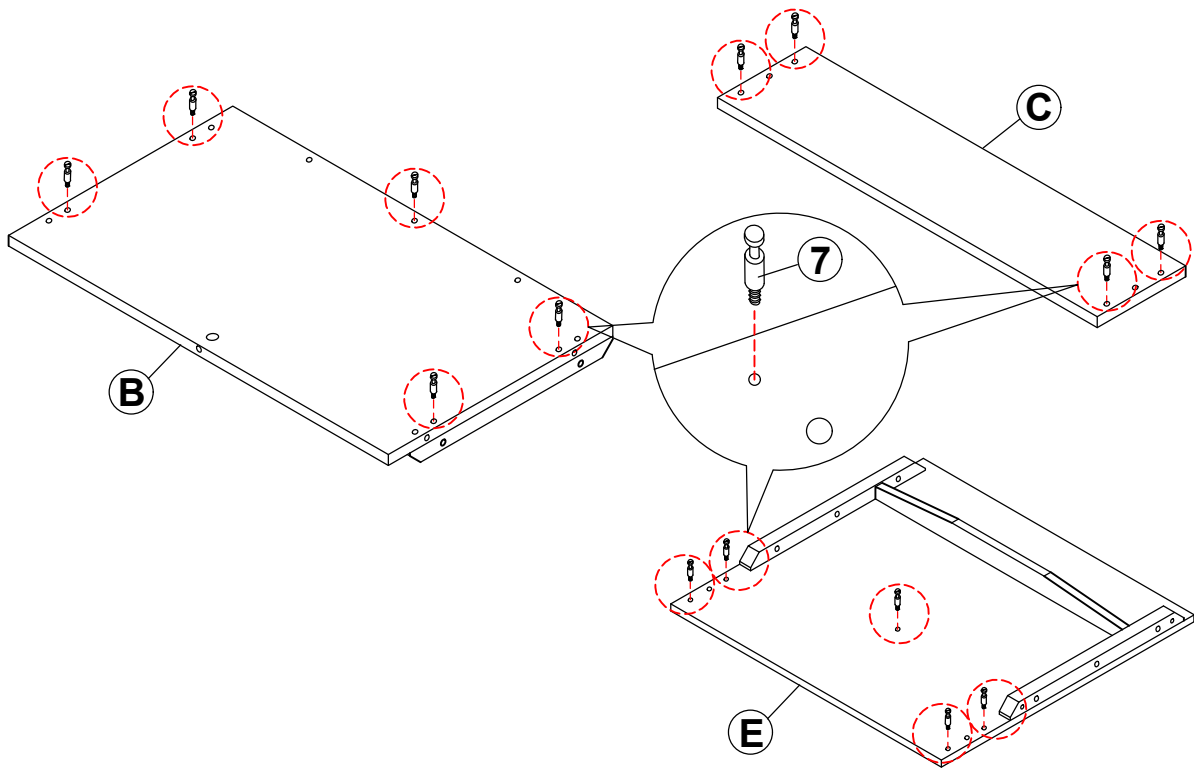

**STEP 2**

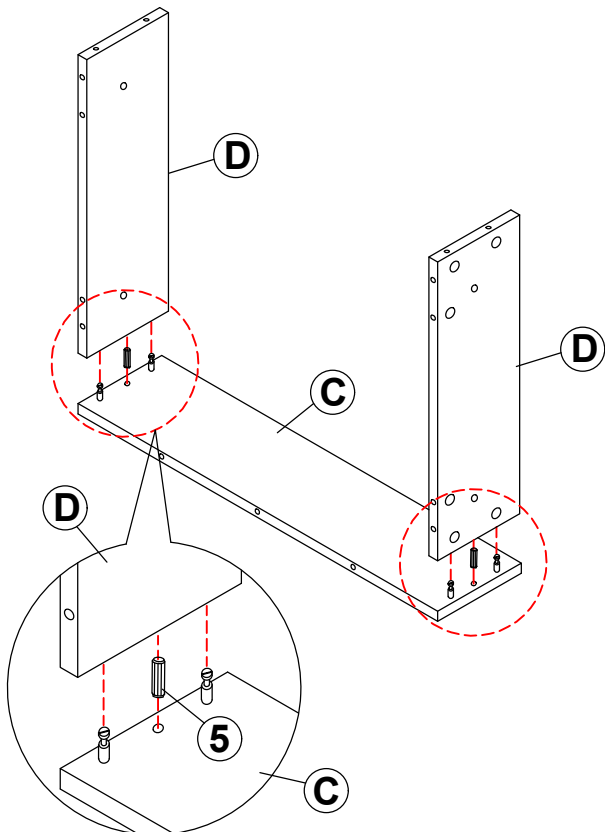

**STEP 3**

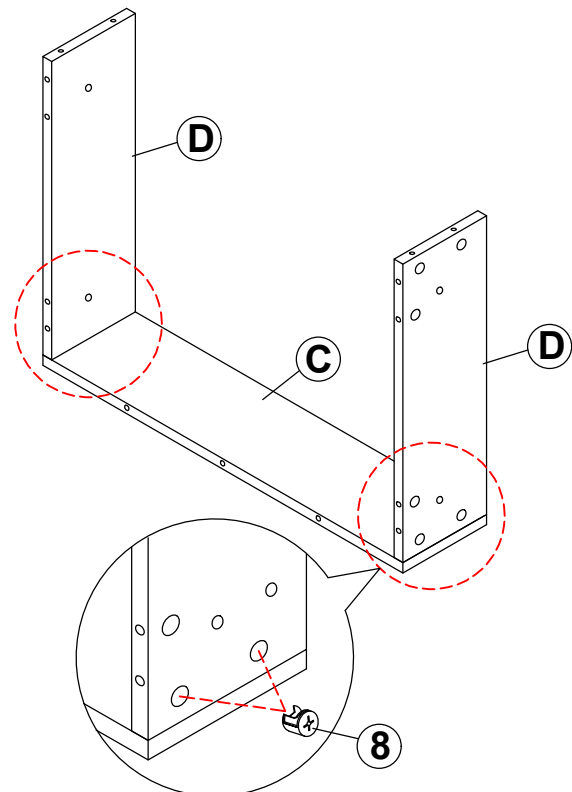

ITEM: **801586 (B1&B2)**



**ASSEMBLY INSTRUCTIONS**

**STEP 4**

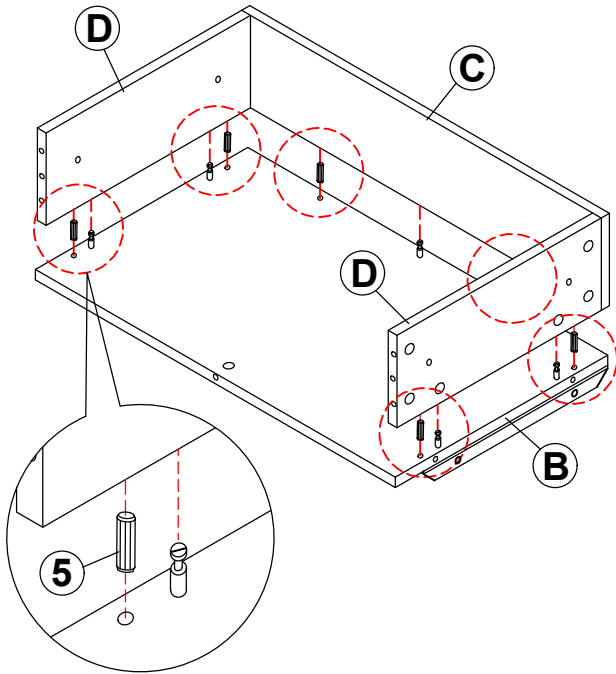

**STEP 5**

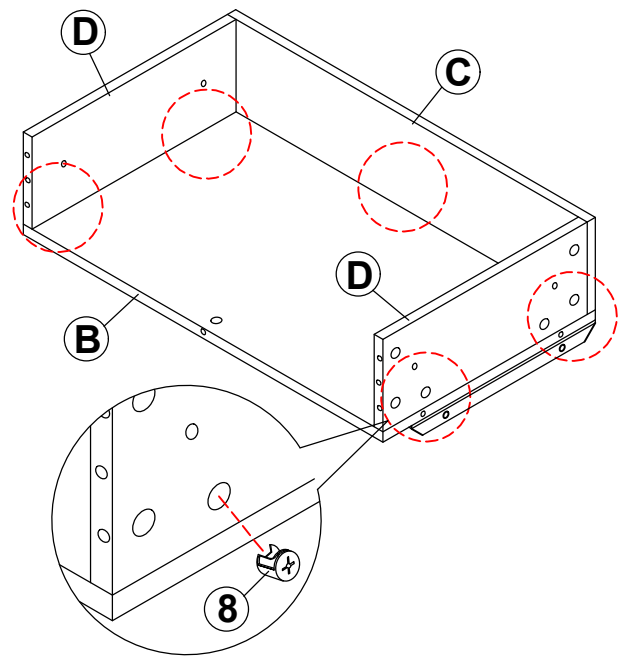

**STEP 6**

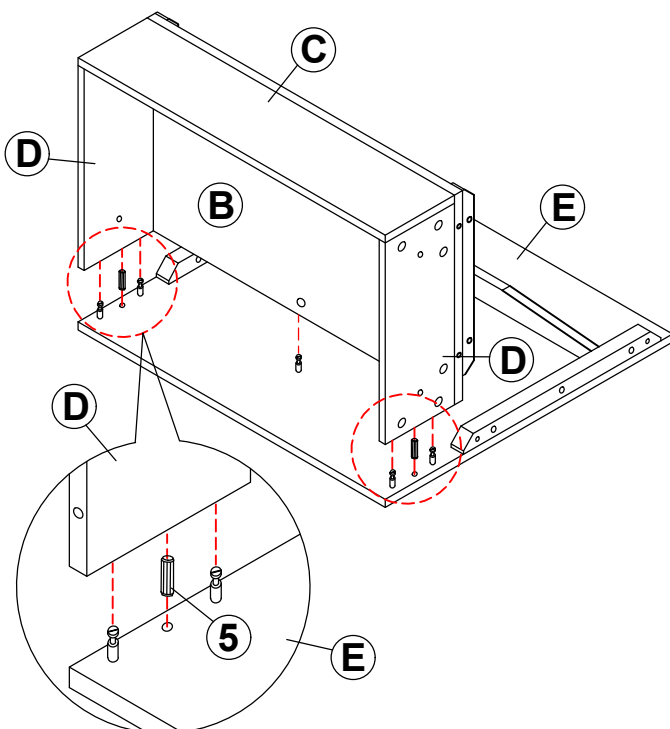

**STEP 7**

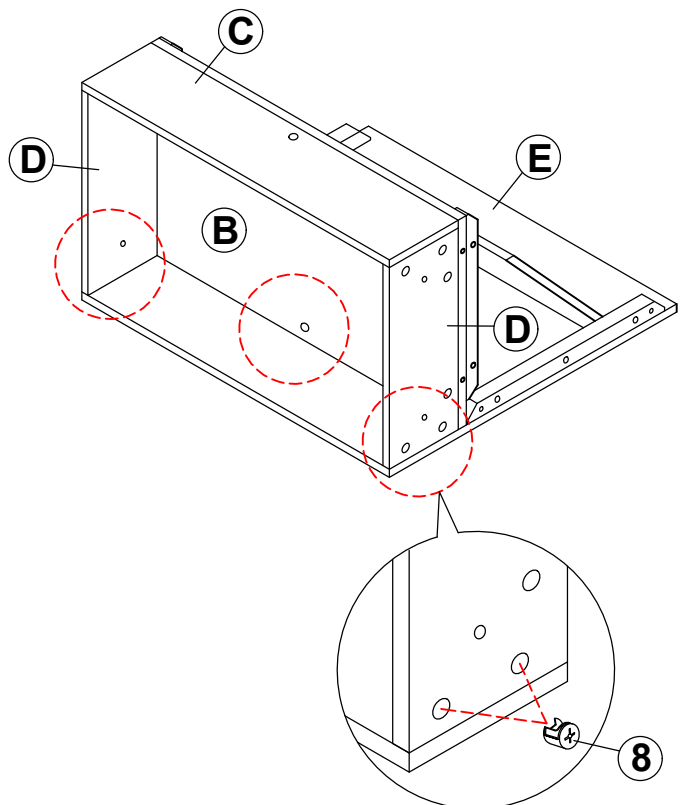

ITEM: **801586 (B1&B2)**



**ASSEMBLY INSTRUCTIONS**

**STEP 8**

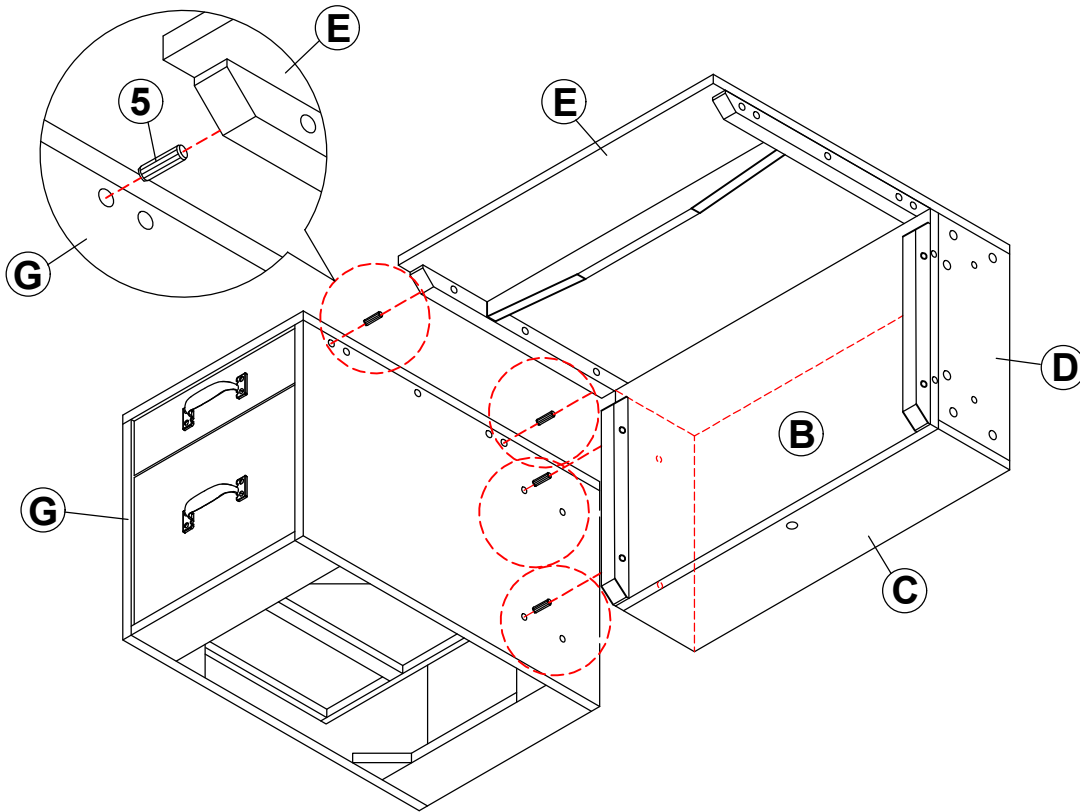

**STEP 9**

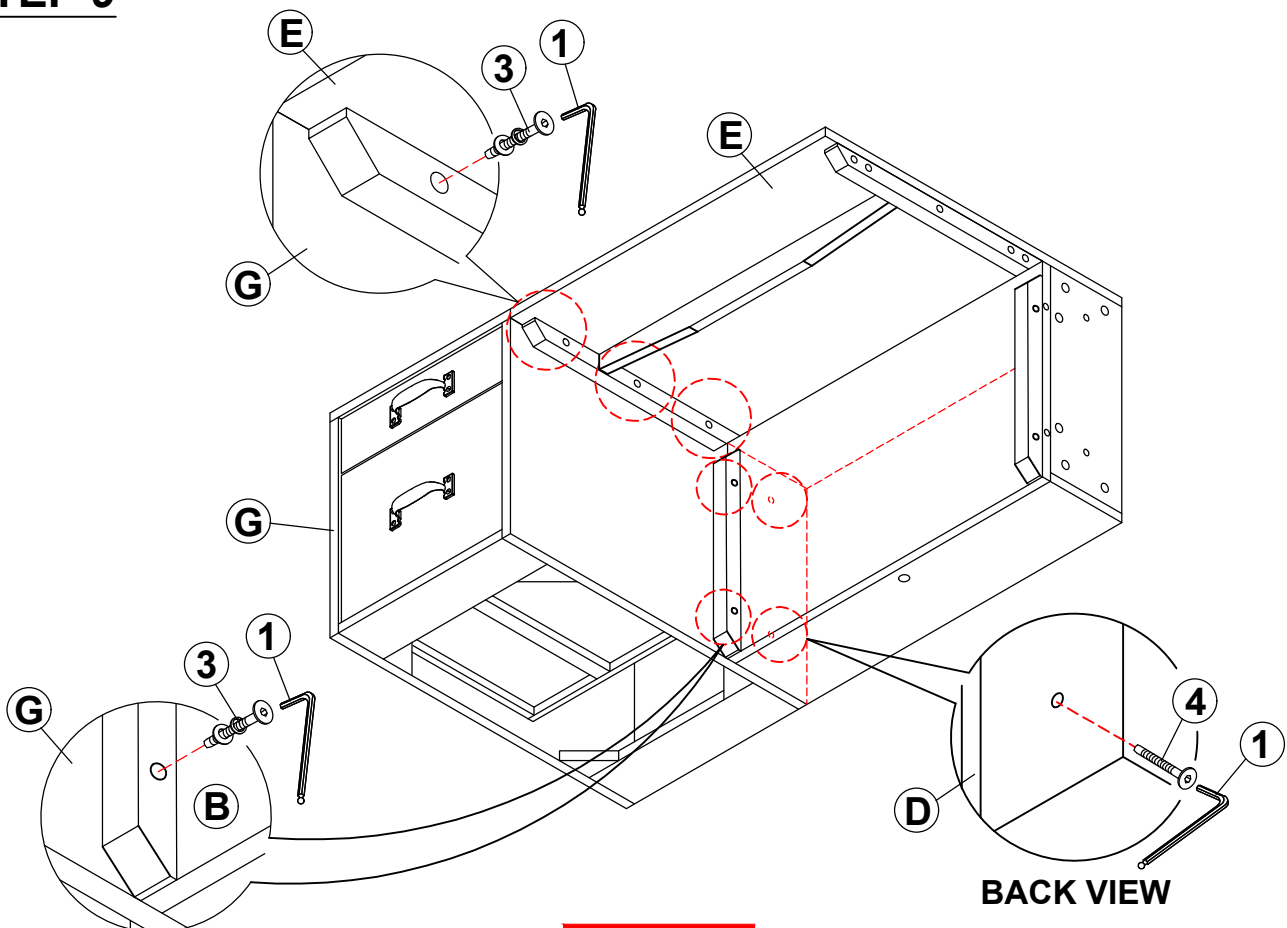

ITEM: **801586 (B1&B2)**



**ASSEMBLY INSTRUCTIONS**

**STEP 10**

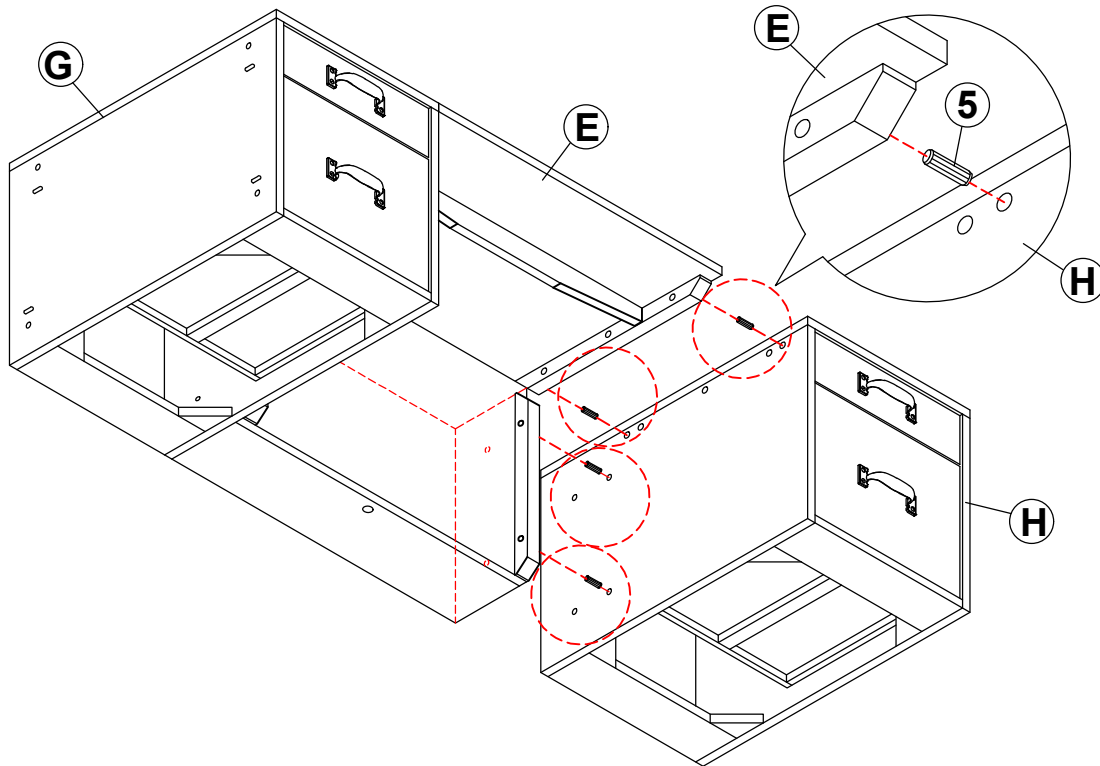

**STEP 11**

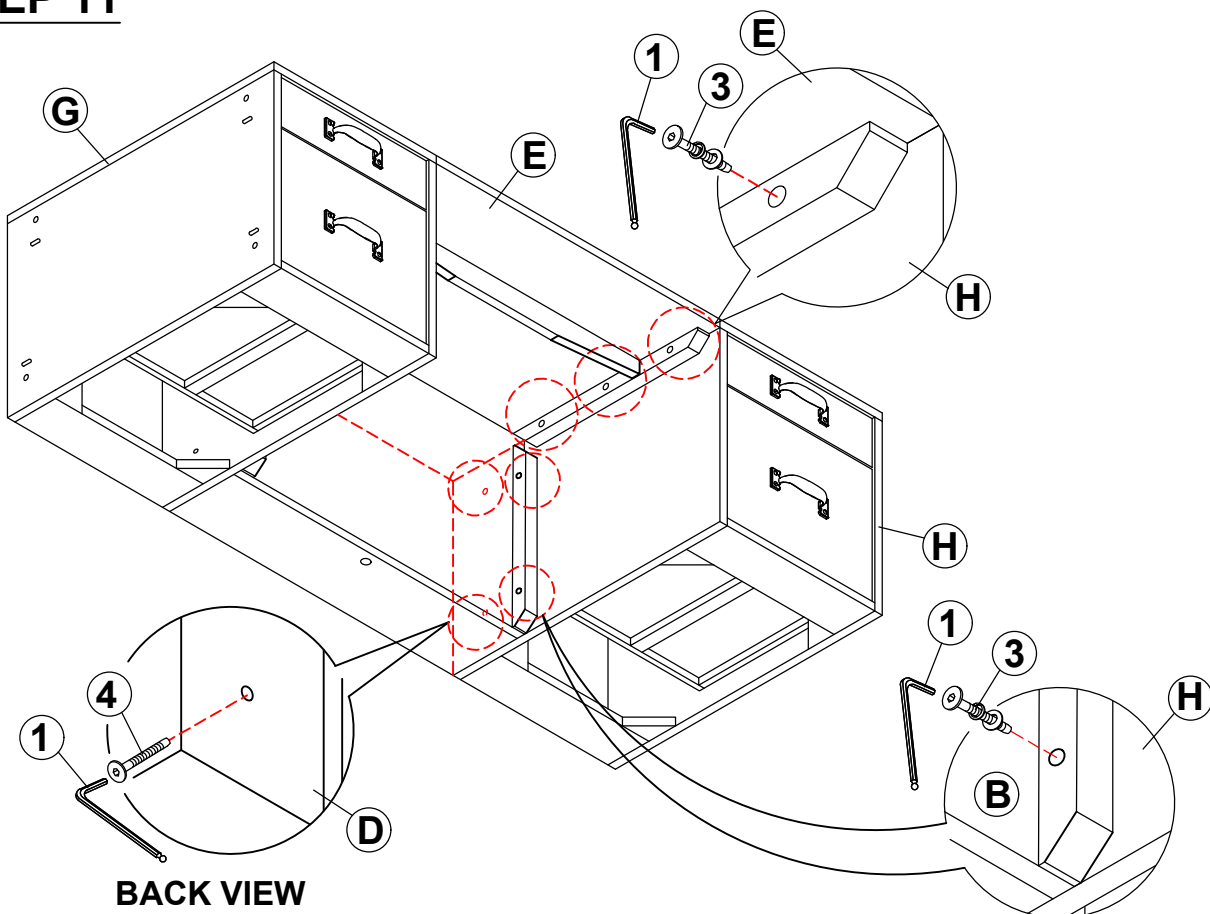

**BACK VIEW**

ITEM: **801586 (B1&B2)**



**ASSEMBLY INSTRUCTIONS**  
**STEP 12**

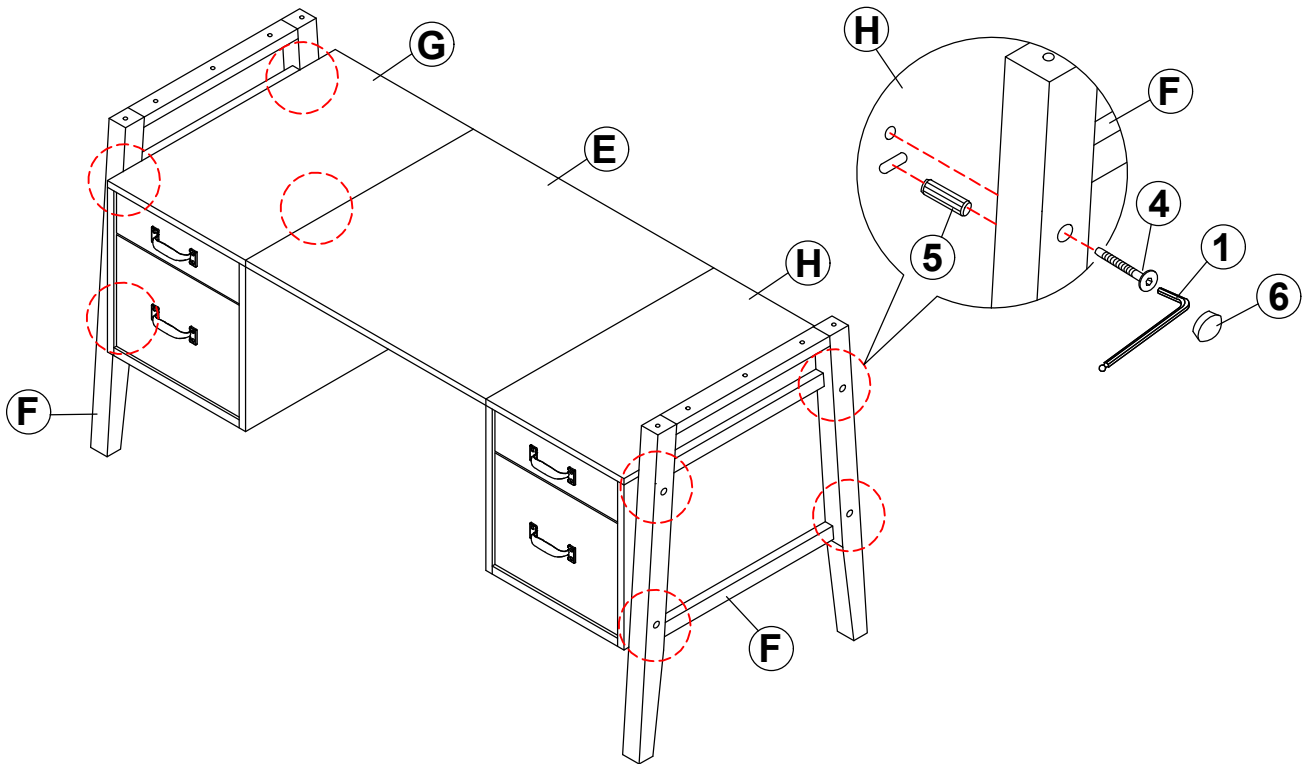

**STEP 13**

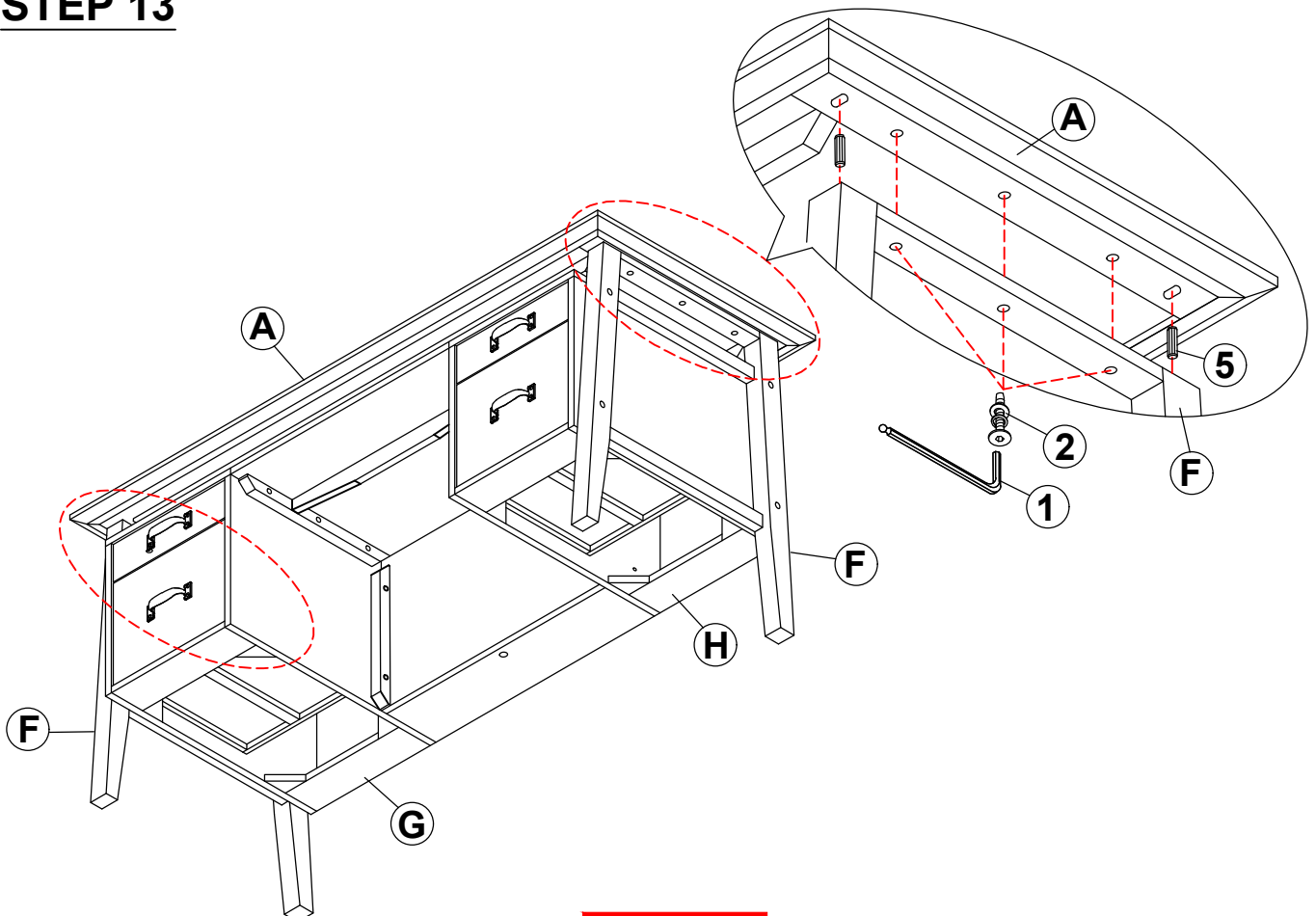

ITEM: **801586 (B1&B2)**



**ASSEMBLY INSTRUCTIONS**

**STEP 14**

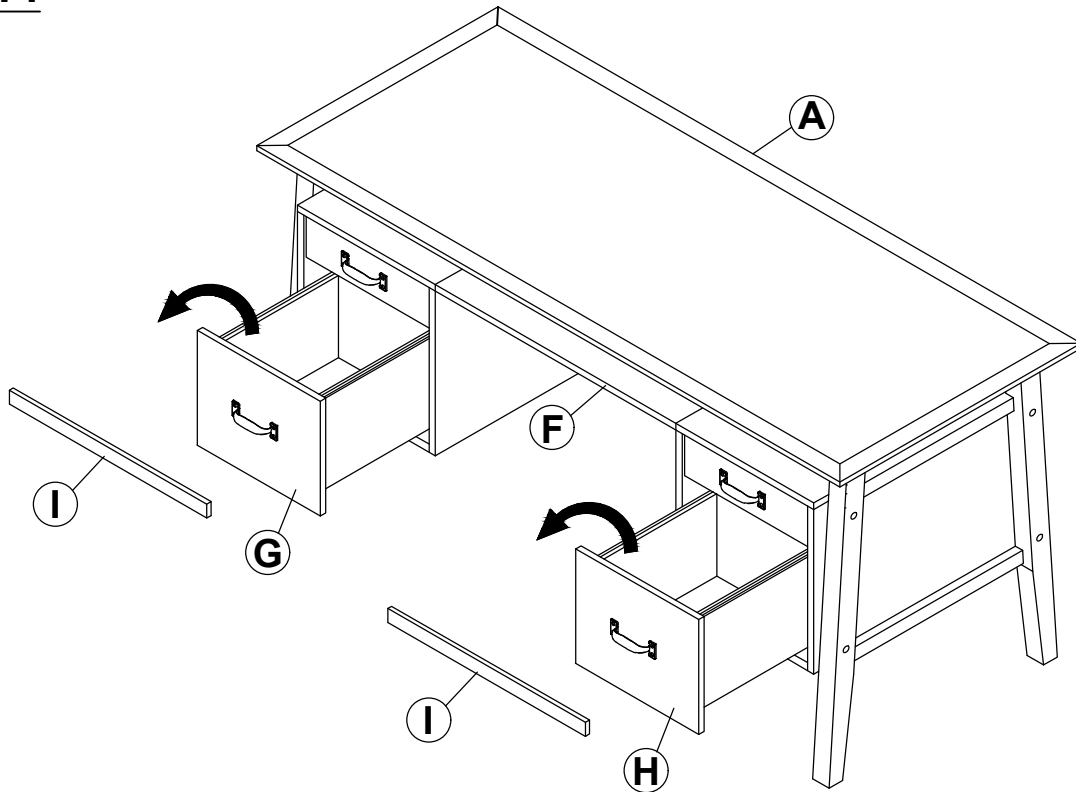

**STEP 15**

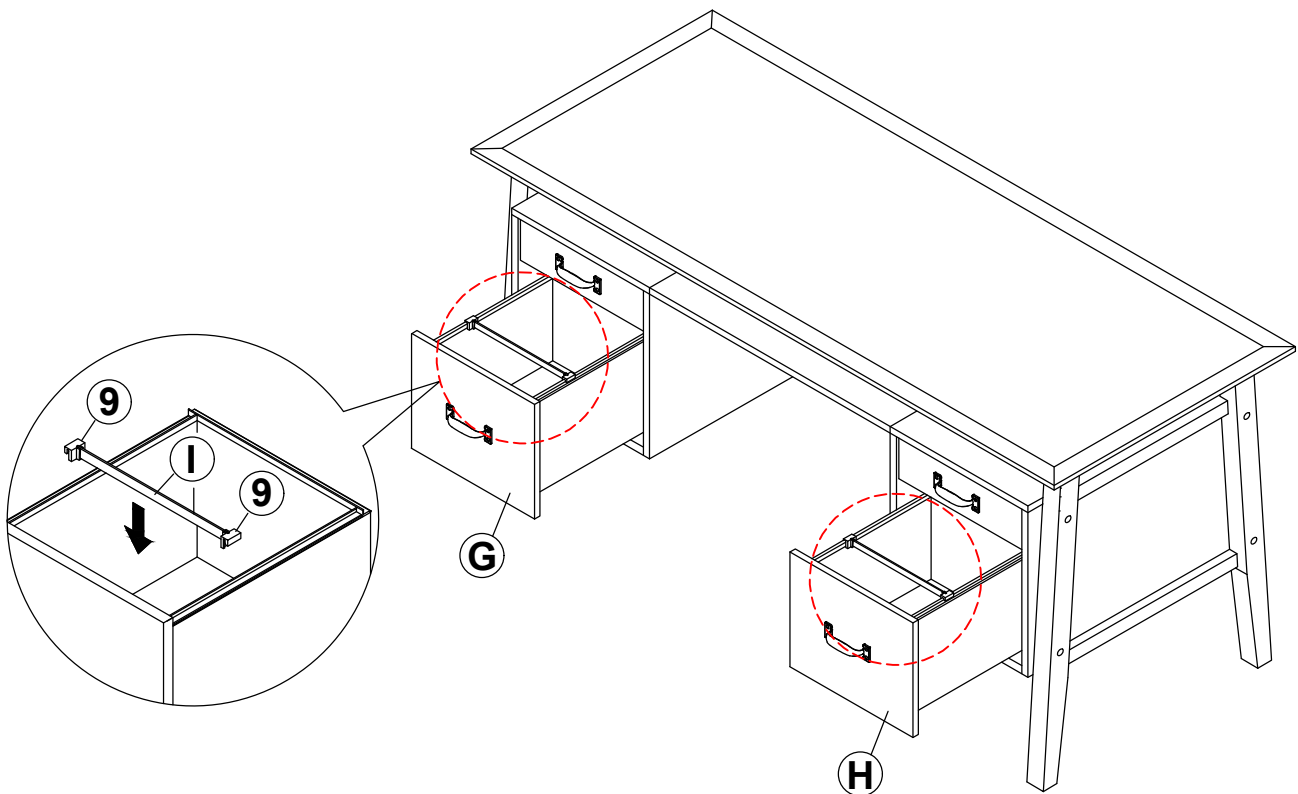

ITEM: **801586 (B1&B2)**

**ASSEMBLY INSTRUCTIONS**

**STEP 16**

**COMPLETE**

