

ASSEMBLY INSTRUCTIONS
COASTER FINE FURNITURE



www.coastercompany.com

ASSEMBLY TIPS :

1. Remove hardware from box and sort by size.
2. Please check to see that all hardware and parts are present prior to start of assembly.
3. Please follow attached instructions in the same sequence as numbered to assure fast & easy assembly.



Warning!

1. Don't attempt to repair or modify parts that are broken or defective. Please contact the store immediately.
2. This product is for home use only and not intended for commercial establishment.



ASSEMBLY TIME 20 MINUTES

PARTS IDENTIFICATION

A		HEADBOARD PANEL	1 PC	F		BED RAIL (WITH "F" LABEL)	2 PCS
B		LEFT HEADBOARD LEG (WITH "L" LABEL)	1 PC	G		BED RAIL (WITH "G" LABEL)	2 PCS
C		RIGHT HEADBOARD LEG (WITH "R" LABEL)	1 PC	H		BED RAIL SUPPORT LEG	2 PCS
D		FOOTBOARD	1 PC	I		BED SLAT	4 PCS
E		FOOTBOARD LEG	2 PCS	J		BED SLAT SUPPORT WITH LEVELER	4 PCS

HARDWARE IDENTIFICATION

1		SHORTEST BOLT	8 PCS	7		FLAT WASHER	14 PCS
2		SHORT BOLT	8 PCS	8		WOOD SCREW	8 PCS
3		MEDIUM BOLT	10 PCS	9		SMALL ALLEN WRENCH	1 PC
4		LONG BOLT	2 PCS	10		BIG ALLEN WRENCH	1 PC
5		WOOD DOWEL	2 PCS				
6		LOCK WASHER	14 PCS				

NOTE:PHILLIPS HEAD SCREW DRIVER IS REQUIRED IN THE ASSEMBLY PROCESS; HOWEVER, MANUFACTURER DOES NOT PROVIDE THIS ITEM.

STEP 1

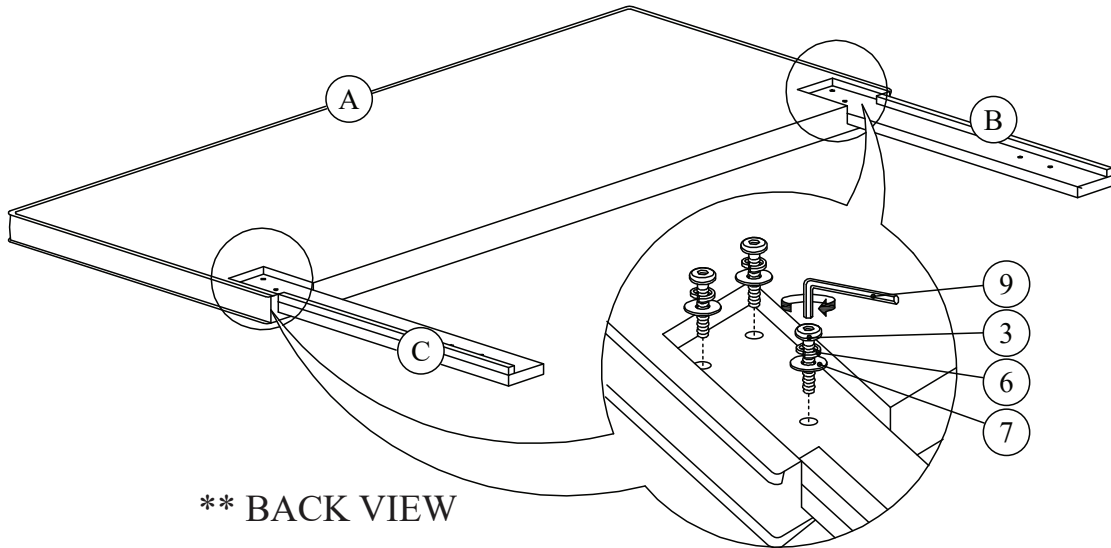

STEP 2

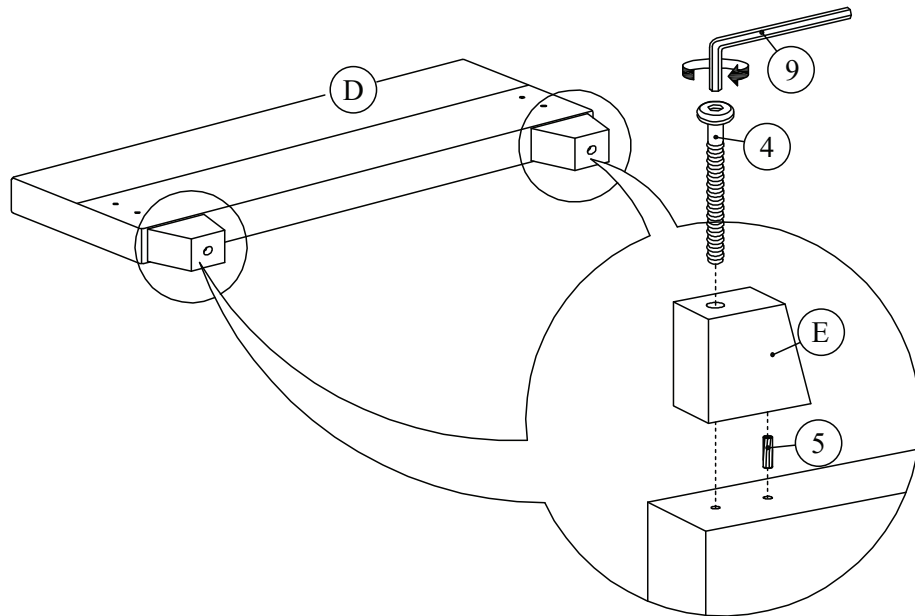

STEP 3

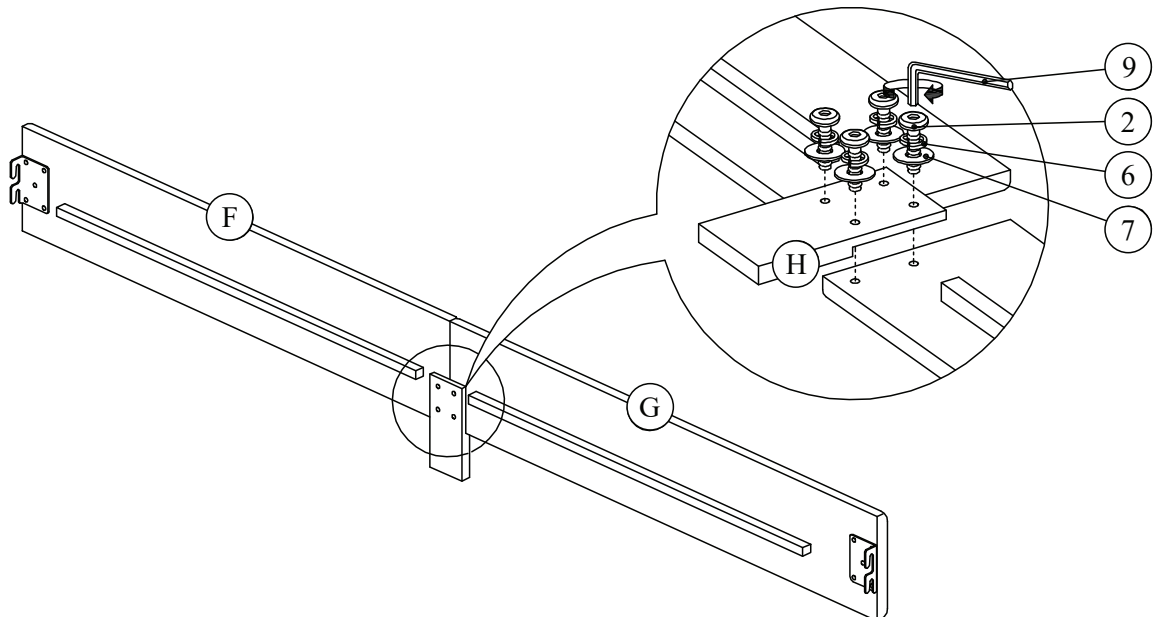

STEP 4

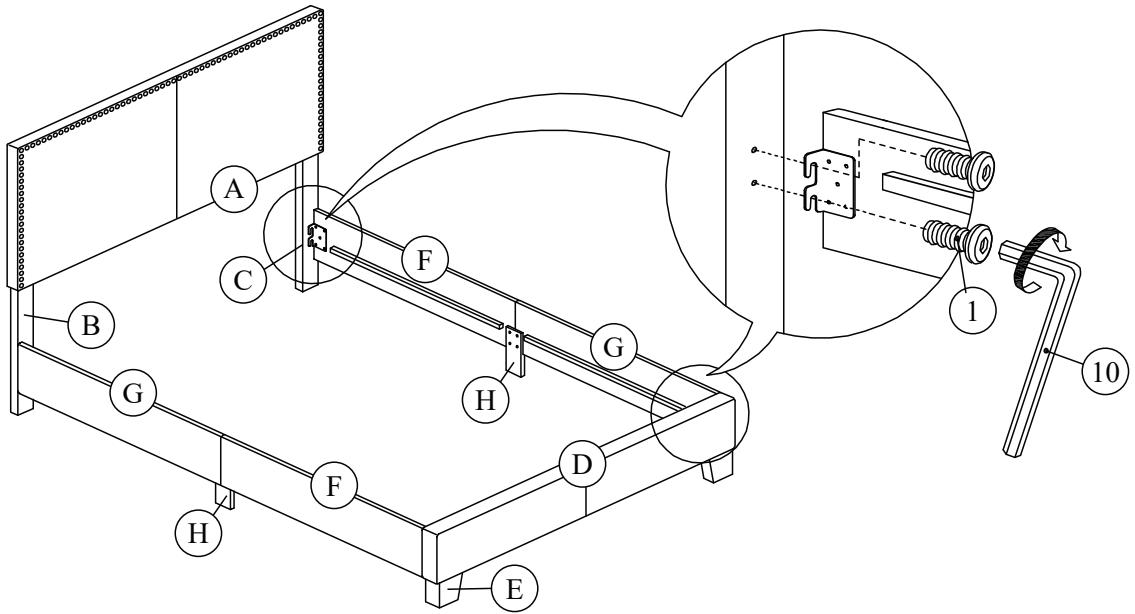

STEP 5

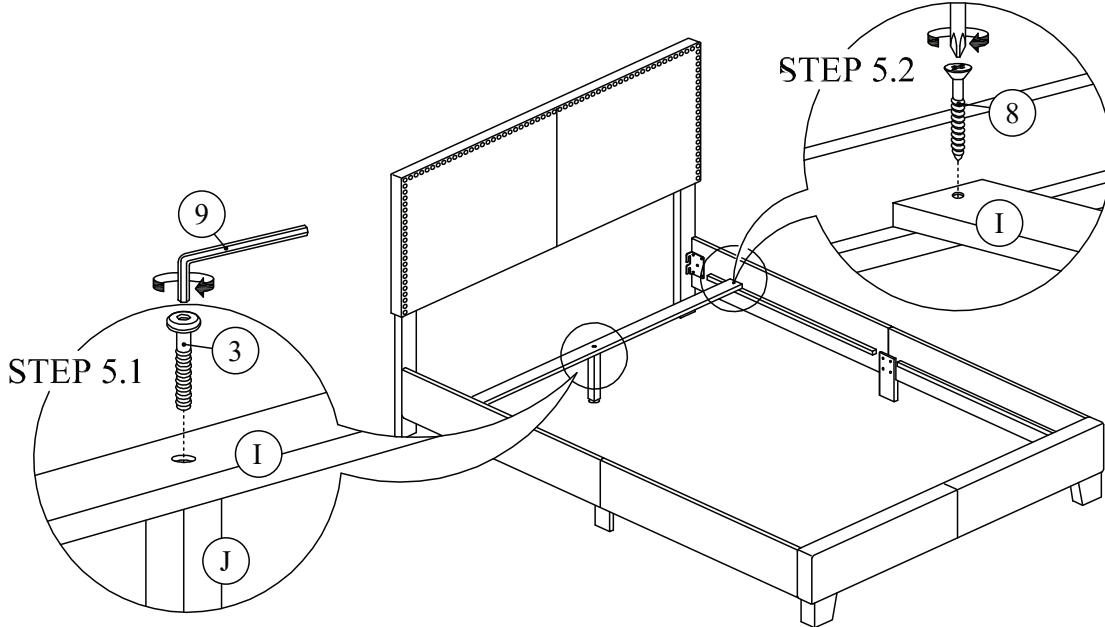

COMPLETE

