

**COASTER**  
FINE FURNITURE®

101811

BAR TABLE

ASSEMBLY INSTRUCTION  
COASTER FINE FURNITURE



[www.coasterfurniture.com](http://www.coasterfurniture.com)

2015/11/16

# Assembly Instruction

**ASSEMBLY TIPS:**

1. Remove hardware from box and sort by size.
2. Please check to see that all hardware and parts are present prior start of assembly.
3. Please follow attached instruction in the same sequence as numbered assure fast & easy assembly.

**▲Warning!**

1. Don't attempt to repair or modify parts that are broken or defective. Please contact the store immediately.
2. This product is for home use only and not intended for commercial establishment.



ASSEMBLY TIME PER UNIT: 20 MINUTES

**HARDWARE LIST:**

NO.	DESCRIPTION	FIGURE	QTY
1	ø1/4"X1/2" Bolt		8 PCS
2	ø10.5*ø7.0*1.5 Lock Washer		20 PCS
3	ø13.0*ø7.0*1.5 Flat Washer		20 PCS
4	ø1/4"X3/4" Bolt		12 PCS
5	ø35*ø8*3.0 Washer		1 PC
6	M8 Bolt		1 PC
7	4.0mm ALLEN KEY		1 PC

**PARTS LIST:**

A. Table Top

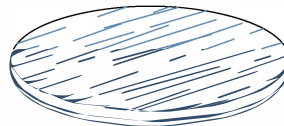

1 PC

B. Adjustable Lever

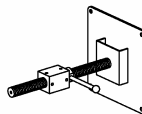

1 PC

C. Leg



4 PCS

D. Upper Stretcher

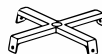

1 PC

E. Bottom Stretcher



1 PC

STEP 1:

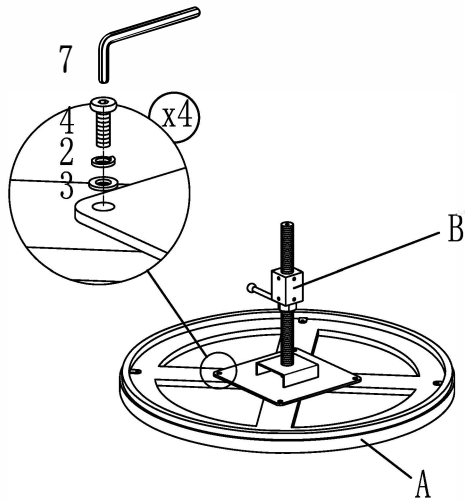

STEP 2:

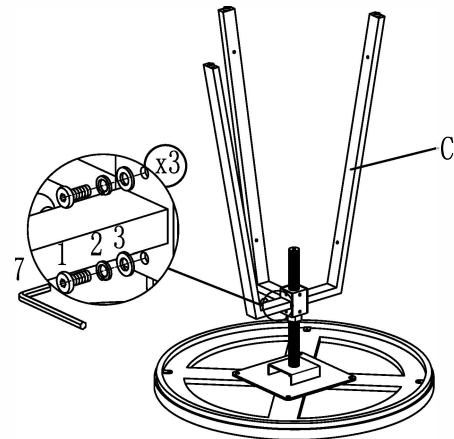

STEP 3:

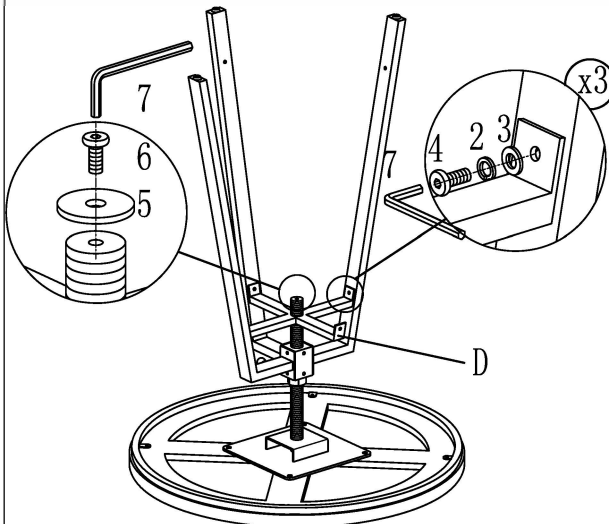

STEP 4:

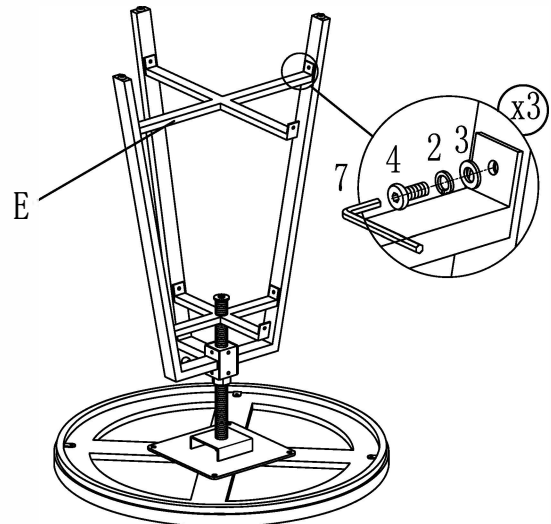

STEP 5:

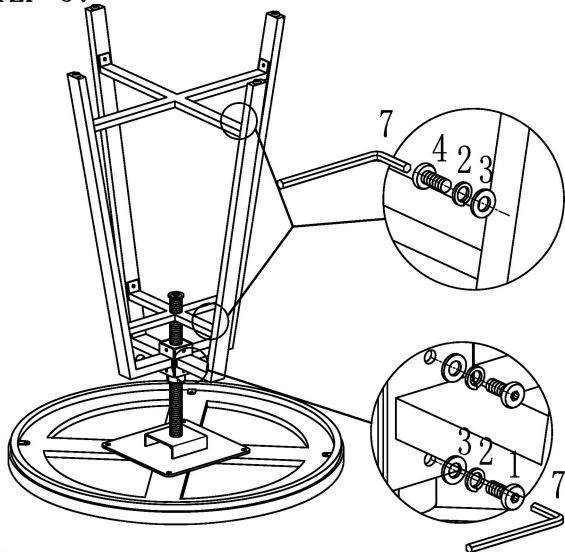

STEP 6:

