

*ASSEMBLY INSTRUCTIONS*  
*COASTER FINE FURNITURE*



*Fine Furniture for every stage of life*

**100139**  
**BAR TABLE**

REVISION 0 : 08/24/2017  
REVISION 1 : 09/06/2019

ITEM:100139



# ASSEMBLY INSTRUCTIONS

## ASSEMBLY TIPS:

1. Remove hardware from box and sort by size.
2. Please check to see that all hardware and parts are present prior to start of assembly.
3. Please follow attached instructions in the same sequence as numbered to assure fast & easy assembly.



### WARNING!

1. Don't attempt to repair or modify parts that are broken or defective. Please contact the store immediately.
2. This product is for home use only and not intended for commercial establishments.

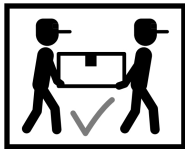

ASSEMBLY TIME 70 MINUTES

## PARTS IDENTIFICATION

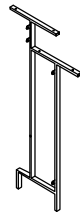
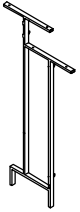
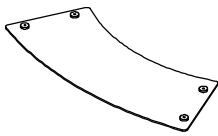
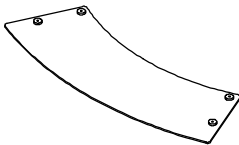
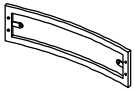
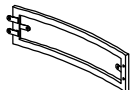



A	RIGHT SIDE		1PC
B	LEFT SIDE		1PC
C	TOP GLASS SHELF		1PC
D	BAR TABLE GLASS		1PC
E	FRONT SMALL RIGHT FRAME		1PC
F	FRONT SMALL LEFT FRAME		1PC

ITEM:100139

# ASSEMBLY INSTRUCTIONS

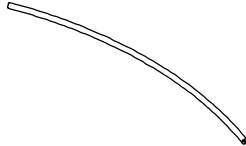
## PARTS IDENTIFICATION

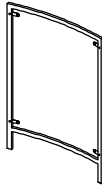
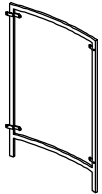

G	FOOT REST BAR		1PC
H	BOTTOM SHELF FRAME		1PC
I	BOTTOM GLASS SHELF		1PC
J	FRONT LARGE RIGHT PAENL		1PC
K	FRONT LARGE LEFT PAENL		1PC
L	GLASS HOLDER		1PC
M	BOTTLE RACK		2PCS

ITEM:100139

# ASSEMBLY INSTRUCTIONS

## PARTS IDENTIFICATION



N BOTTLE RACK TOP BAR 2PCS

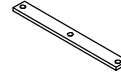

O BOTTLE RACK BOTTOM BAR 2PCS

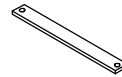

P FOOT REST SIDE LEG 2PCS

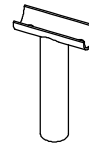

Q FOOT REST MIDDLE LEG 1PC

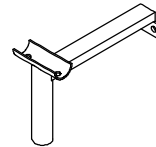

R FOOT REST SIDE PLATE 2PCS

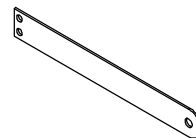

S SMALL ACRYLIC 2PCS



T LARGE ACRYLIC 2PCS

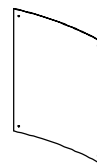

















ITEM:100139

# ASSEMBLY INSTRUCTIONS



## HARDWARE IDENTIFICATION

1	LARGE ALLEN BOLT (1/4" x 1-1/2" BLK)		2PCS	10	BOTTLE RACK BOLT (3/16" x 12mm SR)		12PCS
2	MEDIUM ALLEN BOLT (1/4" x 3/4" SR)		18PCS	11	ALLEN KEY (4mm)		1PC
3	SMALL ALLEN BOLT (1/4" x 1/2" BLK)		20PCS	12	HEXAGONAL KEY (3/16")		1PC
4	REC CAP (13 x 26mm BLK)		24PCS	13	BOLT (1/4" x 25mm SR)		2PCS
5	ROUND CAP (Ø25mm BLK)		3PCS	14	PLASTIC BOLT (Ø35mm)		12PCS
6	FLOOR LEVELER (Ø50mm BLK)		3PCS	15	WASHER (1/4" x 19mm)		12PCS
7	BOLT (1/4" x 7/8" SR)		2PCS	16	HAT NUT (1/4")		12PCS
8	SUCTION CUP (Ø12mm)		6PCS	17	LARGE HEXAGONAL KEY (10mm)		1PC
9	NUT (3/16" SR)		8PCS				

# ITEM: 100139 ASSEMBLY INSTRUCTIONS



**STEP 1** Do not tighten until each step is completed or instructed.

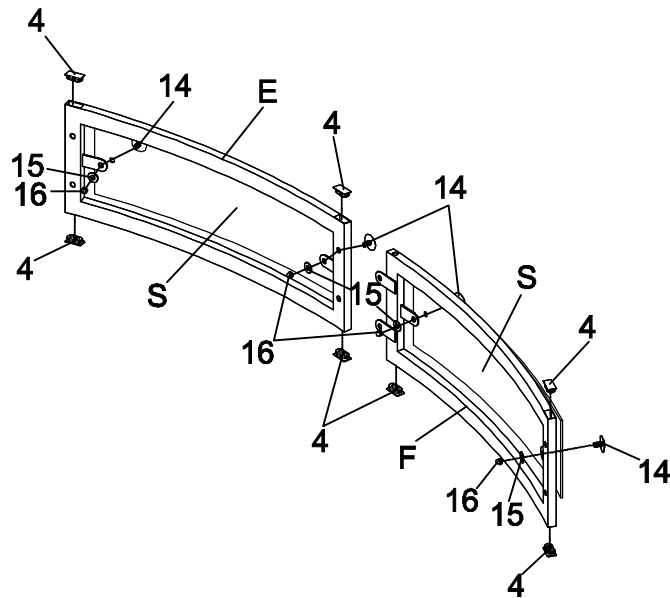

## STEP 2

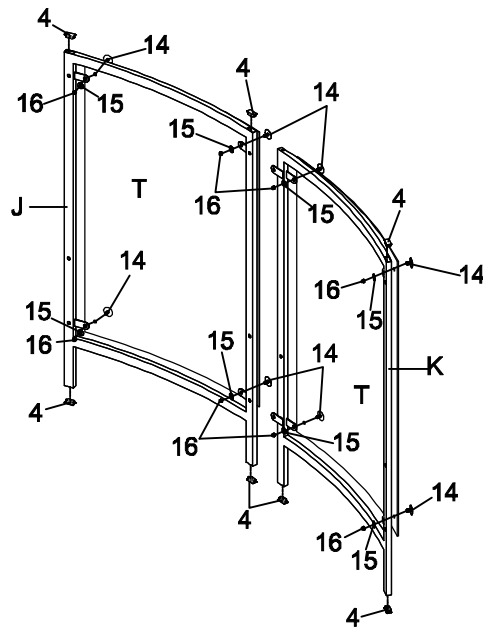

ITEM: 100139  
ASSEMBLY INSTRUCTIONS  
STEP 3

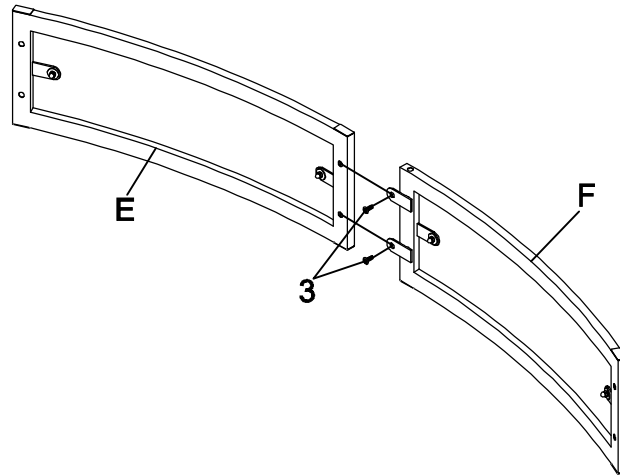

STEP 4

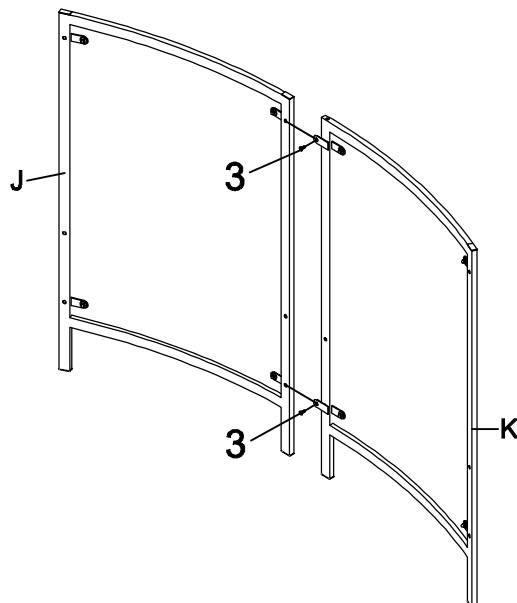

ITEM: 100139  
ASSEMBLY INSTRUCTIONS



STEP 5

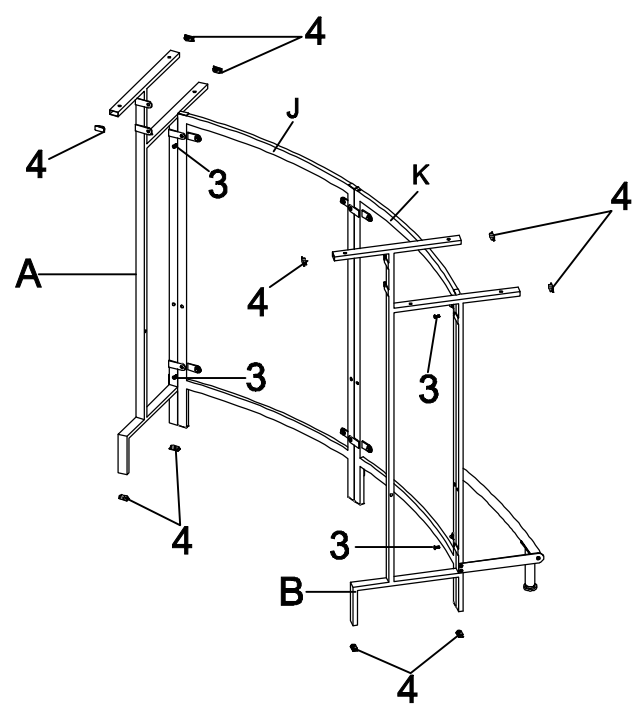

STEP 6

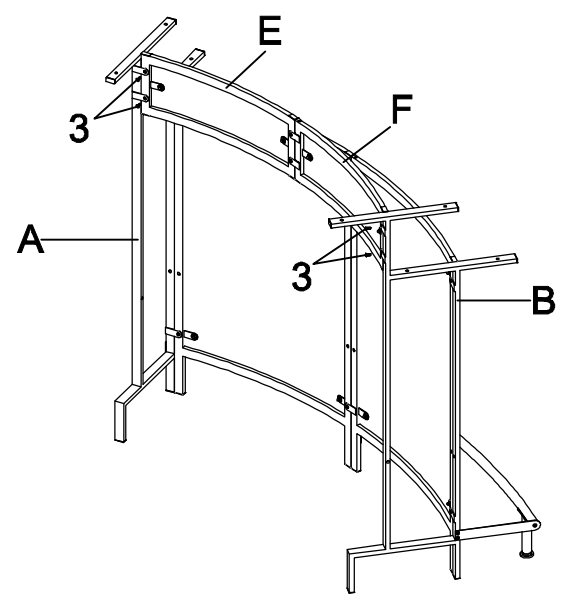



ITEM: 100139  
ASSEMBLY INSTRUCTIONS  
STEP 7

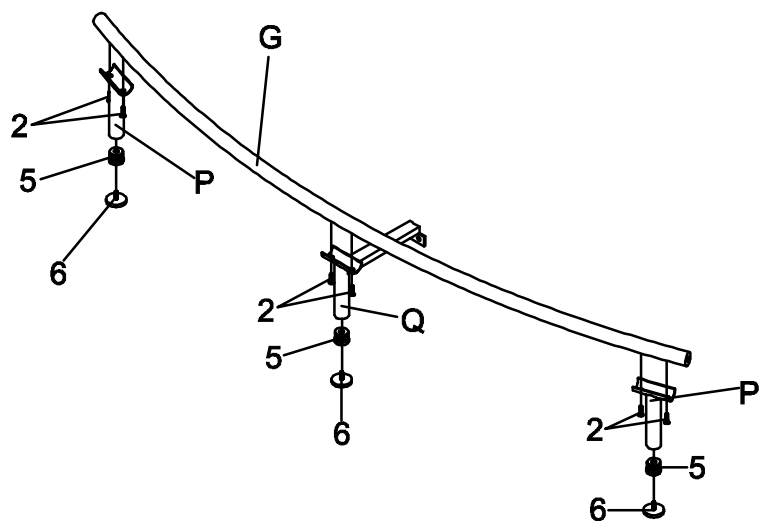

STEP 8

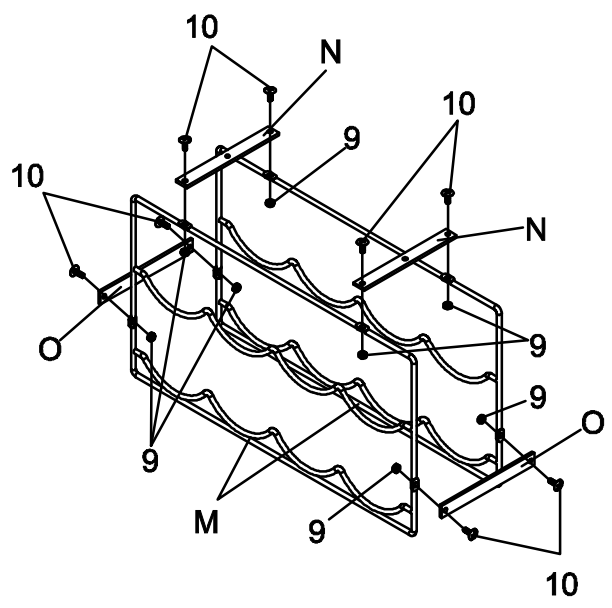

ITEM: 100139  
ASSEMBLY INSTRUCTIONS  
STEP 9

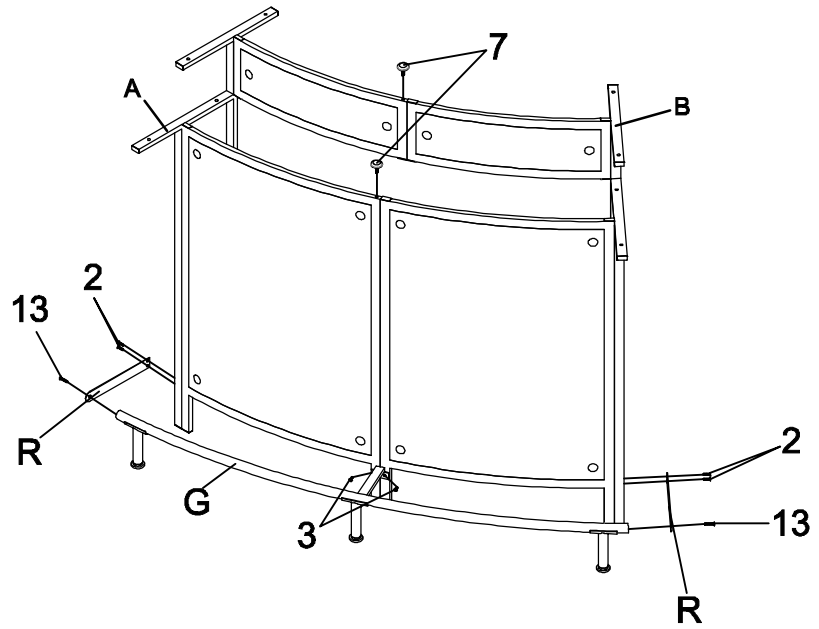

STEP 10

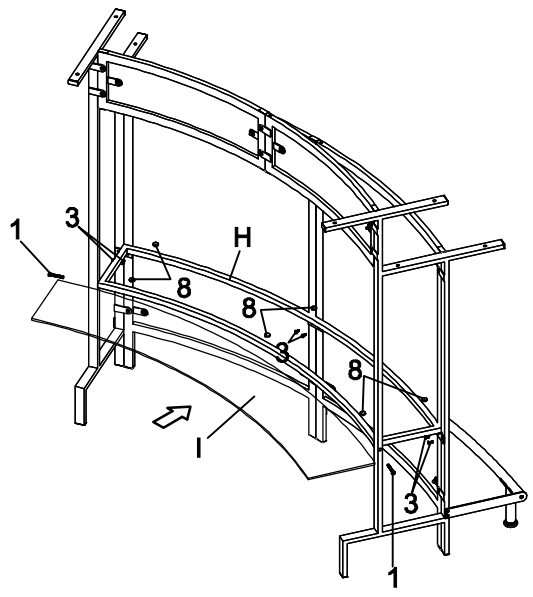

ITEM: 100139  
ASSEMBLY INSTRUCTIONS  
STEP 11

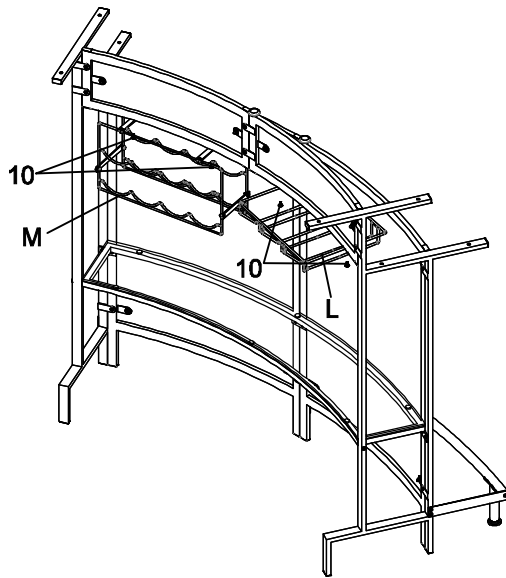

STEP 12

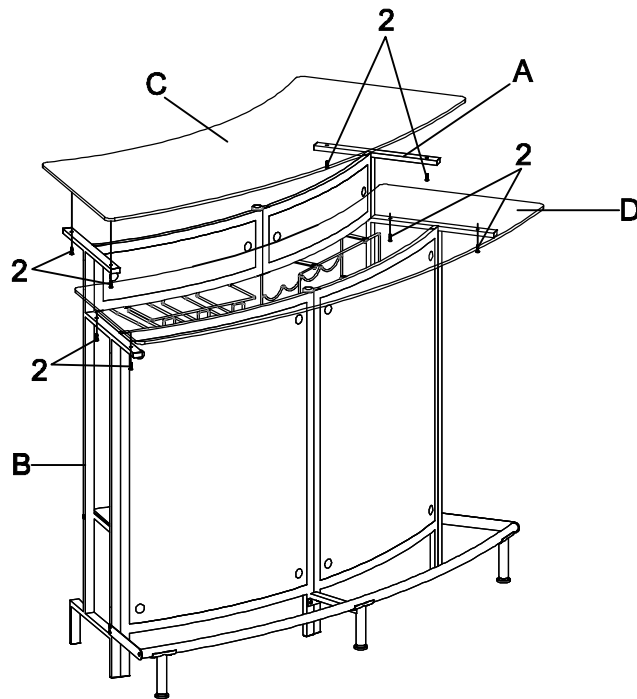

ITEM: 100139  
ASSEMBLY INSTRUCTIONS



STEP 13  
COMPLETE

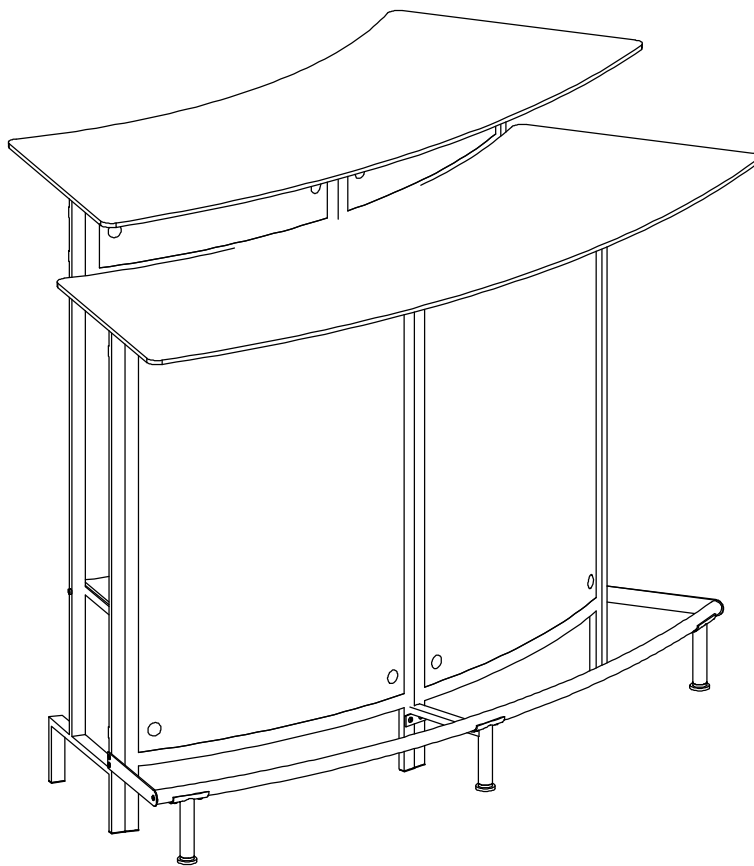

How to clean Acrylic product:  
Using a dry soft microfiber cloth, lightly brush off any dust.  
For additional care, dampen the cloth with warm water.  
For deepest cleaning, use an Acrylic cleaner.

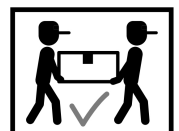

# ITEM:100139 ASSEMBLY INSTRUCTIONS

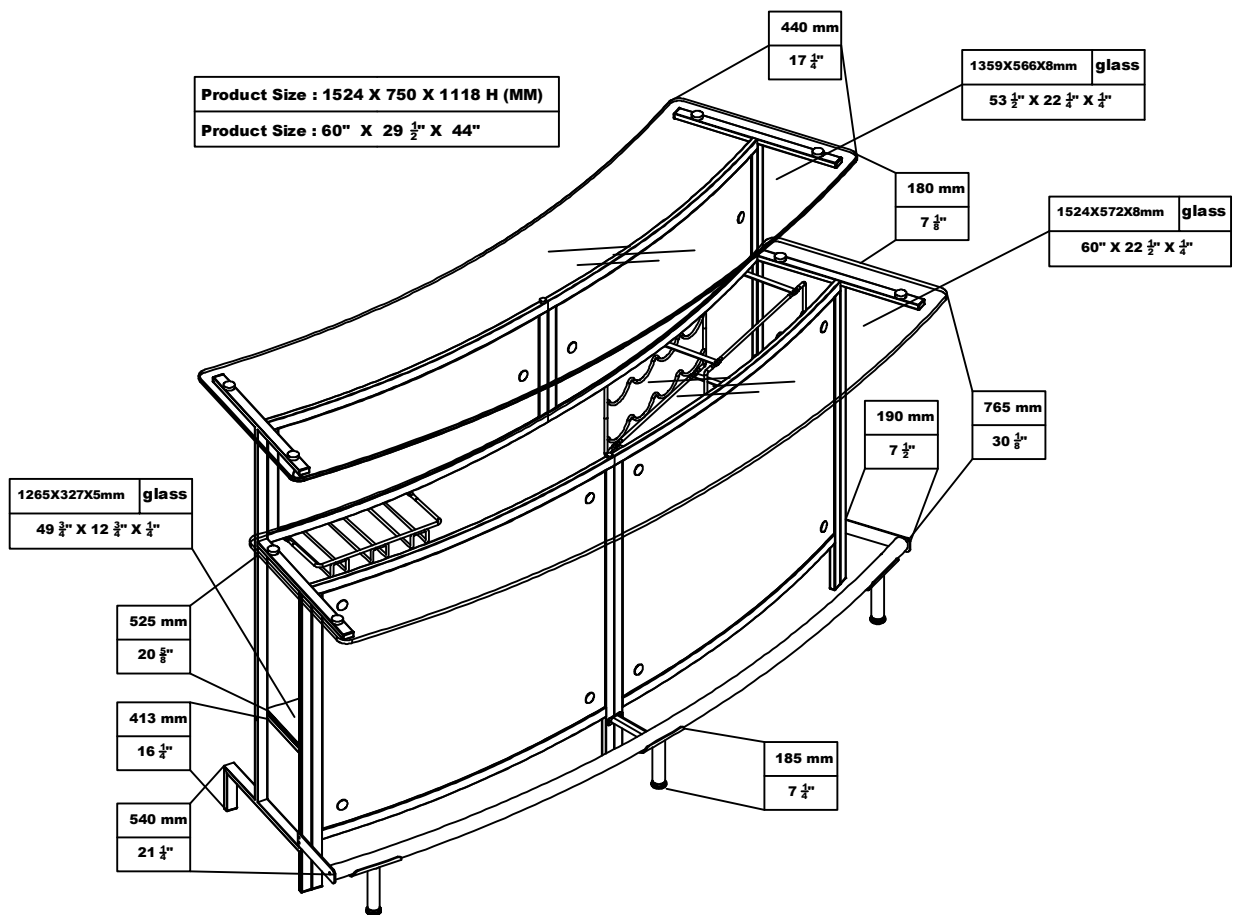

Note : Dimension tolerance  $\pm 5\%$