

ASSEMBLY INSTRUCTIONS
COASTER FINE FURNITURE

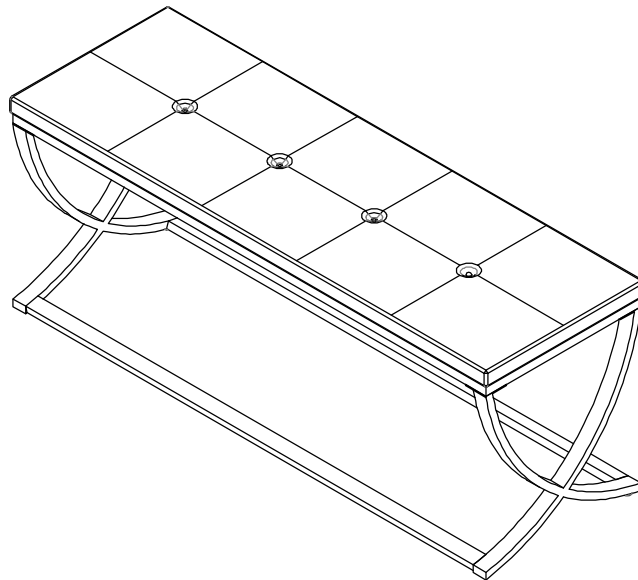

Fine Furniture for every stage of life

501156
BENCH

REVISION 0 : 09/05/2017
REVISION 1 : 10/17/2019

ITEM:501156



ASSEMBLY INSTRUCTIONS

ASSEMBLY TIPS:

1. Remove hardware from box and sort by size.
2. Please check to see that all hardware and parts are present prior to start of assembly.
3. Please follow attached instructions in the same sequence as numbered to assure fast & easy assembly.





WARNING!



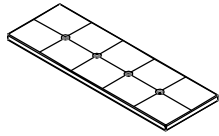
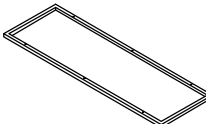
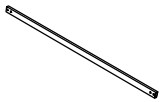

1. Don't attempt to repair or modify parts that are broken or defective. Please contact the store immediately.
2. This product is for home use only and not intended for commercial establishments.

ASSEMBLY TIME 35 MINUTES

PARTS IDENTIFICATION

A	CUSHION		1PC
B	CUSHION FRAME		1PC
C	CROSSBAR		2PCS
D	SIDE		2PCS

HARDWARE IDENTIFICATION

1	SCREW (8# x 35mm)		6PCS	3	LEVELER (1/4" x 12mm BLK)		4PCS
2	ALLEN BOLT (1/4" x 12mm SR)		16PCS	4	ALLEN WRENCH (4mm)		1PC

ITEM: 501156 ASSEMBLY INSTRUCTIONS



STEP 1 Do not tighten until each step is completed or instructed.

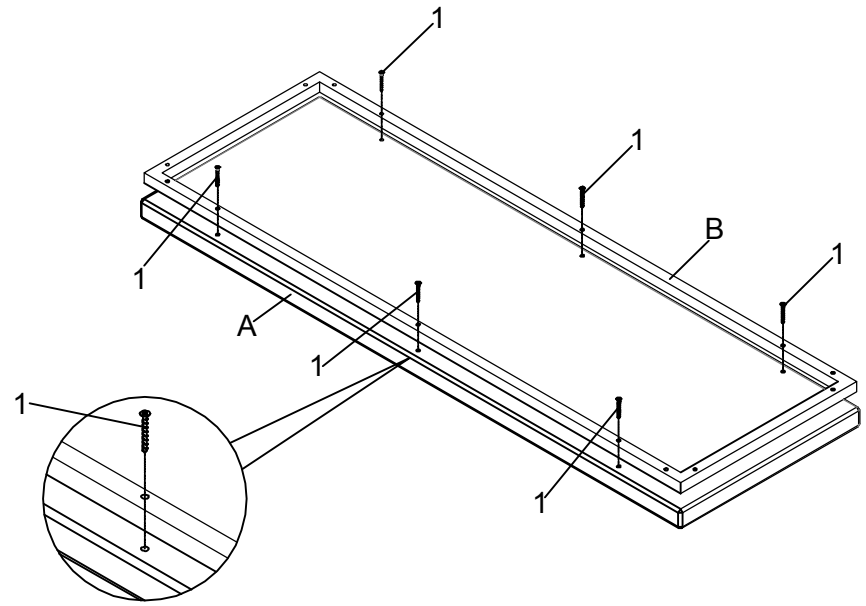

STEP 2

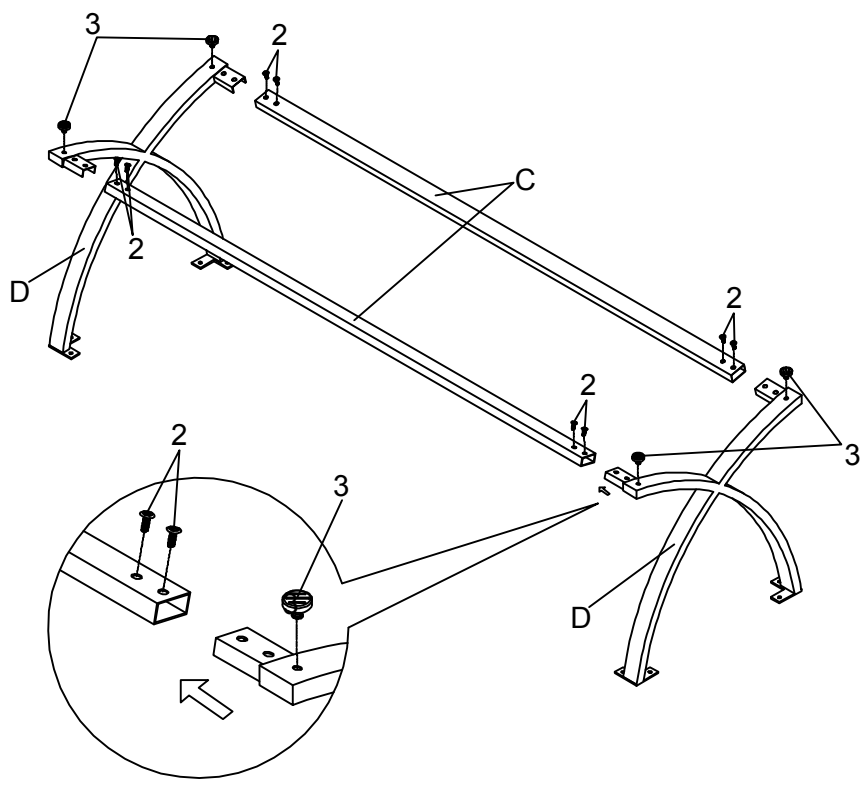

ITEM: 501156
ASSEMBLY INSTRUCTIONS



STEP 3

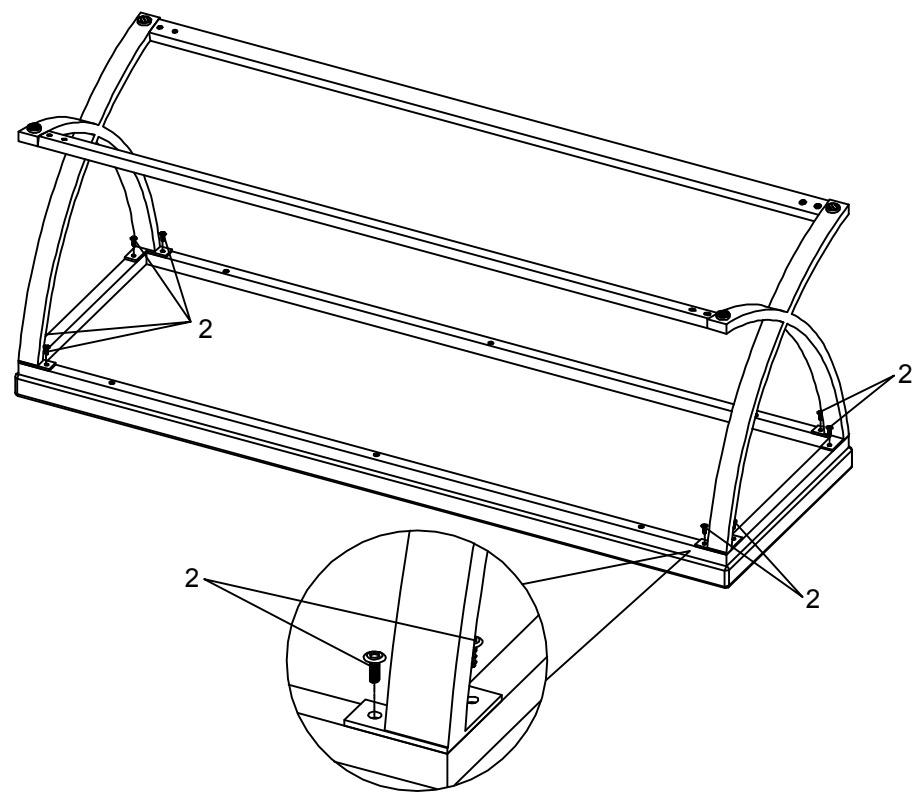

STEP 4
COMPLETE

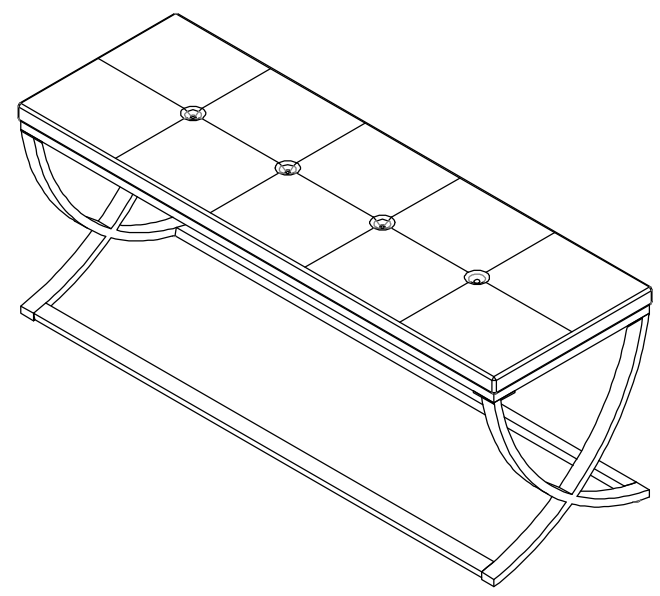

ITEM: 501156 ASSEMBLY INSTRUCTIONS



Product Size : 1219 X 406 X 470 H (MM)
Product Size : 48" X 16" X 18 1/2"

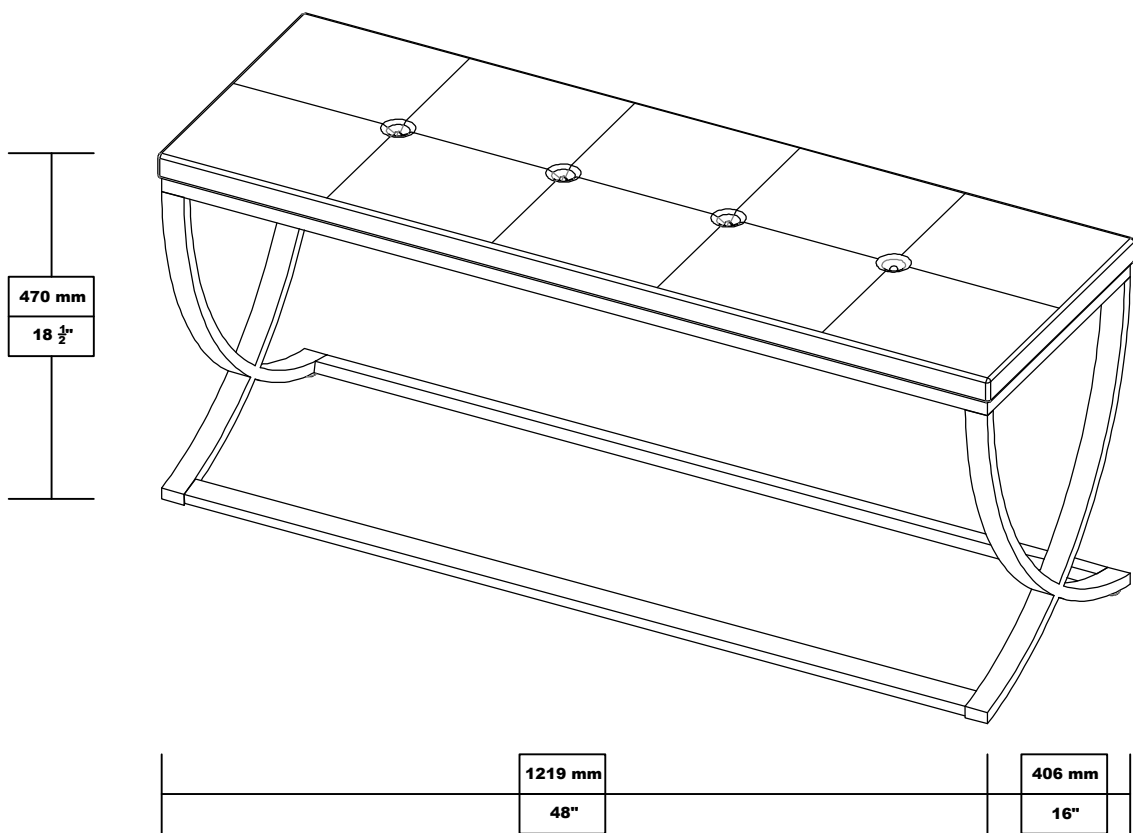

Note : Dimension tolerance $\pm 5\%$