

*ASSEMBLY INSTRUCTIONS*  
*COASTER FINE FURNITURE*



*Fine Furniture for every stage of life*

**702588**  
**COFFEE TABLE**

REVISION 0 : 04/27/2018  
REVISION 1 : 10/08/2019

ITEM: 702588



# ASSEMBLY INSTRUCTIONS

## ASSEMBLY TIPS:

1. Remove hardware from box and sort by size.
2. Please check to see that all hardware and parts are present prior to start of assembly.
3. Please follow attached instructions in the same sequence as numbered to assure fast & easy assembly.



## WARNING!

1. Don't attempt to repair or modify parts that are broken or defective. Please contact the store immediately.
2. This product is for home use only and not intended for commercial establishments.



ASSEMBLY TIME 35 MINUTES

## PARTS IDENTIFICATION

A TOP FRAME



1PC

B LEG



4PCS

C TOP GLASS

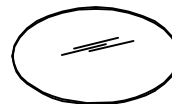

1PC

## HARDWARE IDENTIFICATION

1 CAP  
(20 x 40 mm)



4PCS

2 ALLEN BOLT  
(1/4" x 2")



4PCS

3 SMALL ALLEN BOLT  
(1/4" x 1/2")



4PCS

4 FLOOR LEVELER  
(1/4" x 5/8")



4PCS

5 SUCTION CUP  
(8mm)



4PCS

6 ALLEN WRENCH  
(4mm)



1PC

ITEM: 702588  
**ASSEMBLY INSTRUCTIONS**



**STEP 1** Do not tighten until each step is completed or instructed.

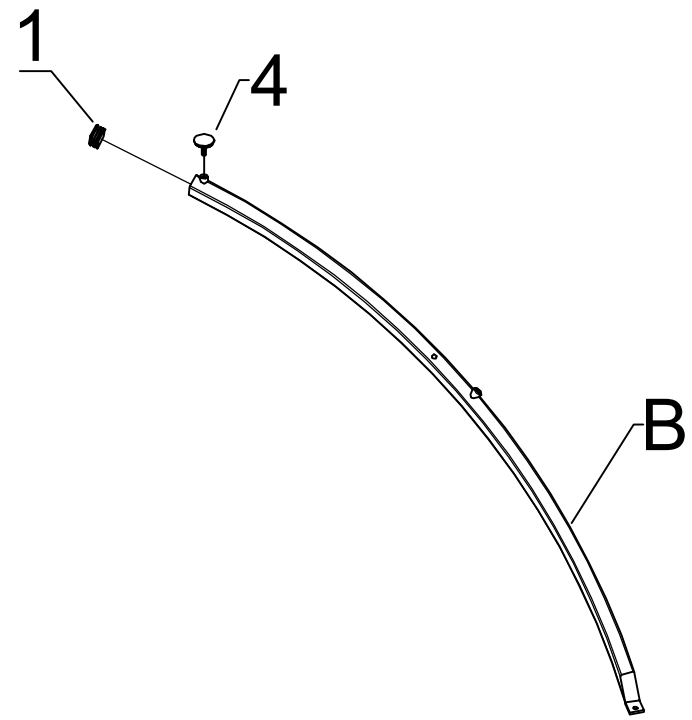

**STEP 2**

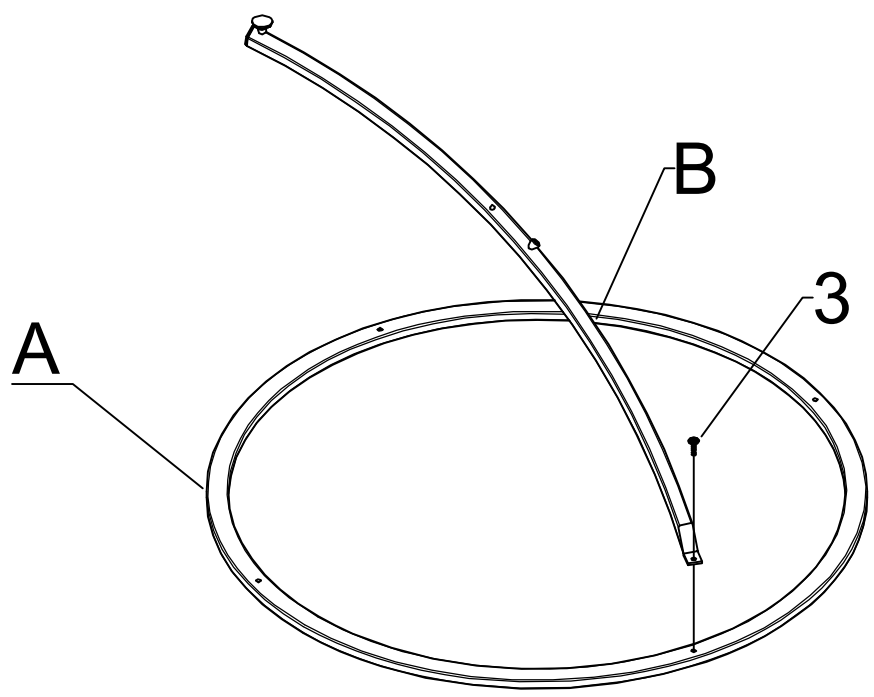

ITEM: 702588  
ASSEMBLY INSTRUCTIONS  
STEP 3

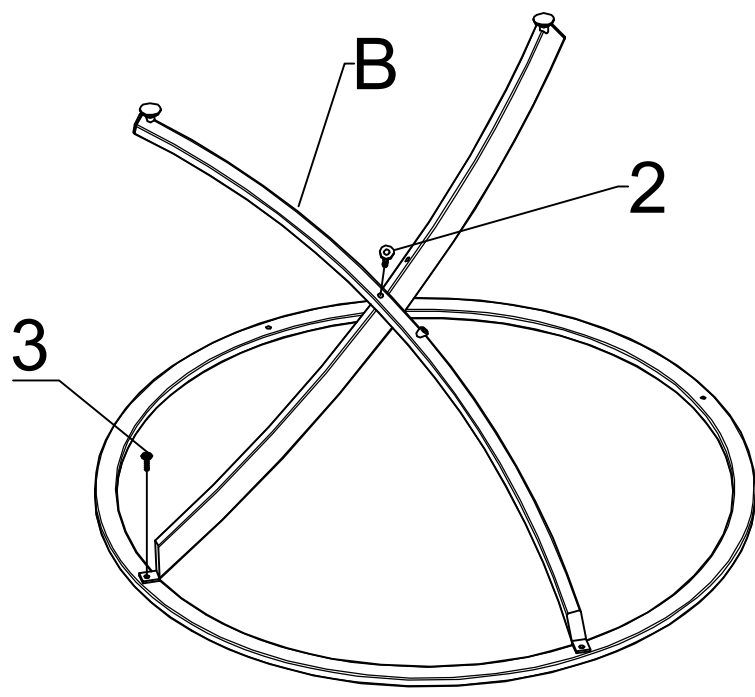

STEP 4

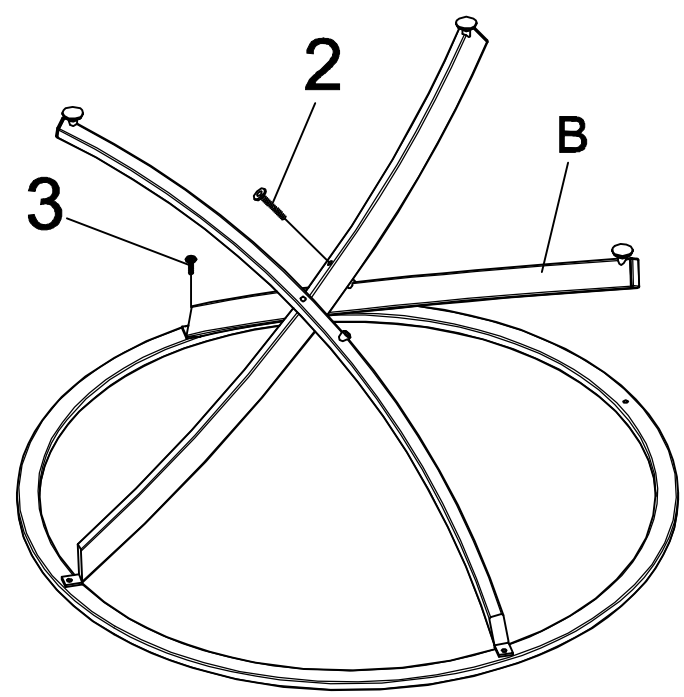

ITEM: 702588  
ASSEMBLY INSTRUCTIONS  
STEP 5

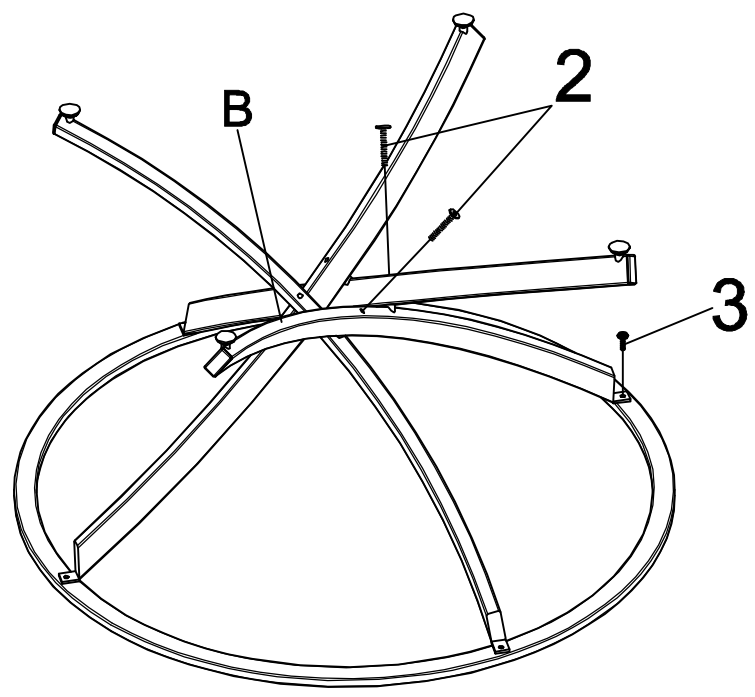

STEP 6

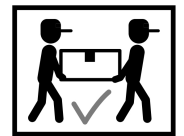
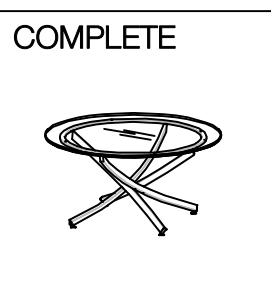
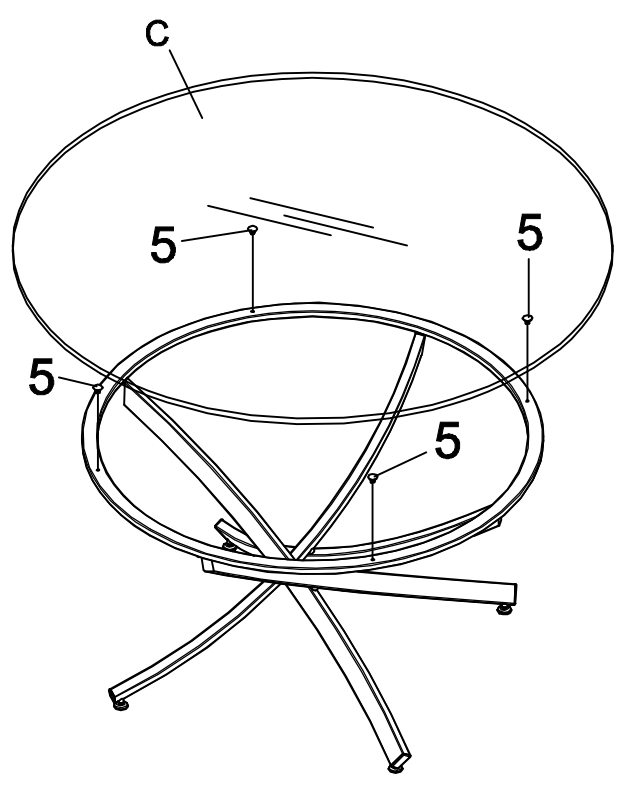

# ITEM: 702588 ASSEMBLY INSTRUCTIONS

<b>Product Size : 900 X 900 X 508 H (MM)</b>
<b>Product Size : 35 ½" X 35 ½" X 20"</b>

<b>900X900X8 mm</b>	<b>solid</b>
<b>35 ½" X 35 ½" X 8 mm</b>	

<b>50mm</b>
<b>2"</b>

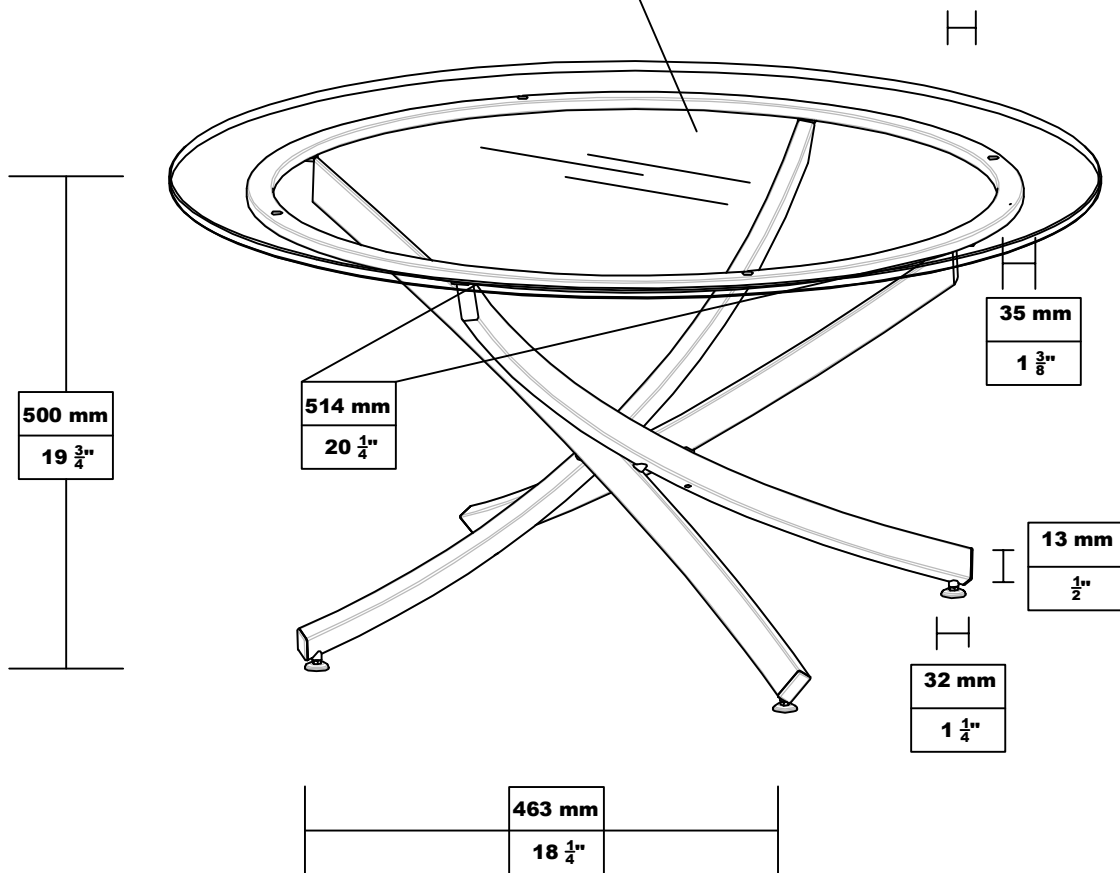

Note : Dimension tolerance ±5%