

ASSEMBLY INSTRUCTIONS
COASTER FINE FURNITURE

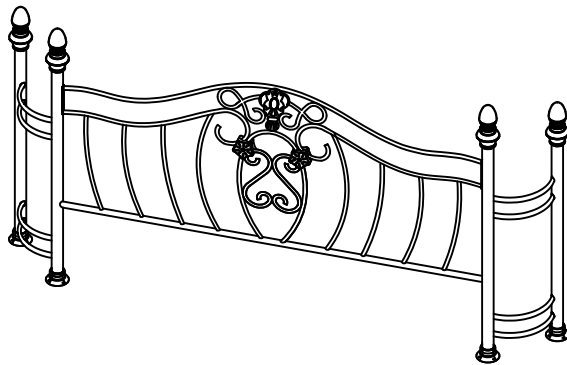
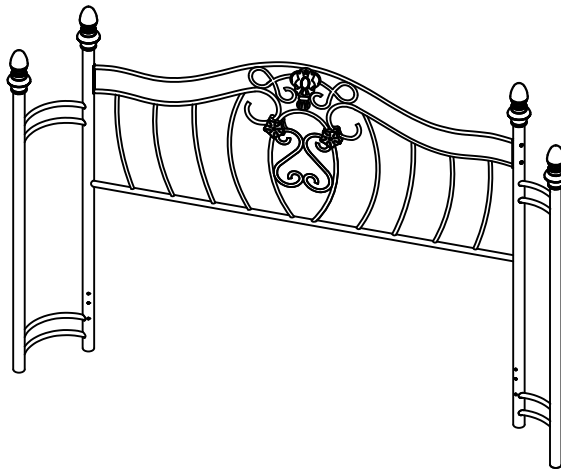

Fine Furniture for every stage of life

300171QB1/B2
Metal Queen Size Bed

ITEM: **901073**



ASSEMBLY INSTRUCTIONS

ASSEMBLY TIPS:

1. Remove hardware from box and sort by size.
2. Please check to see that all hardware and parts are present prior to start of assembly.
3. Please follow attached instructions in the same sequence as numbered to assure fast & easy assembly.



WARNING!

1. Don't attempt to repair or modify parts that are broken or defective. Please contact the store immediately.
2. This product is for home use only and not intended for commercial establishments.

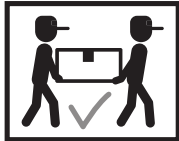

ASSEMBLY TIME

30 MINUTES

PARTS IDENTIFICATION

A FRAME

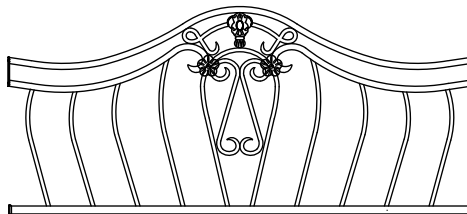

2PCS

B POST FOR HEAD BOARD (LEFT)



1PC

E POST FOR FOOT BOARD (RIGHT)

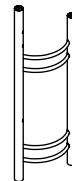

1PC

C POST FOR HEAD BOARD (RIGHT)



1PC

F BALL



8PCS

D POST FOR FOOT BOARD (LEFT)



1PC

G FOOT PAD











4PCS

NOTE:

Phillips head screw driver is required in the assembly process; however, manufacturer does not provide this item.

HARDWARE IDENTIFICATION

1	LONG BOLT (Φ1/4"x2-1/2")		16PCS		5 FLAT WASHER (Φ23xΦ8.5x3.0)		8PCS
2	SMALL BOLT (Φ1/4"x3/4")		8PCS		6 LOCK WASHER (Φ1/4")		4PCS
3	SPRING WASHER (Φ10.5xΦ6.5x1.5)		8PCS		7 ALLEN KEY (4mm)		1PC
4	FLAT WASHER (Φ16.0xΦ6.5x1.5)		12PCS		8 WRENCH (11.0mm)		1PC

NOTE:

Phillips head screw driver is required in the assembly process; however, manufacturer does not provide this item.

ITEM: **901073**

ASSEMBLY INSTRUCTIONS

STEP 1

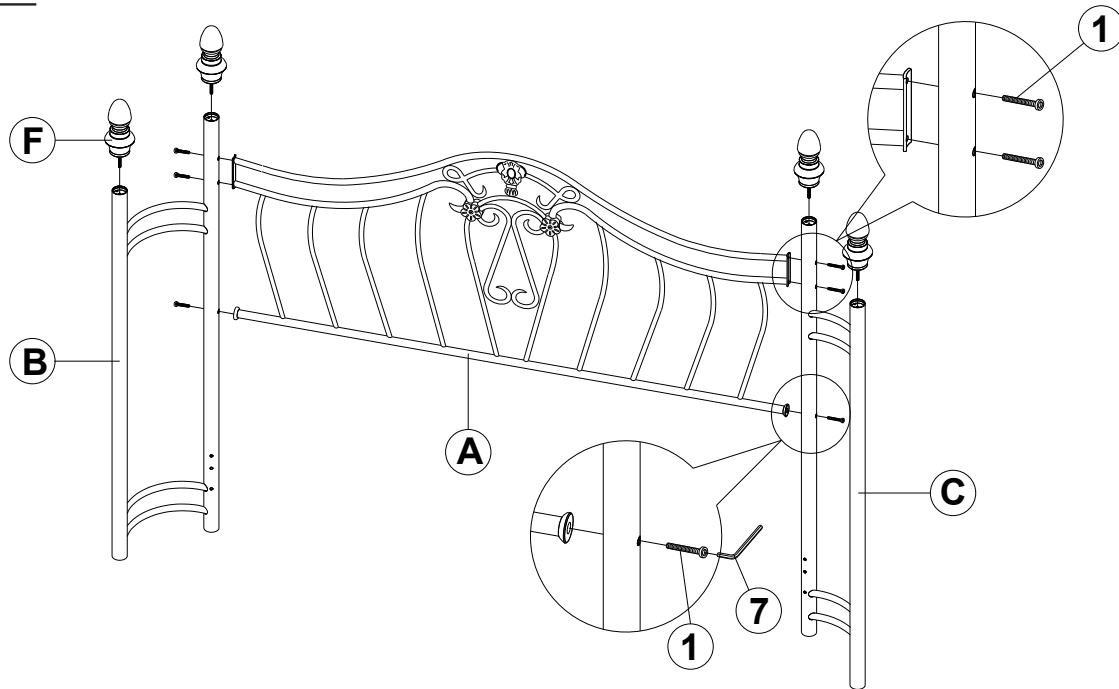

STEP 2

