

ASSEMBLY INSTRUCTIONS
COASTER FINE FURNITURE



Fine Furniture for every stage of life

110101
DINING TABLE

ITEM:110101



ASSEMBLY INSTRUCTIONS

ASSEMBLY TIPS:

1. Remove hardware from box and sort by size.
2. Please check to see that all hardware and parts are present prior to start of assembly.
3. Please follow attached instructions in the same sequence as numbered to assure fast & easy assembly.



WARNING!

1. Don't attempt to repair or modify parts that are broken or defective. Please contact the store immediately.
2. This product is for home use only and not intended for commercial establishments.



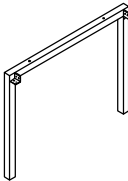
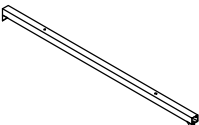
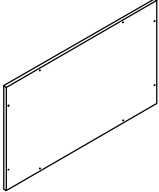
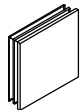

ASSEMBLY TIME 35 MINUTES

PARTS IDENTIFICATION

A	SIDE FRAME		2PCS
B	CROSSBAR		2PCS
C	TOP		1PC
D	CAP		4PCS

HARDWARE IDENTIFICATION

1	LONG BOLT (1/4" x 57mm)		8PCS	3	ALLEN WRENCH (4mm)		1PC
2	SHORT BOLT (1/4" x 13mm)		20PCS				

ITEM: 110101 ASSEMBLY INSTRUCTIONS



STEP 1 Do not tighten until each step is completed or instructed.

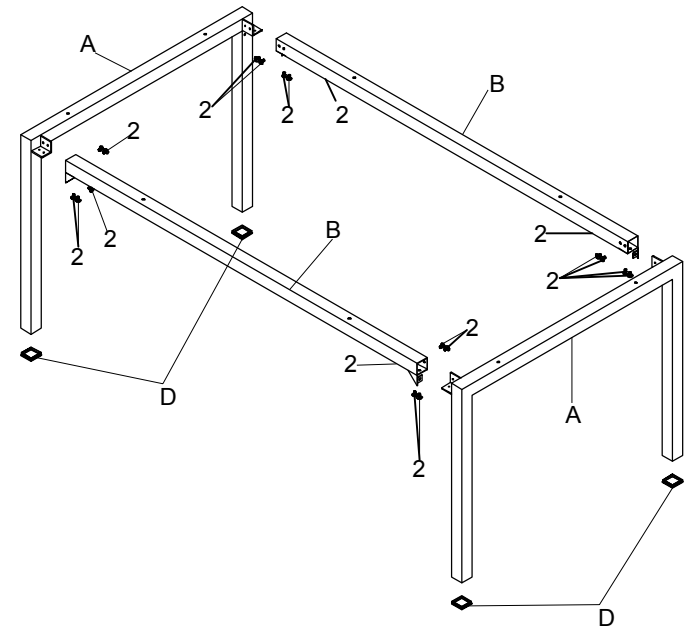

STEP 2

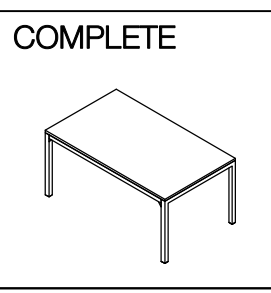
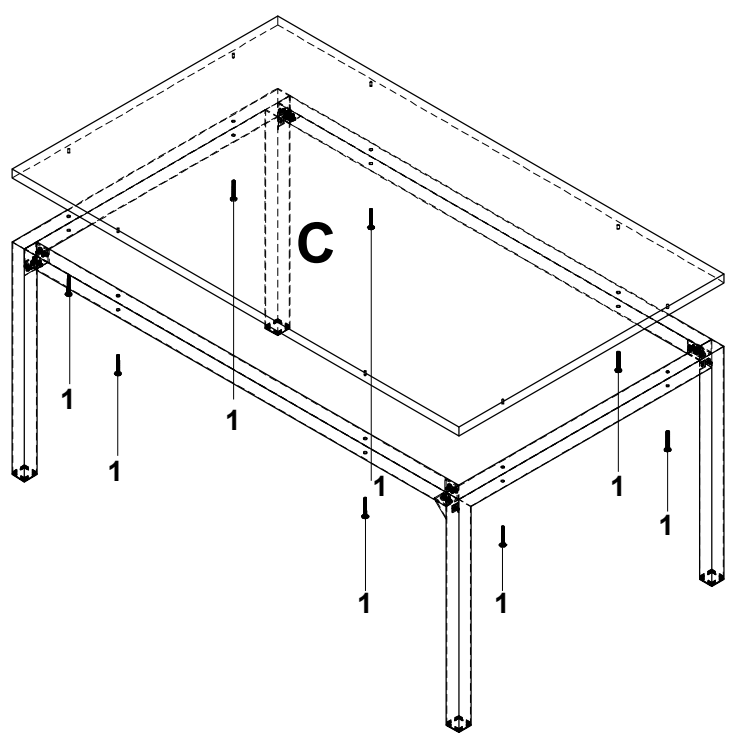

ITEM:110101 ASSEMBLY INSTRUCTIONS



Product Size : 1626 X 965 X 762 H (MM)
Product Size : 64" X 38" X 30"

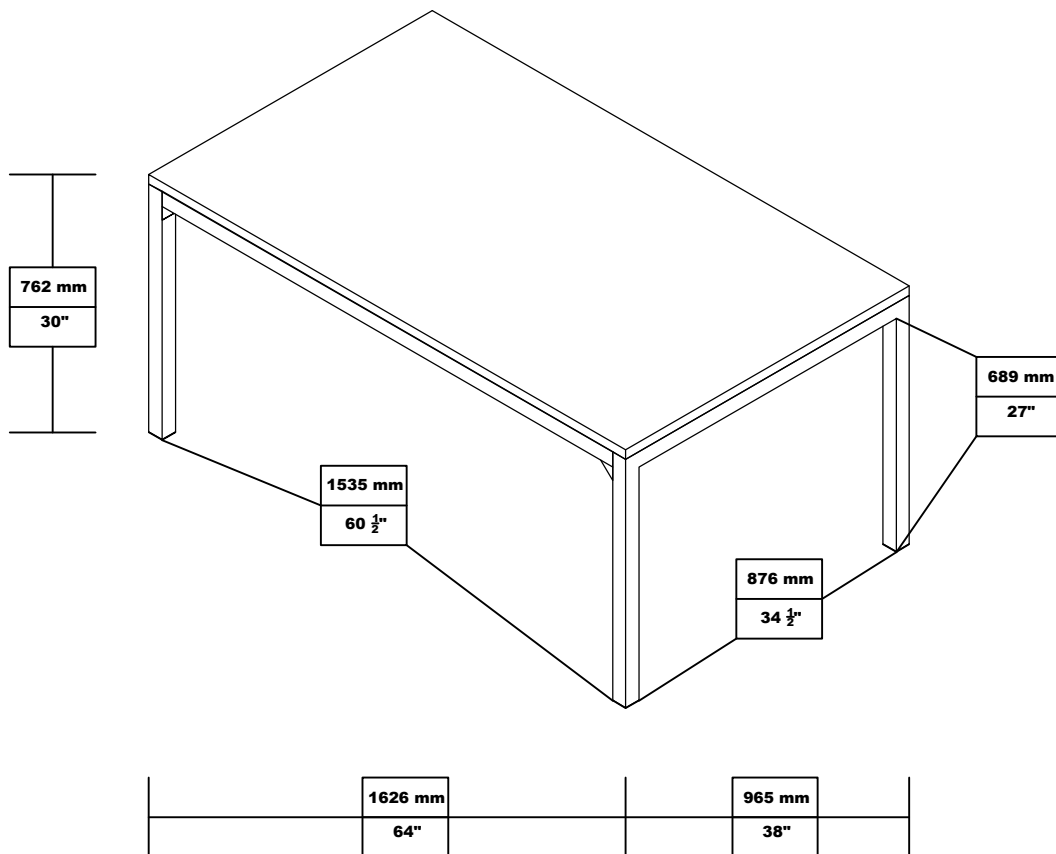

Note : Dimension tolerance $\pm 5\%$