

ASSEMBLY INSTRUCTIONS
COASTER FINE FURNITURE



Fine Furniture for every stage of life

300182QF
Queen & Full Size
Metal Headboard

ITEM:300182QF



ASSEMBLY INSTRUCTIONS

ASSEMBLY TIPS:

1. Remove hardware from box and sort by size.
2. Please check to see that all hardware and parts are present prior to start of assembly.
3. Please follow attached instructions in the same sequence as numbered to assure fast & easy assembly.



WARNING !



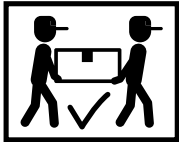

1. Don't attempt to repair or modify parts that are broken or defective. Please contact the store immediately.
2. This product is for home use only and not intended for commercial establishment.





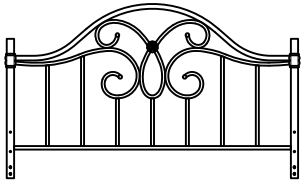





ASSEMBLY TIME

15 MINUTE

PARTS IDENTIFICATION

A HEADBOARD		1PC	C FINIALS		2PCS
B SUPPORT LEG		2PCS	D ADJUSTING PLATE		2PCS

HARDWARE IDENTIFICATION

1	BOLT (1/4"x2-1/4" - BLK)		4PCS	6	NUT (φ1/4"x8mm - BLK)		8PCS
2	BOLT (1/4"x7/8" - BLK)		4PCS	7	ALLEN KEY (4x22X60mm - BLK)		1PC
3	BOLT (1/4"x1/2" - BLK)		4PCS	8	WRENCH (11.3x12.5X55mm - WHT)		2PCS
4	WASHER (φ16mm - BLK)		12PCS	9	PLASTIC END CAP (φ28mm - BLK)		2PCS
5	WASHER (φ25mm - BLK)		8PCS				

NOTE:

Phillips head screw driver is required in the assembly process; however, manufacturer does not provide this item.

ITEM: **300182QF**



ASSEMBLY INSTRUCTIONS

STEP 1:

ASSEMBLY

Do not fully tighten all bolts until assembly is complete.
This will help all parts to assemble properly.

3		4PCS
7		

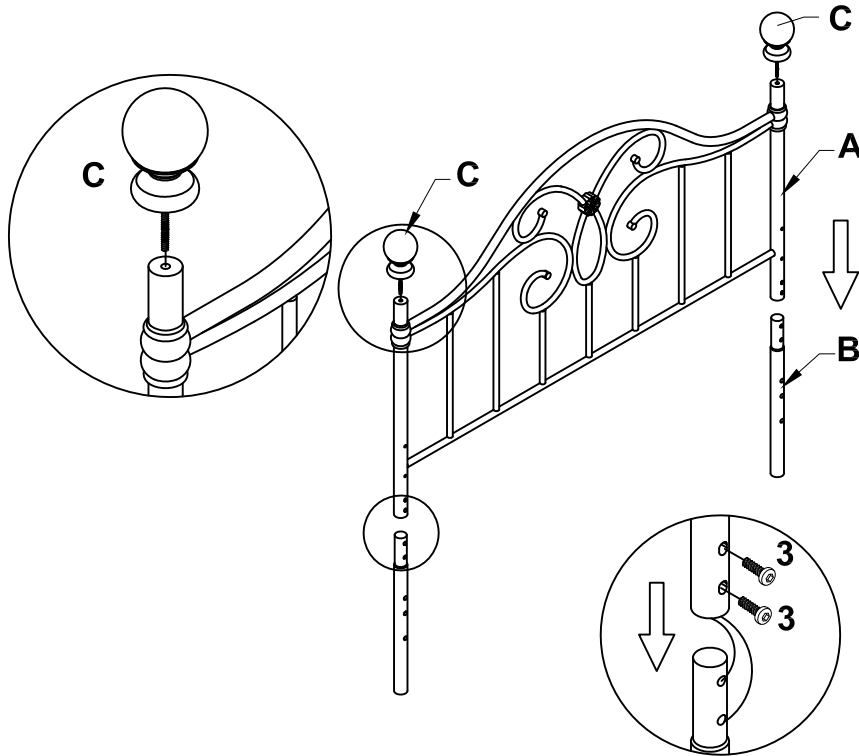

STEP 2:

60" ASSEMBLY INSTRUCTIONS

1		4PCS
4		4PCS
5		4PCS
6		4PCS
7		
8		

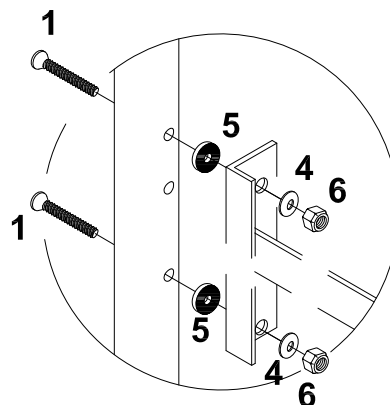
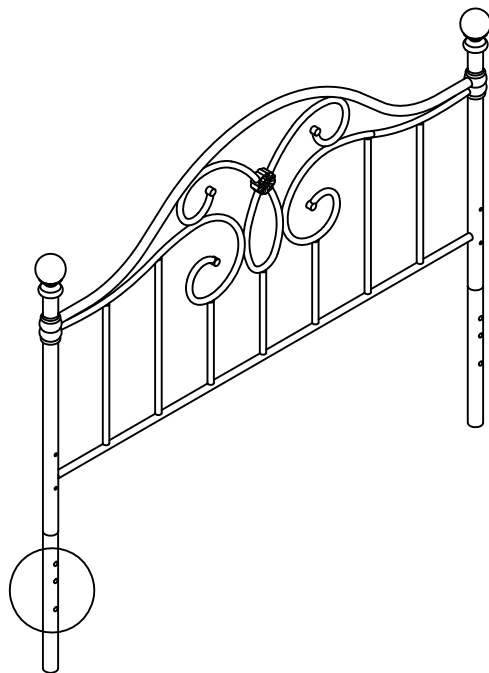

ITEM: **300182QF**

ASSEMBLY INSTRUCTIONS

STEP 3:

54" ASSEMBLY INSTRUCTIONS



- | | | |
|---|--|-------|
| 1 | | 4PCS |
| 2 | | 4PCS |
| 4 | | 12PCS |
| 5 | | 8PCS |
| 6 | | 8PCS |
| 7 | | |
| 8 | | |

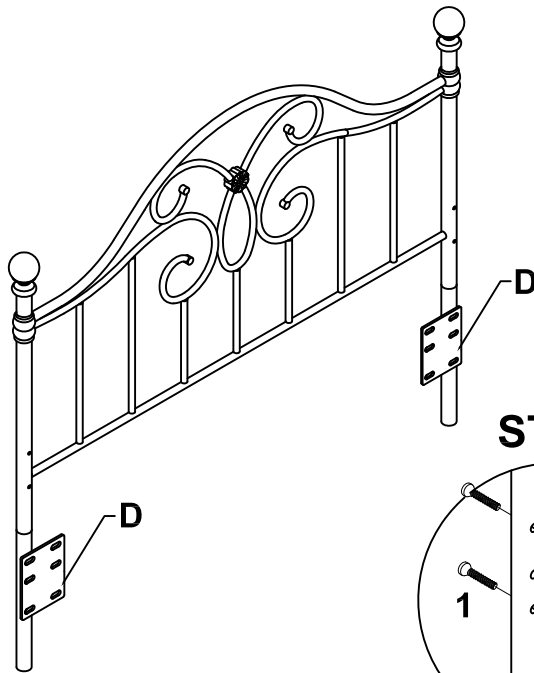

STEP 1

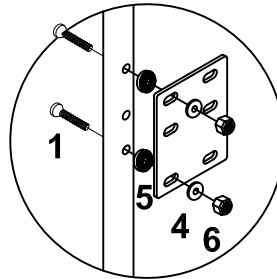

STEP 2

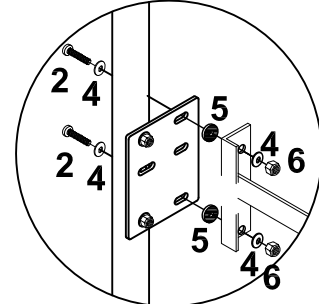

STEP 4:

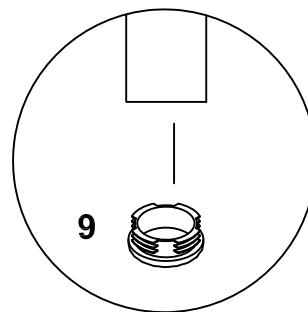
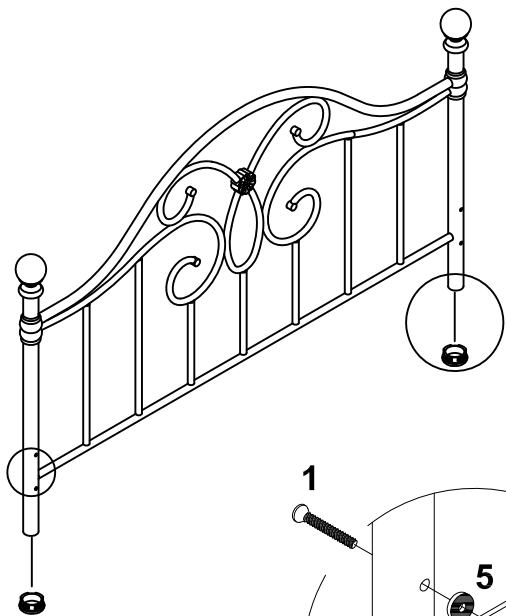

- | | | |
|---|--|------|
| 1 | | 4PCS |
| 4 | | 4PCS |
| 5 | | 4PCS |
| 6 | | 4PCS |
| 7 | | |
| 8 | | |
| 9 | | 2PCS |

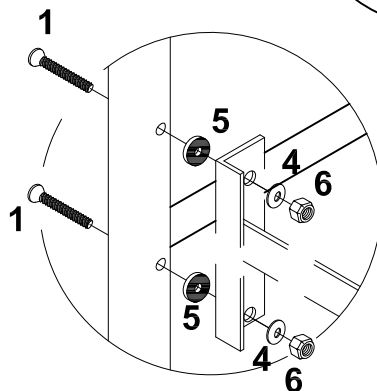

ITEM:300182QF

COASTER
FINE FURNITURE

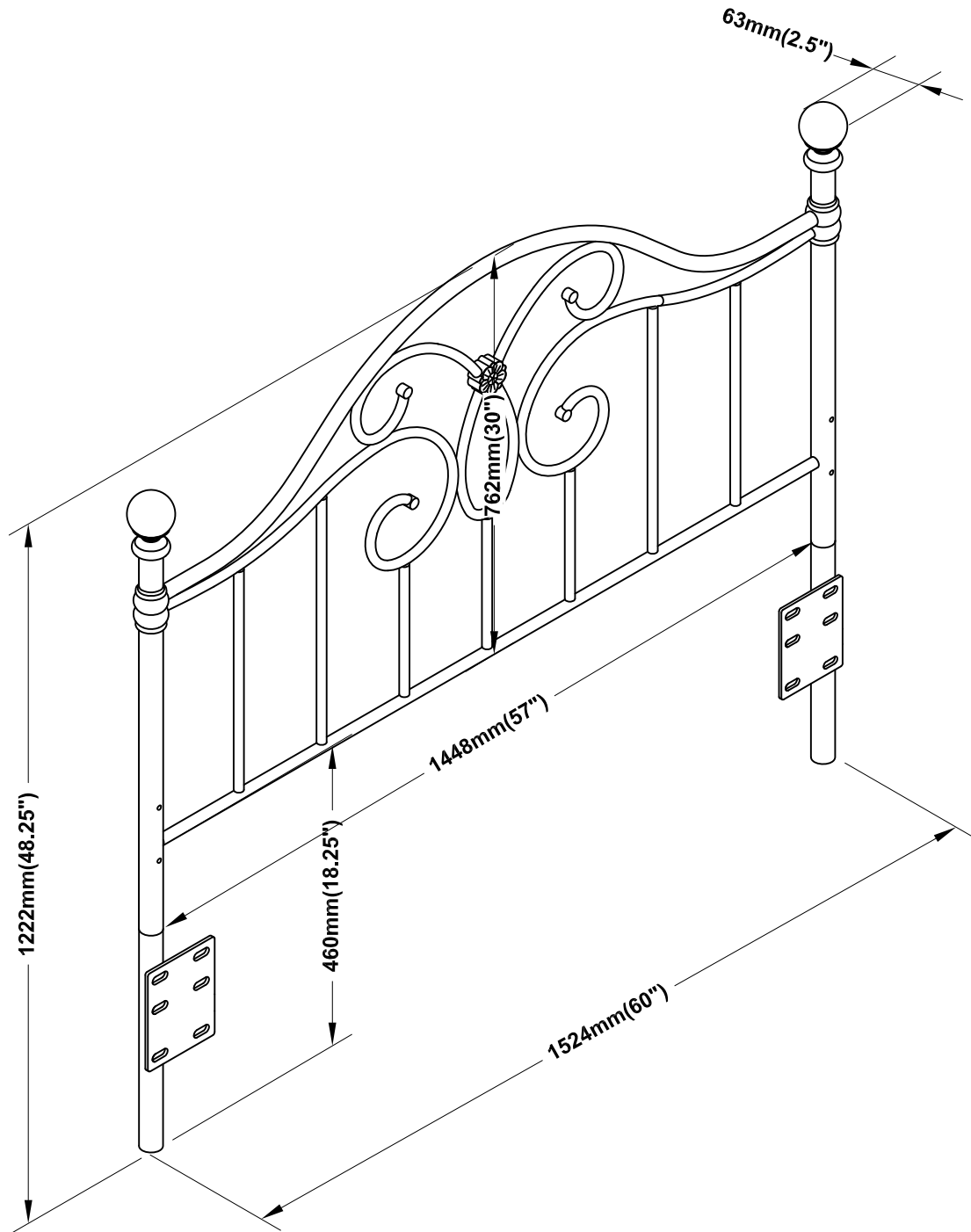

Note : Dimension tolerance $\pm 5\%$