

**ASSEMBLY INSTRUCTIONS**  
**COASTER FINE FURNITURE**



*Fine Furniture for every stage of life*

**200891KW (B1&B2)**  
**California King Bed**

REVISION 0 : 04/13/2016  
REVISION 1 : 08/15/2019

# ITEM: 200891KW (B1 & B2)

## ASSEMBLY INSTRUCTIONS

### ASSEMBLY TIPS:

1. Remove hardware from box and sort by size.
2. Please check to see that all hardware and parts are present prior to start of assembly.
3. Please follow attached instructions in the same sequence as numbered to assure fast & easy assembly.



### WARNING!

1. Don't attempt to repair or modify parts that are broken or defective. Please contact the store immediately.
2. This product is for home use only and not intended for commercial establishments.



ASSEMBLY TIME

14 MINUTES

## PARTS IDENTIFICATION

### B1 ( BOX 1 )

A HEADBOARD  
PANEL

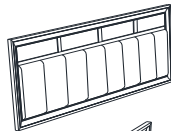

1PC

B FOOTBOARD

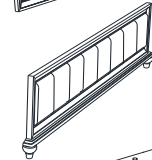

1PC

C RIGHT  
HEADBOARD  
LEG

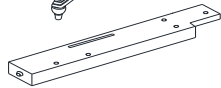

1PC

D LEFT  
HEADBOARD  
LEG

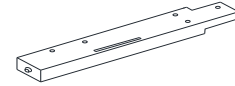

1PC

E BED SLAT

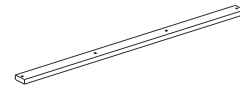

4PCS

F BED SLAT  
SUPPORT WITH  
LEVELER

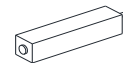

8PCS

### B2 ( BOX 2 )

G BED RAIL

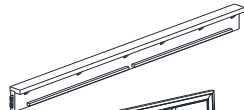

2PCS

HB  
200891KW(B1)  
FROM BOX 1  
HEADBOARD  
COMPLETE

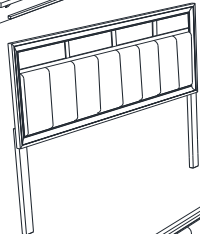

1PC

B  
200891KW(B1)  
FROM BOX 1  
FOOTBOARD

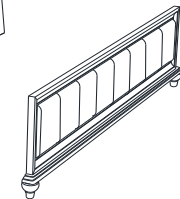

1PC

### NOTE:

Phillips head screw driver is required in the assembly process; however, manufacturer does not provide this item.

# ITEM: 200891KW (B1 & B2)

## ASSEMBLY INSTRUCTIONS

### ASSEMBLY TIPS:

1. Remove hardware from box and sort by size.
2. Please check to see that all hardware and parts are present prior to start of assembly.
3. Please follow attached instructions in the same sequence as numbered to assure fast & easy assembly.







### WARNING!

1. Don't attempt to repair or modify parts that are broken or defective. Please contact the store immediately.
2. This product is for home use only and not intended for commercial establishments.

## HARDWARE IDENTIFICATION

### Z-B1 (BOX 1) - HARDWARE PACK IS LOCATED IN 200891KW (B1)

1	<b>BOLT</b> (M6 x 30mm - BLK)		6PCS	5	<b>FLAT HEAD SCREW</b> (M4 x 32mm - RBW)		8PCS
2	<b>LOCK WASHER</b> (1/4" - BLK)		6PCS				
3	<b>FLAT WASHER</b> (1/4" ID x 13mm - BLK)		6PCS				
4	<b>ALLEN WRENCH</b> (M4 x 60mm - BLK)		1PC				

### NOTE:

Phillips head screw driver is required in the assembly process; however, manufacturer does not provide this item.

**ASSEMBLY INSTRUCTIONS**

**STEP 1**

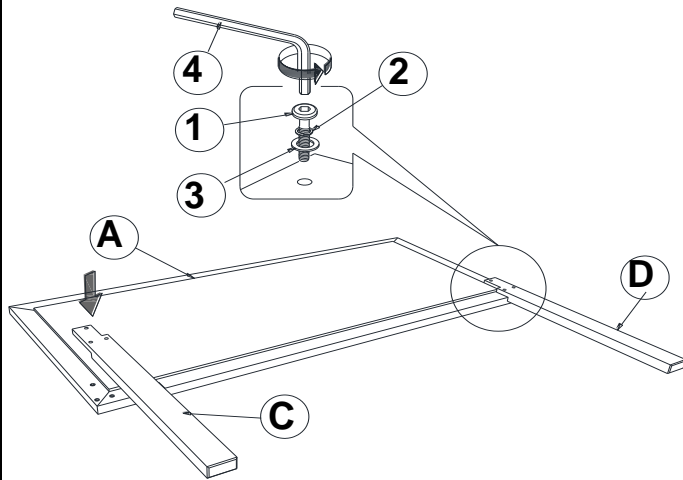

**\*\*BACK VIEW\*\***

Note : Please take note of the marking sticker (L&R) on the leg.

**STEP 2**

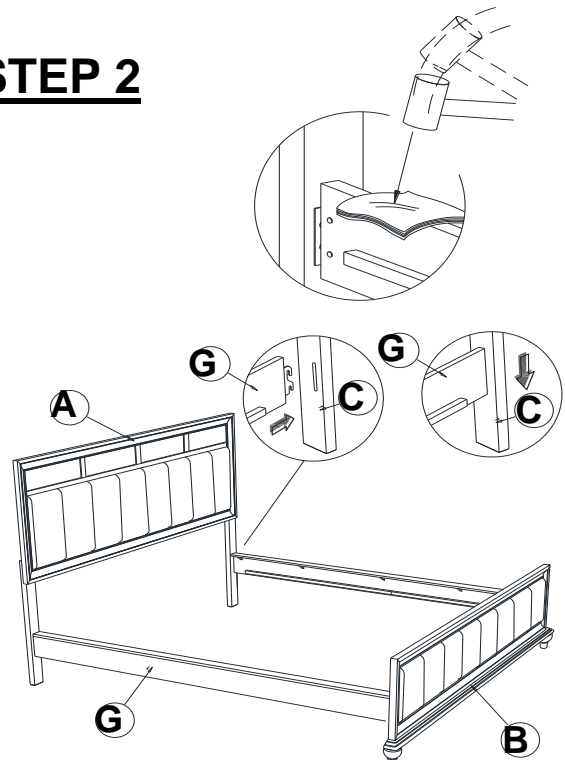

**Note :** Make sure the protective cloth is sufficient enough to protect bed rail(G) before hammering.

**STEP 3**

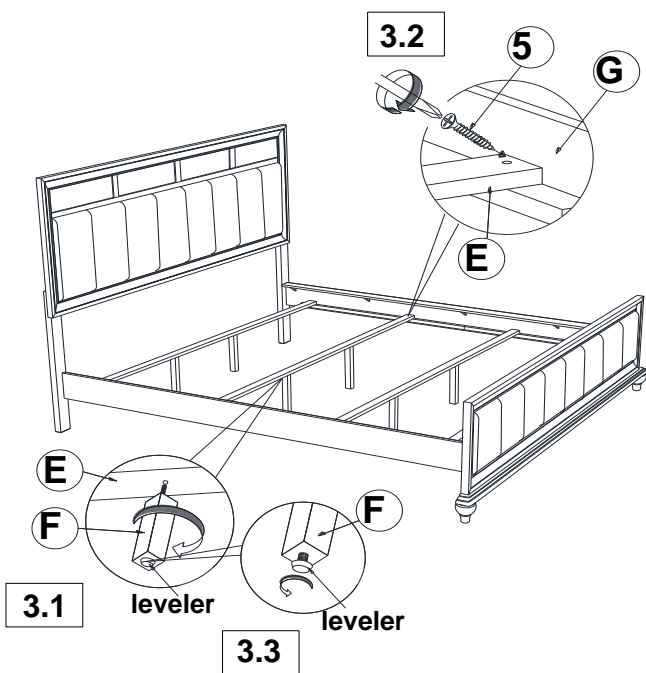

**STEP 4**  
**COMPLETE**

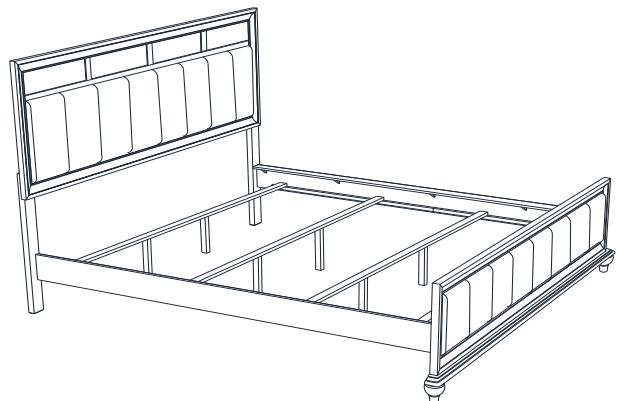

# ITEM: 200891KW (B1&B2)

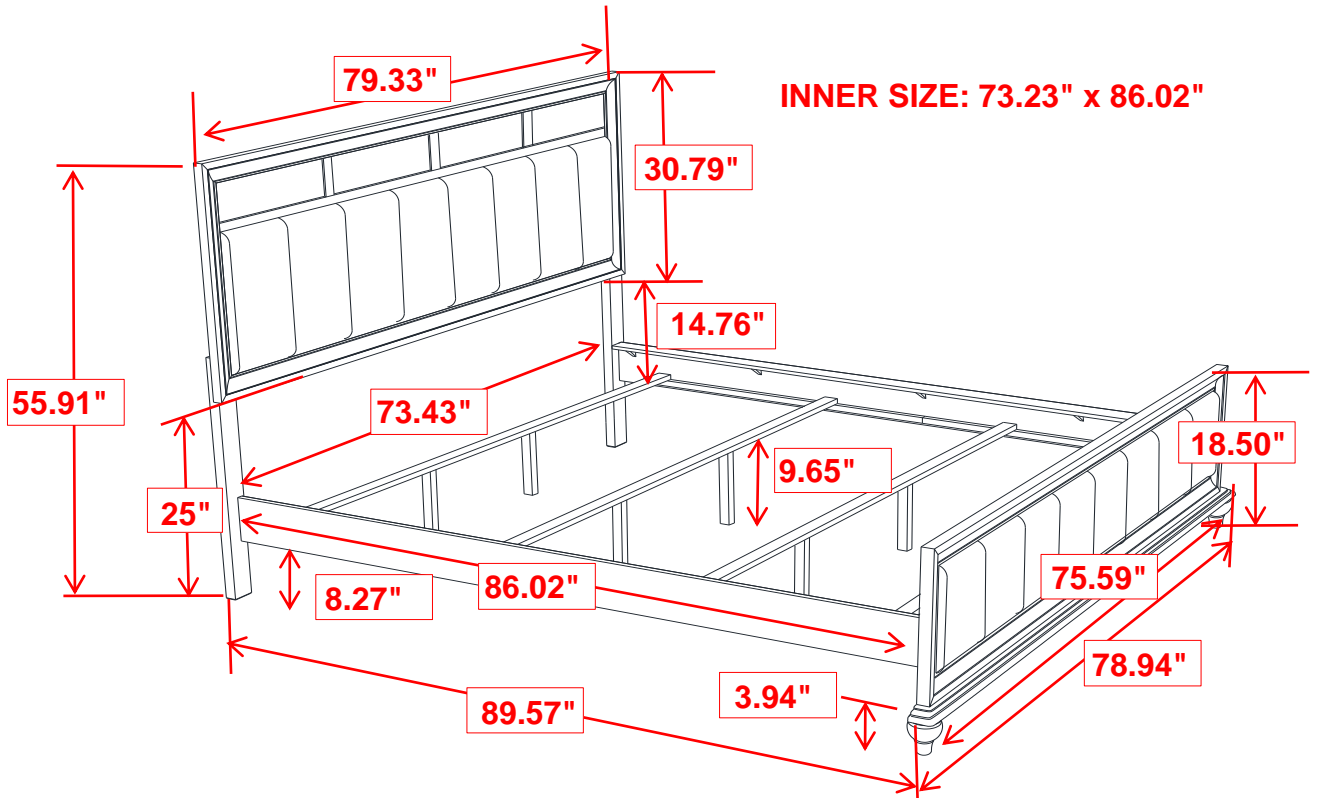

**Note :** Dimension tolerance  $\pm 5\%$