

ASSEMBLY INSTRUCTIONS
COASTER FINE FURNITURE

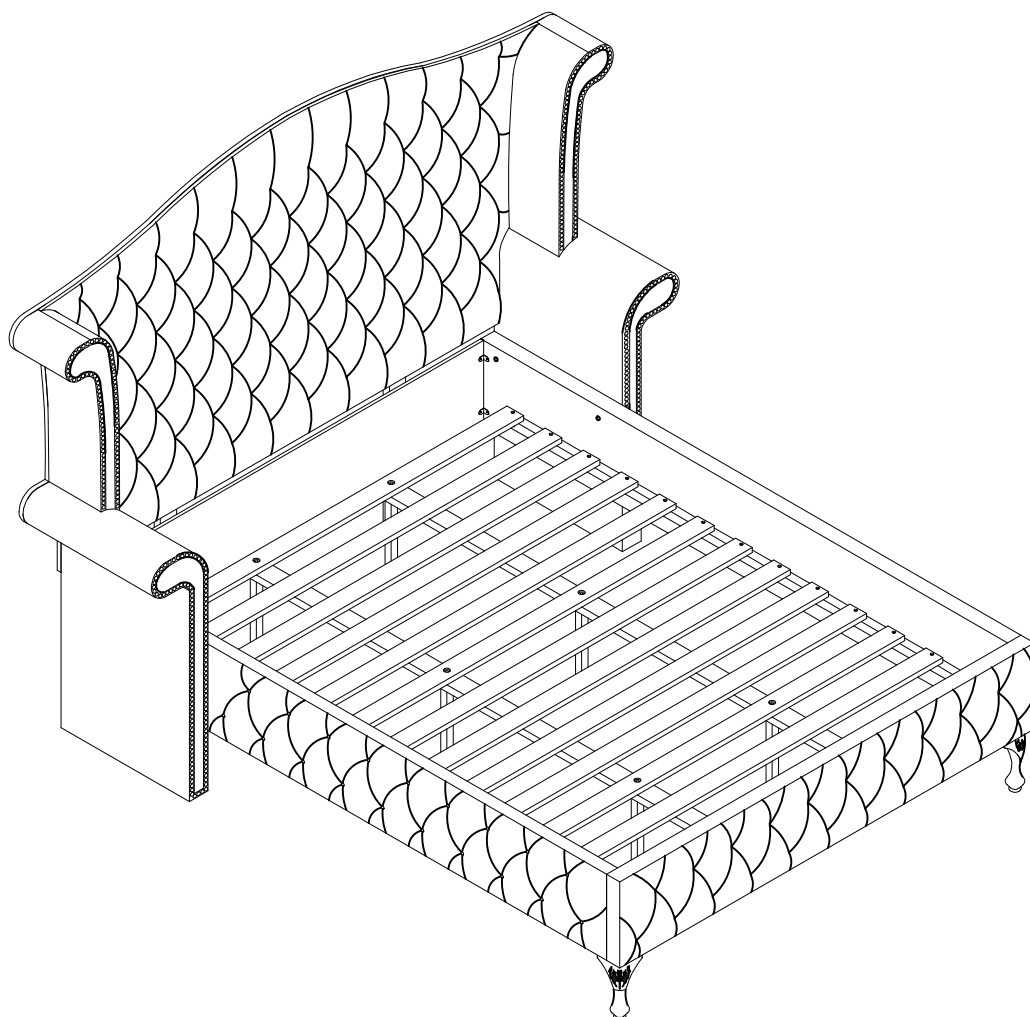

Fine Furniture for every stage of life

205101KE (B1-B3)
Eastern King Bed

REVISION 0 : 11/28/2016
REVISION 1 : 10/17/2017
REVISION 2 : 06/05/2018
REVISION 3 : 09/04/2019

ITEM: 205101KE (B1-B3)



ASSEMBLY INSTRUCTIONS

ASSEMBLY TIPS:

1. Remove hardware from box and sort by size.
2. Please check to see that all hardware and parts are present prior to start of assembly.
3. Please follow attached instructions in the same sequence as numbered to assure fast & easy assembly.



WARNING!

1. Don't attempt to repair or modify parts that are broken or defective. Please contact the store immediately.
2. This product is for home use only and not intended for commercial establishments.





ASSEMBLY TIME



40 MINUTES

PARTS IDENTIFICATION





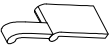





B1 (BOX 1)

AV	HEADBOARD		1PC	CV	HEADBOARD PANEL		1PC
BV	HEADBOARD SUPPORT LEG		2PCS				

B2 (BOX 2)

DV1	RIGHT EAR PANEL		1PC	EV	EAR PANEL SUPPORT		2PCS
DV2	LEFT EAR PANEL		1PC				

B3 (BOX 3)

FV	FOOTBOARD		1PC	KV	FOOTBOARD LEG		2PCS
GV1	LEFT BED RAIL		1PC	LV	CENTER RAIL		2PCS
GV2	RIGHT BED RAIL		1PC	MV	CENTER RAIL SUPPORT		2PCS
HV	BED SLAT		10PCS	HBV	205101KE (B1) FROM BOX 1 HEADBOARD COMPLETE		1PC
IV	BED SLAT WITH HOLES		3PCS	ERV	205101KE (B2) FROM BOX 2 LEFT AND RIGHT EAR PANEL COMPLETE		2PCS
JV	BED SLAT SUPPORT		6PCS				

NOTE:

Phillips head screw driver is required in the assembly process; however, manufacturer does not provide this item.

ITEM: 205101KE (B1-B3)



ASSEMBLY INSTRUCTIONS

ASSEMBLY TIPS:

1. Remove hardware from box and sort by size.
2. Please check to see that all hardware and parts are present prior to start of assembly.
3. Please follow attached instructions in the same sequence as numbered to assure fast & easy assembly.















WARNING!

1. Don't attempt to repair or modify parts that are broken or defective. Please contact the store immediately.
2. This product is for home use only and not intended for commercial establishments.

HARDWARE IDENTIFICATION

Z-B3 (BOX 3) - HARDWARE PACK IS LOCATED IN 205101KE (B3)

1	ALLEN WRENCH (4MM - RBW)		1PC	7	MEDIUM PAN HEAD SCREW (#4 x 25mm - RBW)		4PCS
2	BOLT 1 (Ø1/4" x 30mm - RBW)		4PCS	8	LONG PAN HEAD SCREW (#4 x 38mm - RBW)		32PCS
3	BOLT 2 (Ø1/4" x 38mm - RBW)		10PCS	9	BIG FLAT WASHER (Ø1/4" X 25 X 1.5mm - RBW)		22PCS
4	BOLT 3 (Ø1/4" x 60mm - RBW)		10PCS	10	SMALL FLAT WASHER (Ø1/4" X 19 X 1.5mm - RBW)		22PCS
5	BOLT 4 (Ø1/4" x 90mm - RBW)		8PCS	11	LOCK WASHER (Ø1/4" - RBW)		22PCS
6	SHORT PAN HEAD SCREW (#4 x 20mm - RBW)		4PCS	12	LEVELER (Ø1/4" X 25mm - BLK)		6PCS

NOTE:

Phillips head screw driver is required in the assembly process; however, manufacturer does not provide this item.

ASSEMBLY INSTRUCTIONS

STEP 1

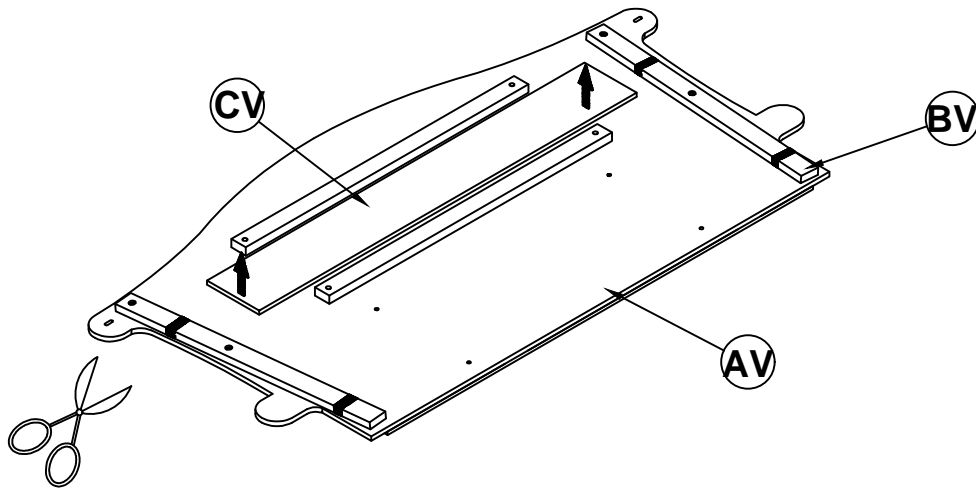

STEP 2

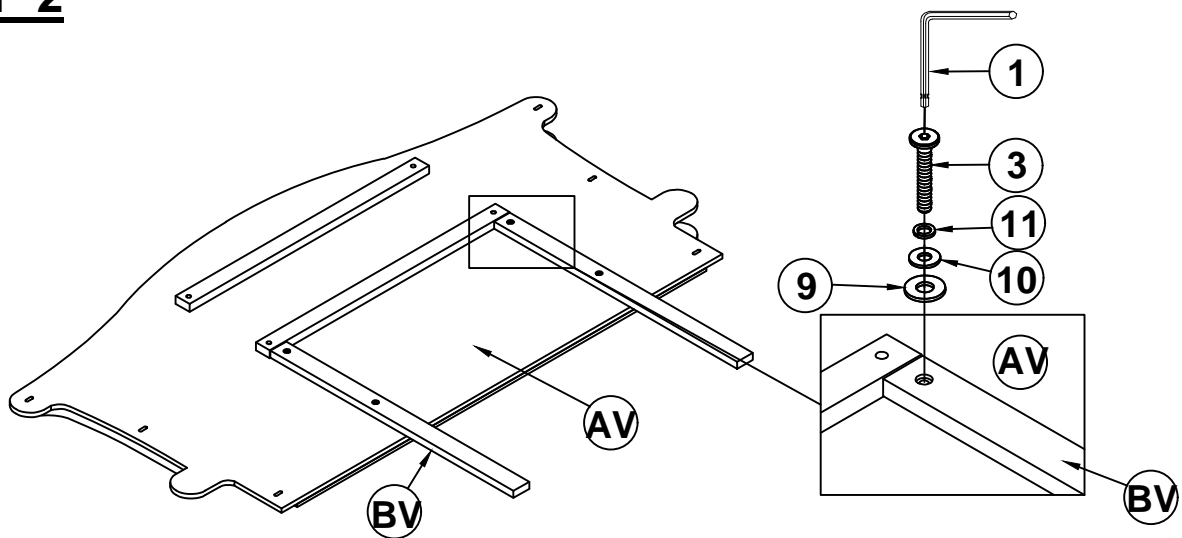

STEP 3

NOTE : THE EAR PANELSUPPORTS ARE TO LIFT UP THE BED RAILS

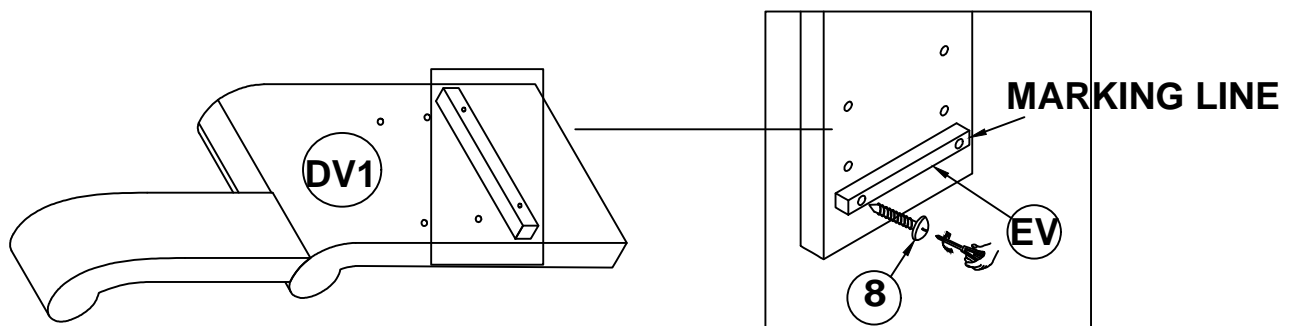

ASSEMBLY INSTRUCTIONS

STEP 4

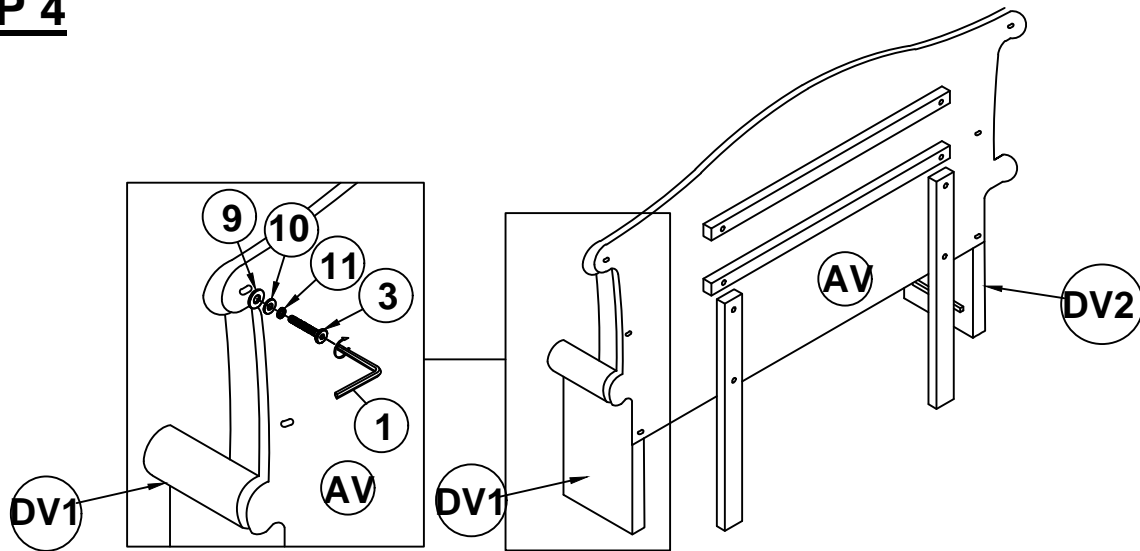

STEP 5

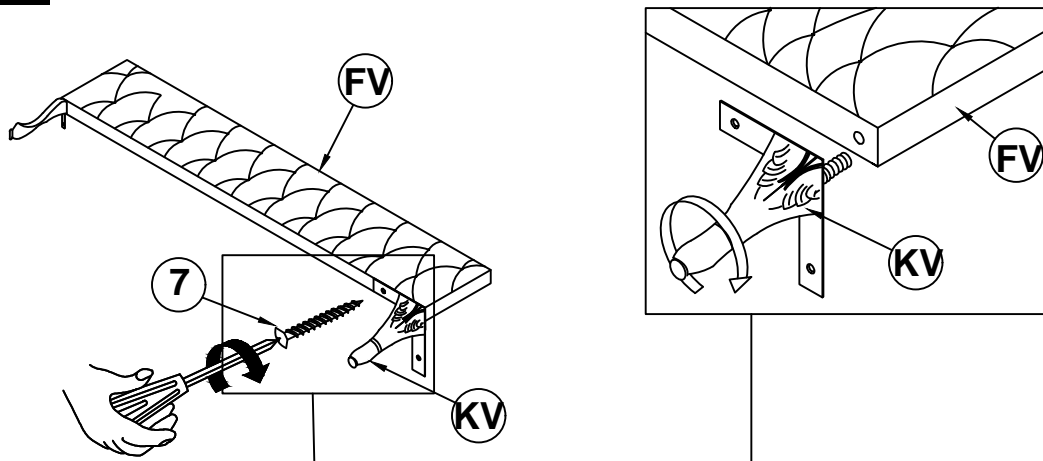

STEP 6

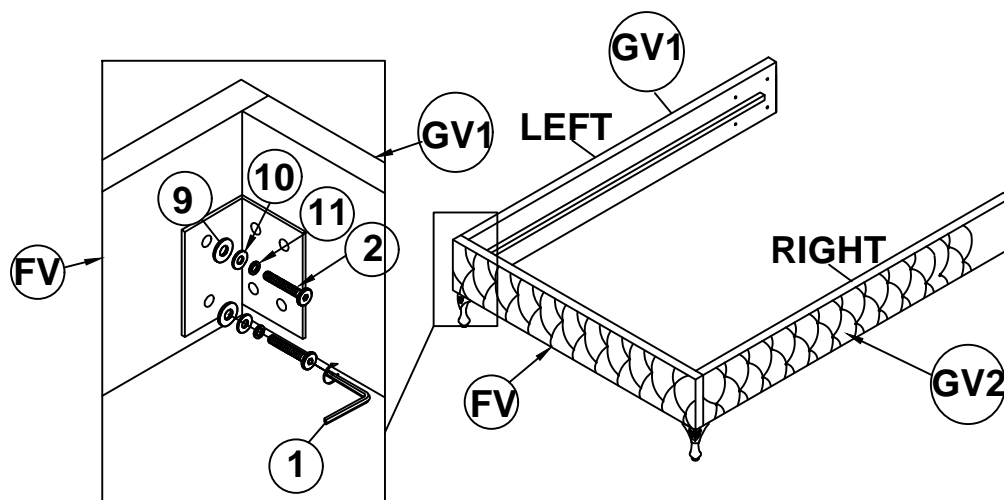

ASSEMBLY INSTRUCTIONS

STEP 7

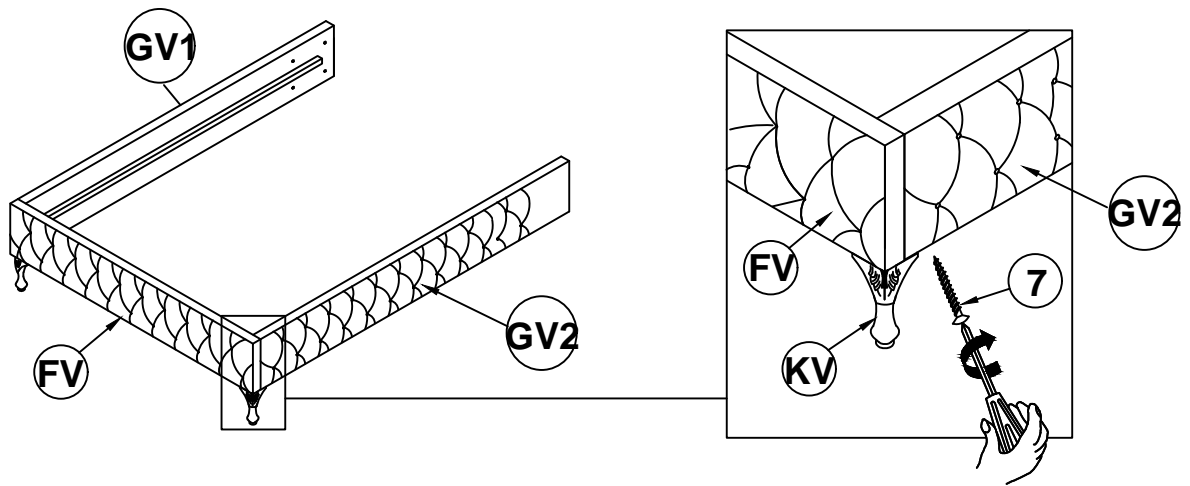

STEP 8

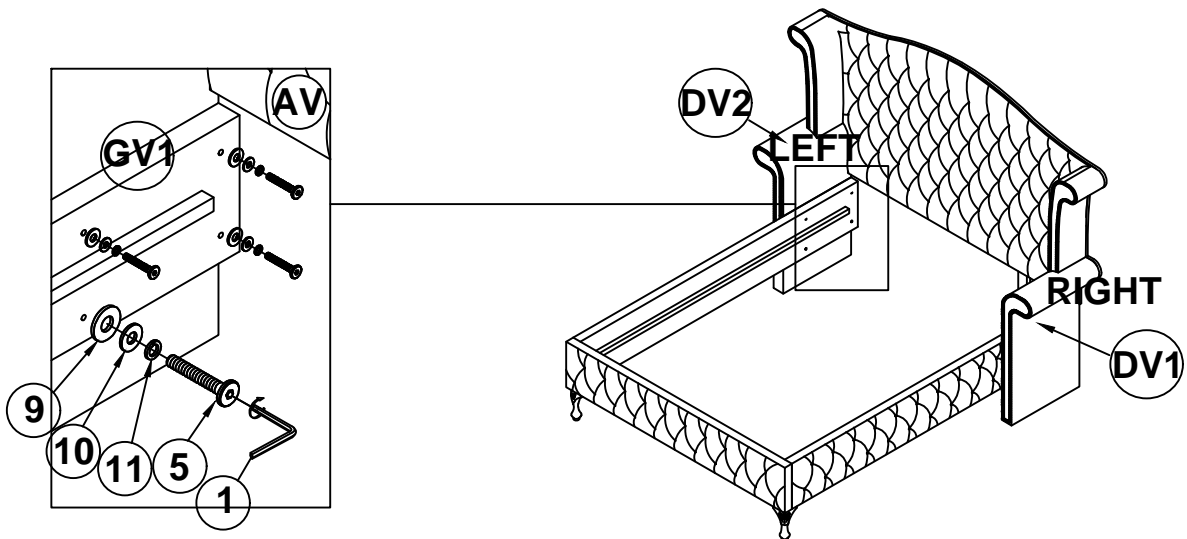

STEP 9

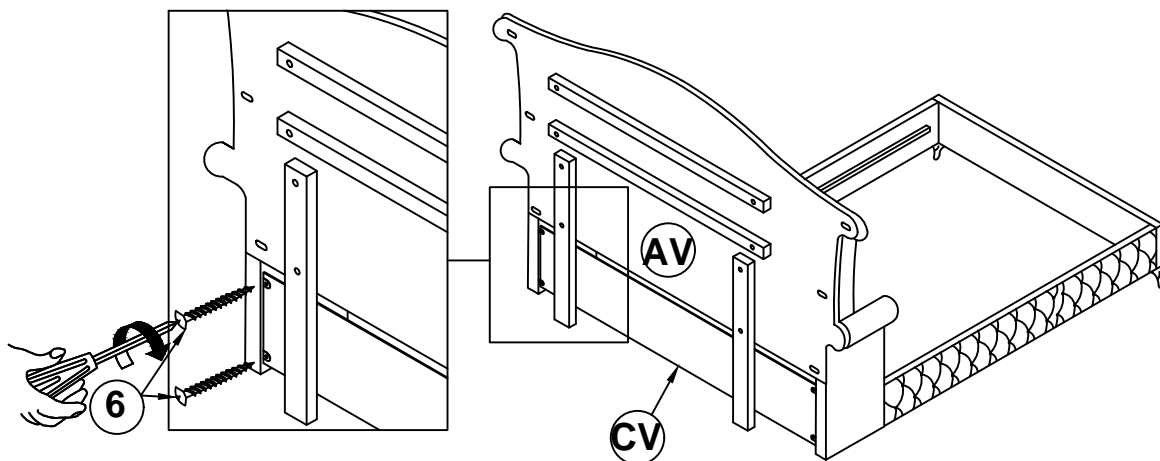

ASSEMBLY INSTRUCTIONS

STEP 10

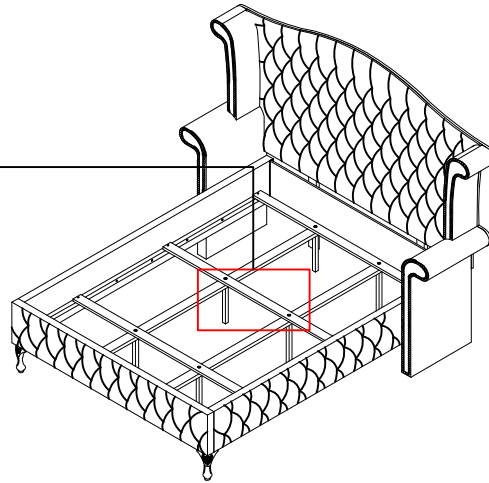
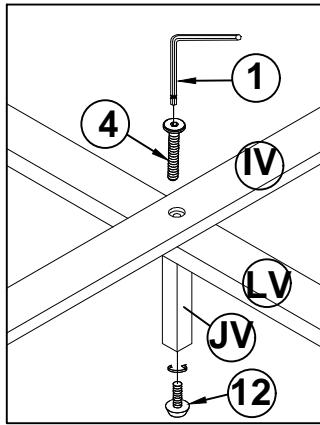

STEP 11

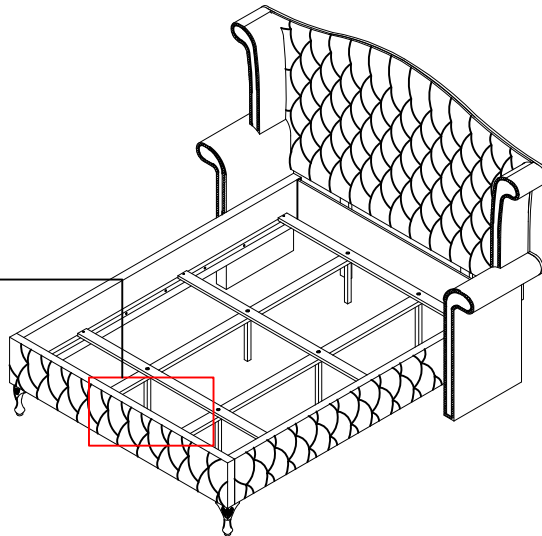
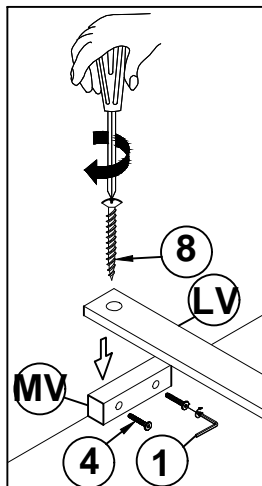

STEP 12

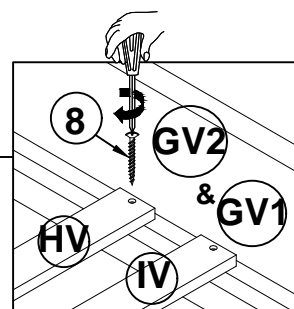
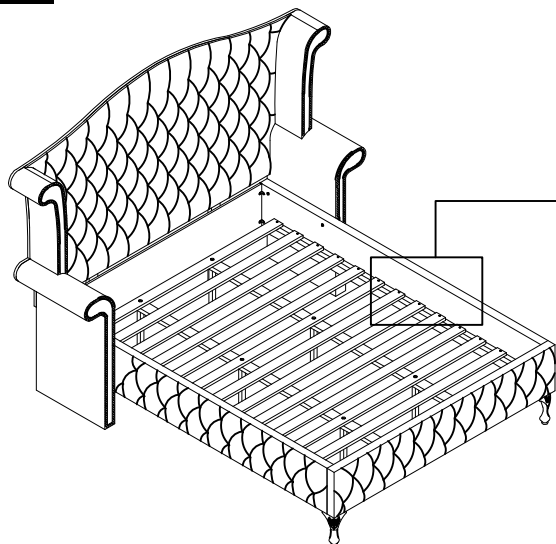

ITEM: **205101KE (B1-B3)**



ASSEMBLY INSTRUCTIONS

STEP 13

COMPLETE

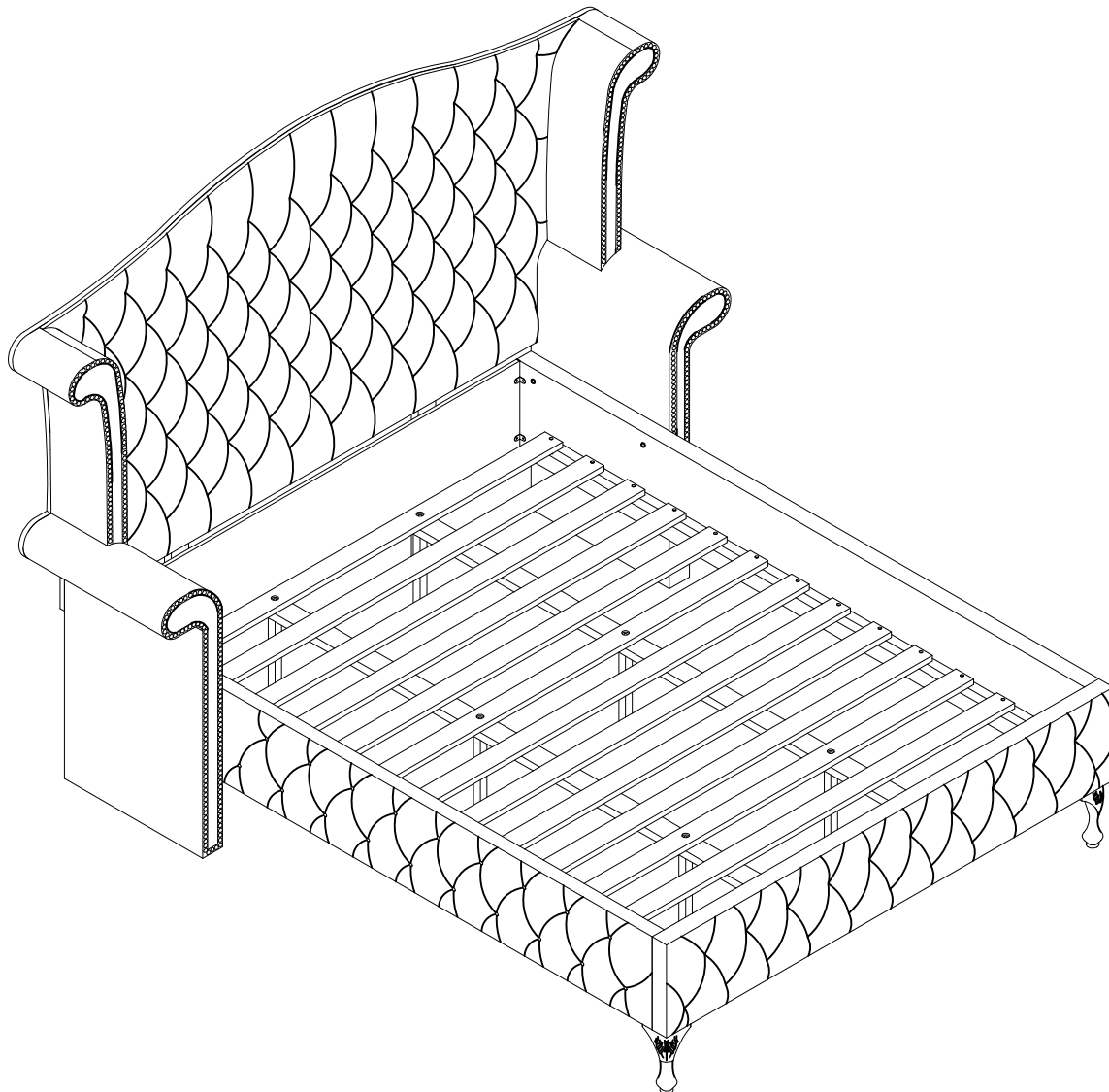

ITEM: 205101KE (B1-B3)



INNER SIZE : 77.05" X 81.1"

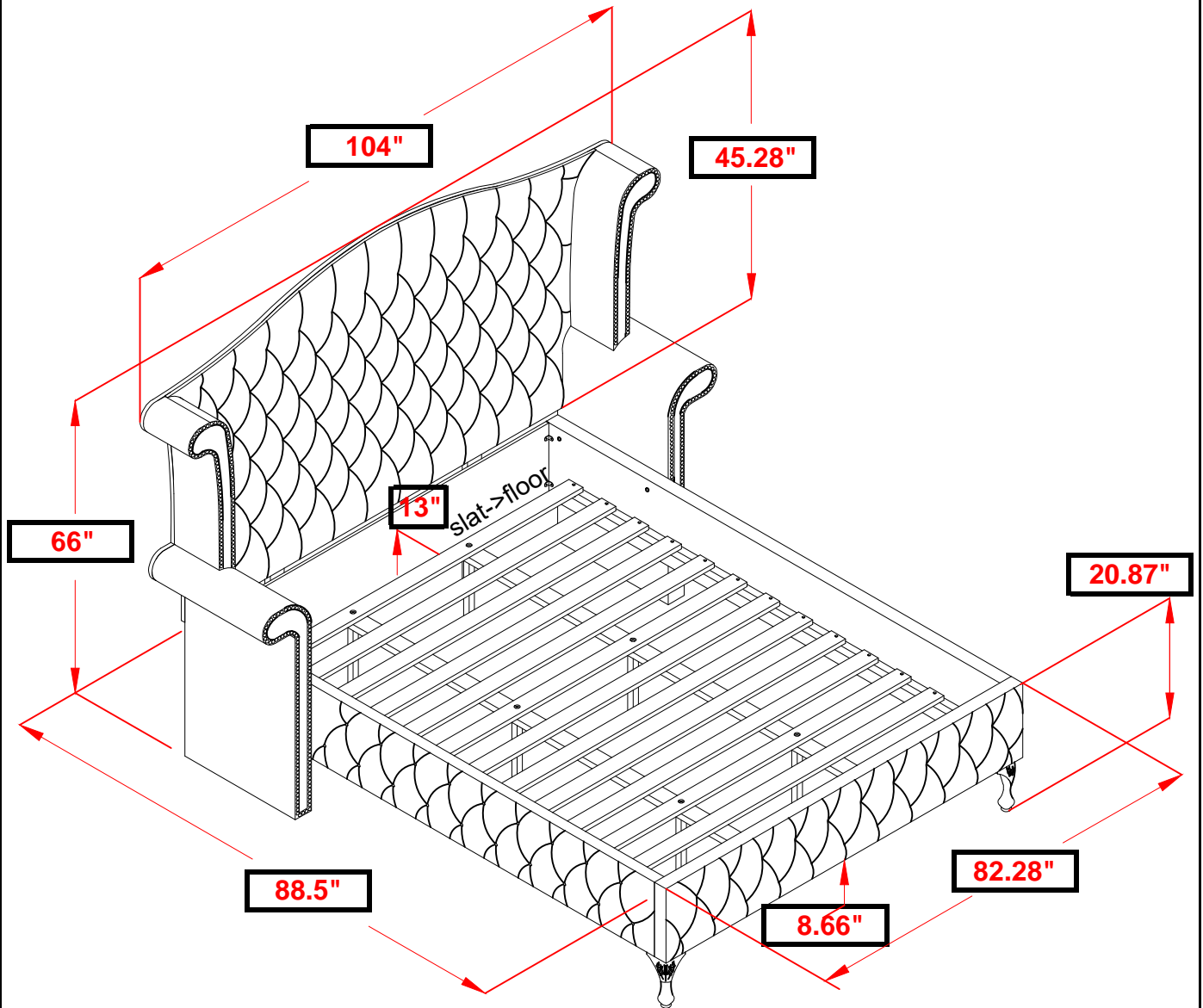

Note : Dimension tolerance $\pm 5\%$