

*ASSEMBLY INSTRUCTIONS*  
*COASTER FINE FURNITURE*

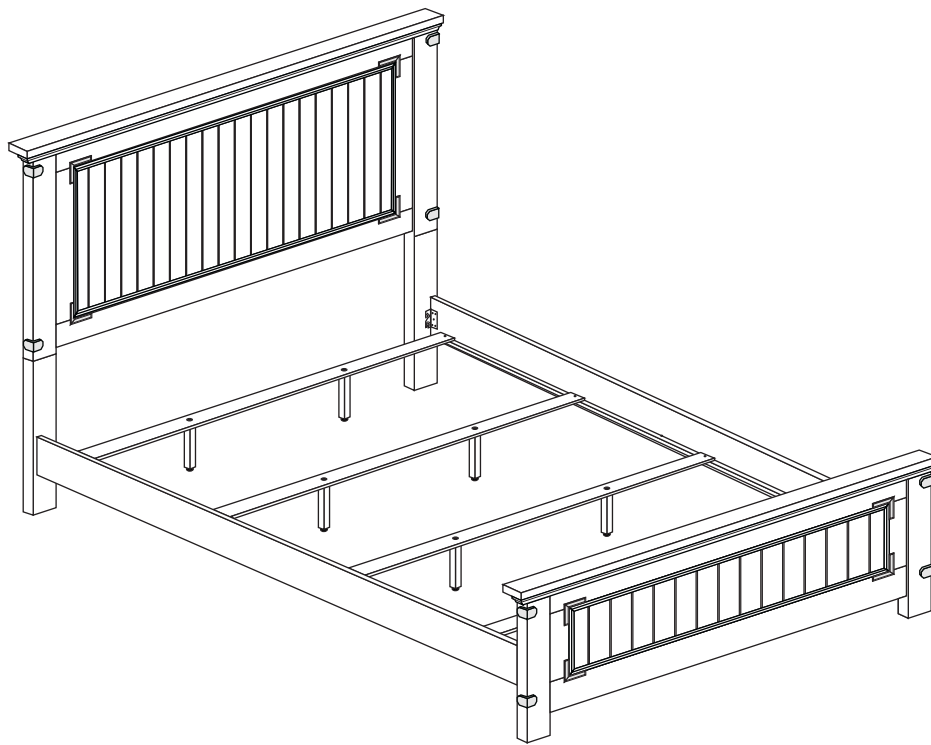

*Fine Furniture for every stage of life*

**205261KW (B1 & B2)**  
**California King Bed**

REVISION 0:07/27/2016  
REVISION 1:11/20/2018  
REVISION 2:01/14/2020

COASTERFURNITURE.COM

# ITEM: 205261KW (B1 & B2)

## ASSEMBLY INSTRUCTIONS



### ASSEMBLY TIPS:

1. Remove hardware from box and sort by size.
2. Please check to see that all hardware and parts are present prior to start of assembly.
3. Please follow attached instructions in the same sequence as numbered to assure fast & easy assembly.



### WARNING!

1. Don't attempt to repair or modify parts that are broken or defective. Please contact the store immediately.
2. This product is for home use only and not intended for commercial establishments.

**ASSEMBLY TIME**

**20 MINUTES**

## PARTS IDENTIFICATION

### B1 (BOX 1)

A HEADBOARD PANEL

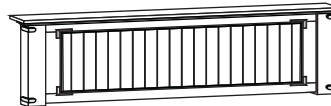

1PC

B RIGHT HEADBOARD LEG



1PC

C LEFT HEADBOARD LEG



1PC

D WOOD CLEAT



2PCS

E FOOTBOARD

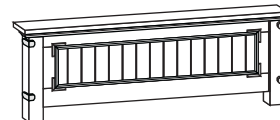

1PC

### B2 (BOX 2)

F BED RAIL



2PCS

G BED SLAT



4PCS

H BED SLAT SUPPORT WITH LEVELER



8PCS

HB 205261KW (B1)  
FROM BOX 1  
HEADBOARD COMPLETE

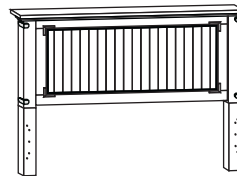

1PC

E 205261KW (B1)  
FROM BOX 1  
FOOTBOARD

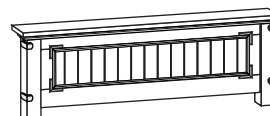

1PC

# ITEM:205261KW (B1 & B2)



## ASSEMBLY INSTRUCTIONS

### ASSEMBLY TIPS:

1. Remove hardware from box and sort by size.
2. Please check to see that all hardware and parts are present prior to start of assembly.
3. Please follow attached instructions in the same sequence as numbered to assure fast & easy assembly.











### WARNING!

1. Don't attempt to repair or modify parts that are broken or defective. Please contact the store immediately.
2. This product is for home use only and not intended for commercial establishments.

## HARDWARE IDENTIFICATION

### Z-B2 (BOX 2) - HARDWARE PACK IS LOCATED IN 205261KW (B2)

1	<b>LONG BOLT</b> (M6 x 40mm - RBW)		20PCS
2	<b>SHORT BOLT</b> (M8 x 20mm - RBW)		8PCS
3	<b>BIG FLAT WASHER</b> (5/16" x 22mm - RBW)		8PCS
4	<b>SMALL FLAT WASHER</b> (M6 x 13mm - RBW)		12PCS
5	<b>LOCK WASHER</b> (M6 x 13mm - RBW)		12PCS
6	<b>FLAT HEAD SCREW</b> (M4 x 30mm - RBW)		8PCS
7	<b>SMALL ALLEN WRENCH</b> (M4 x 58mm- BLK)		1PC
8	<b>BIG ALLEN WRENCH</b> (M5 x 67mm- BLK)		1PC

### NOTE :

Phillips head screw driver is required in the assembly process; however, manufacturer does not provide this item.

# ITEM: 205261KW (B1 & B2)

## ASSEMBLY INSTRUCTIONS



### STEP 1

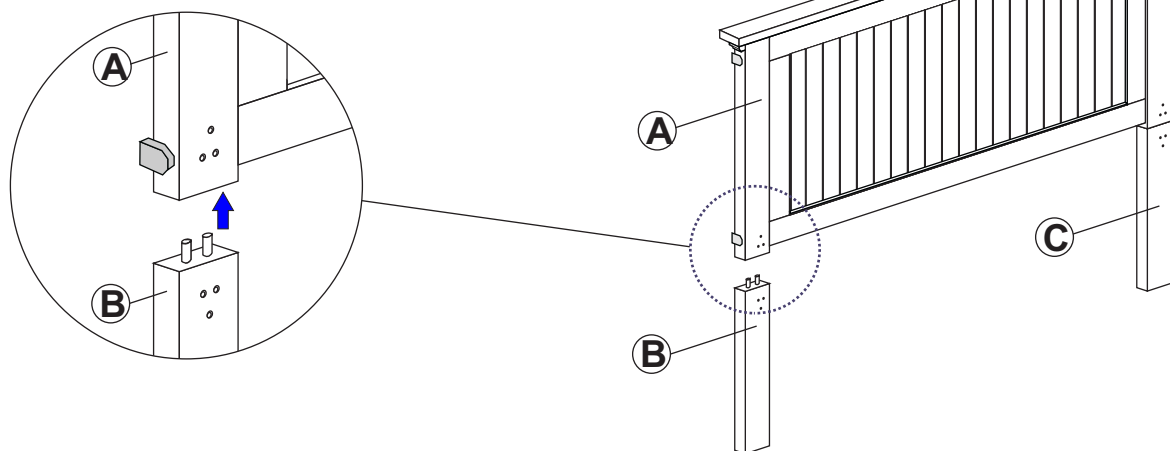

### STEP 2

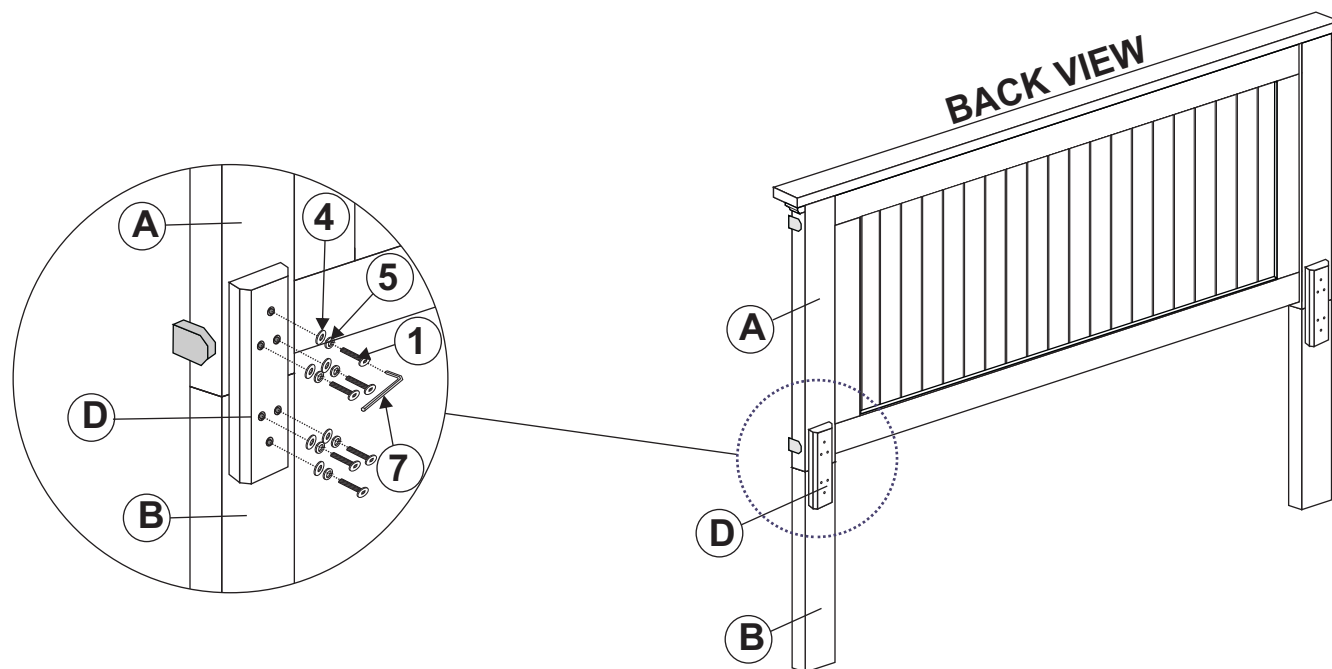

# ITEM: 205261KW (B1 & B2)

## ASSEMBLY INSTRUCTIONS



### STEP 3

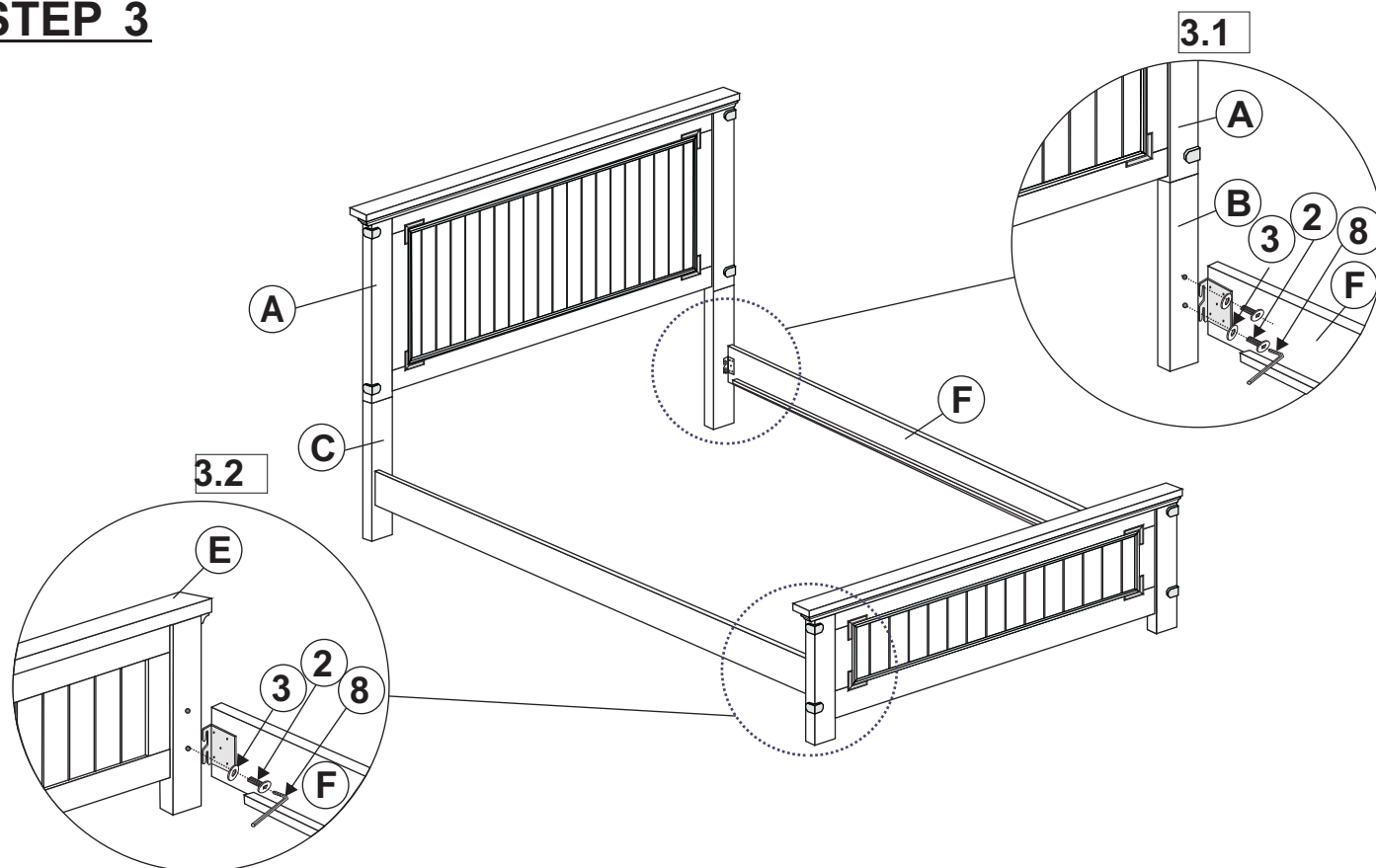

### STEP 4

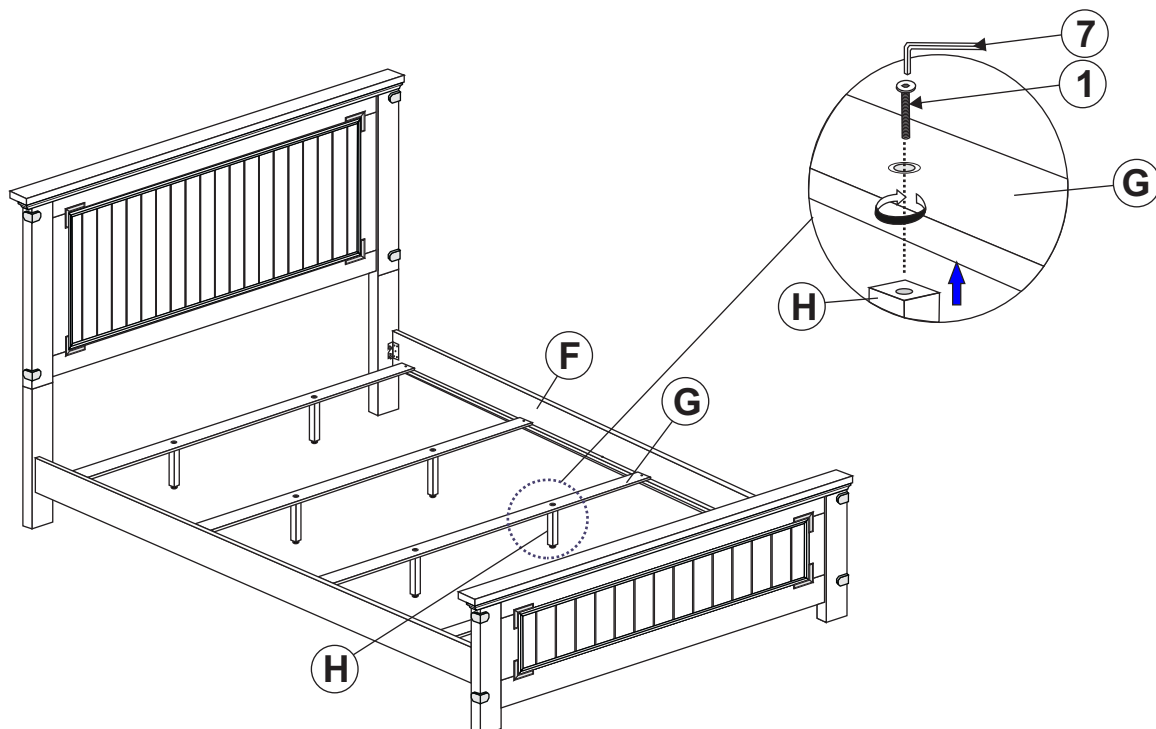

# ITEM: 205261KW (B1 & B2)

## ASSEMBLY INSTRUCTIONS



### STEP 5

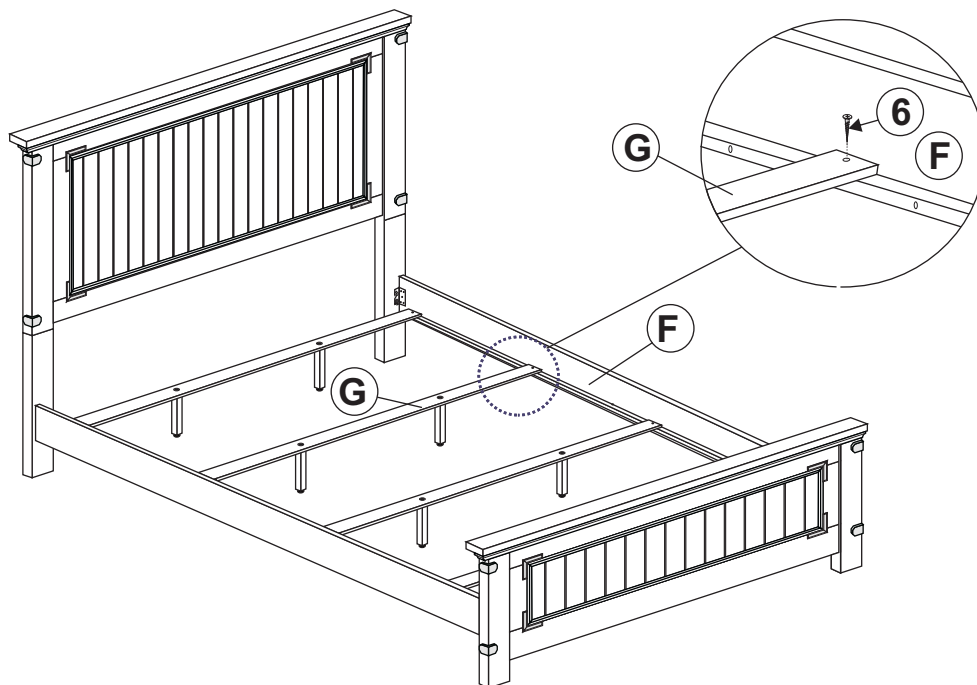

### STEP 6

### COMPLETE

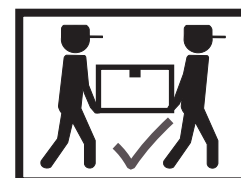
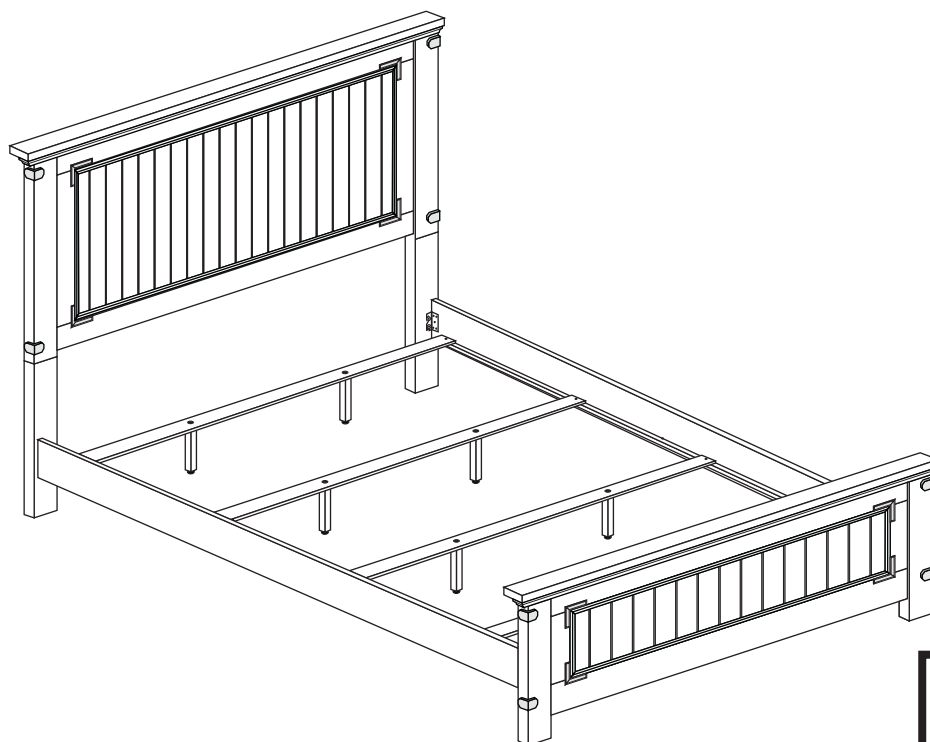

ITEM:205261KW (B1 & B2)

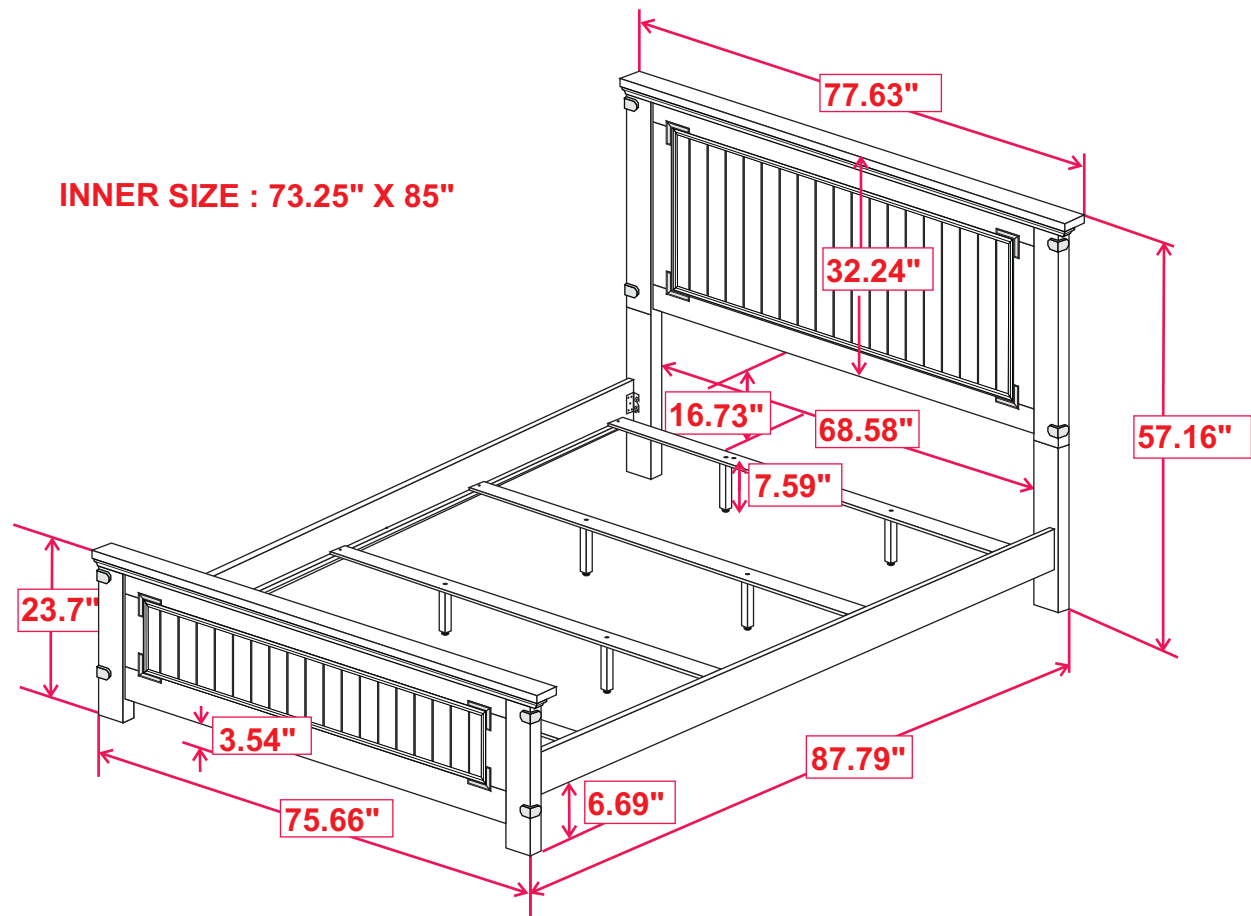

Note : Dimension tolerance  $\pm 5\%$