

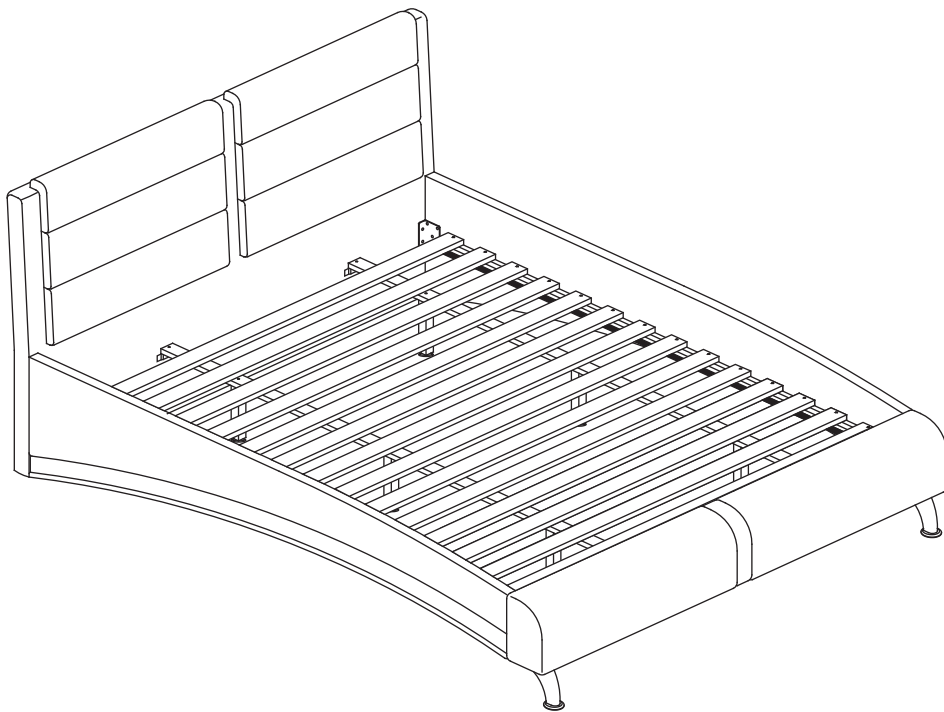

ASSEMBLY INSTRUCTIONS COASTER FINE FURNITURE



Fine Furniture for every stage of life

300350KE (B1-B3) *Eastern King Bed*

REVISION 0 : 08/13/2014
REVISION 1 : 03/30/2015
REVISION 2 : 05/30/2015
REVISION 3 : 11/08/2019

ITEM: 300350KE (B1-B3)



ASSEMBLY INSTRUCTIONS

ASSEMBLY TIPS:

1. Remove hardware from box and sort by size.
2. Please check to see that all hardware and parts are present prior to start of assembly.
3. Please follow attached instructions in the same sequence as numbered to assure fast & easy assembly.



WARNING!

1. Don't attempt to repair or modify parts that are broken or defective. Please contact the store immediately.
2. This product is for home use only and not intended for commercial establishments.



ASSEMBLY TIME

30 MINUTES

PARTS IDENTIFICATION

B1 (BOX 1)

AN HEADBOARD

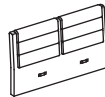

1PC

BN ROLL SLAT (14PCS)

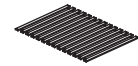

1SET

B2 (BOX 2)

CN FOOTBOARD PANEL

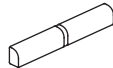

1PC

B3 (BOX 3)

DN LEFT SIDE RAIL



1PC

GN BED SLAT SUPPORT WITH LEVELER



6PCS

EN RIGHT SIDE RAIL



1PC

HN FOOTBOARD SUPPORT WITH LEVELER



1PC

FN FOOTBOARD LEG



2PCS

IN CENTER RAIL



2PCS

AN 300350KE (B1)
*FROM BOX 1
HEADBOARD



1PC

FBN 300350KE (B2 & B3)
*FROM BOX 2 & BOX 3
FOOTBOARD COMPLETE

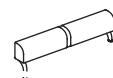

1PC

NOTE:

Phillips head screw driver is required in the assembly process; however, manufacturer does not provided this item.

ITEM: 300350KE (B1-B3)



ASSEMBLY TIPS:

1. Remove hardware from box and sort by size.
2. Please check to see that all hardware and parts are present prior to start of assembly.
3. Please follow attached instructions in the same sequence as numbered to assure fast & easy assembly.



WARNING!

1. Don't attempt to repair or modify parts that are broken or defective. Please contact the store immediately.
2. This product is for home use only and not intended for commercial establishments.

HARDWARE IDENTIFICATION

Z-B3 (BOX 3) - HARDWARE PACK IS LOCATED IN 300350KE (B3)

1 SHORT FLAT
HEAD SCREW
(M4 x 25MM - RBW)

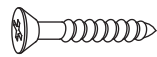

14PCS

2 LONG FLAT
HEAD SCREW
(M4 x 32MM - RBW)



34PCS

3 BOLT
(M6 x 35MM - RBW)

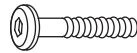

6PCS

4 SMALL ALLEN WRENCH
(M4 x 60MM - BLK)



1PC

5 BIG ALLEN WRENCH
(M5 x 65MM - BLK)



1PC

NOTE:

Phillips head screw driver is required in the assembly process; however, manufacturer does not provided this item.

ITEM: 300350KE (B1-B3)

ASSEMBLY INSTRUCTIONS

STEP 1

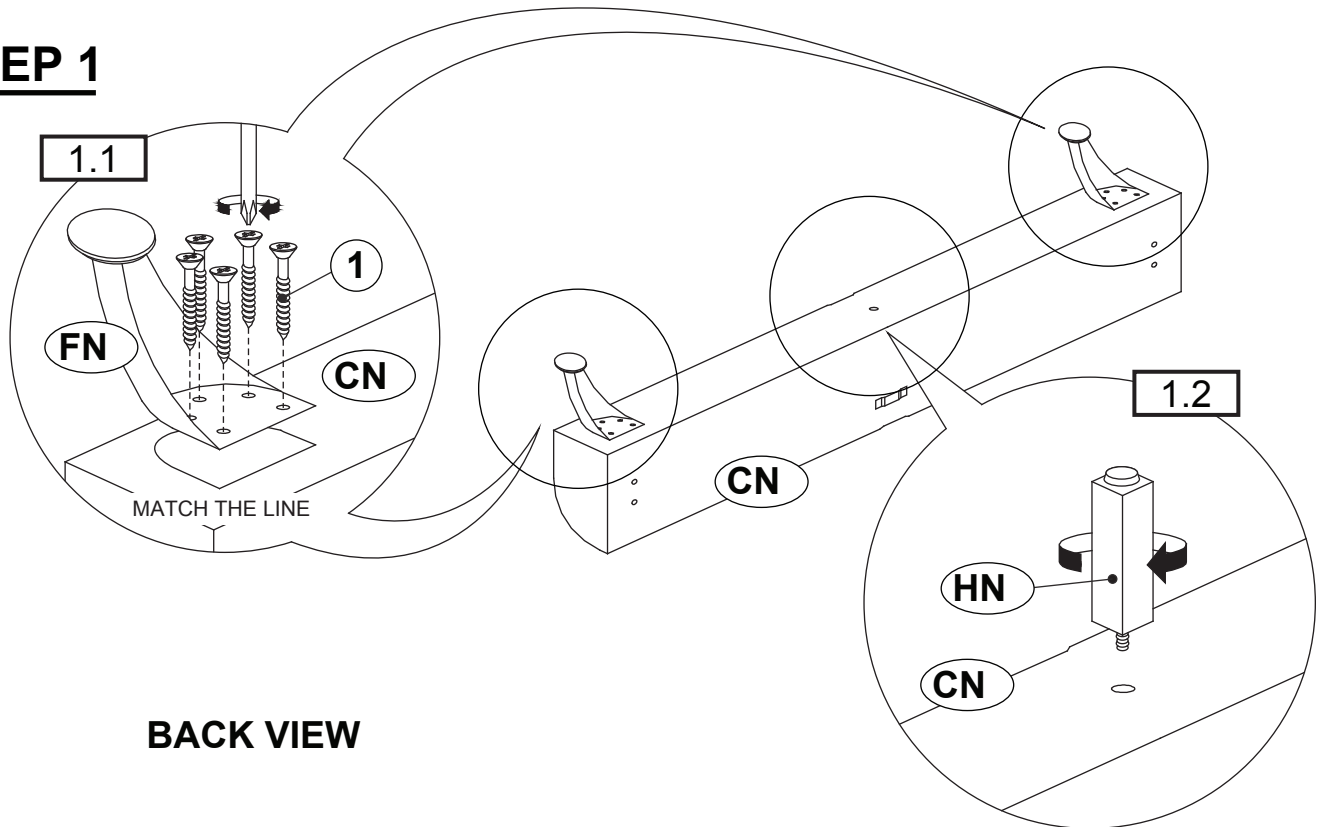

STEP 2

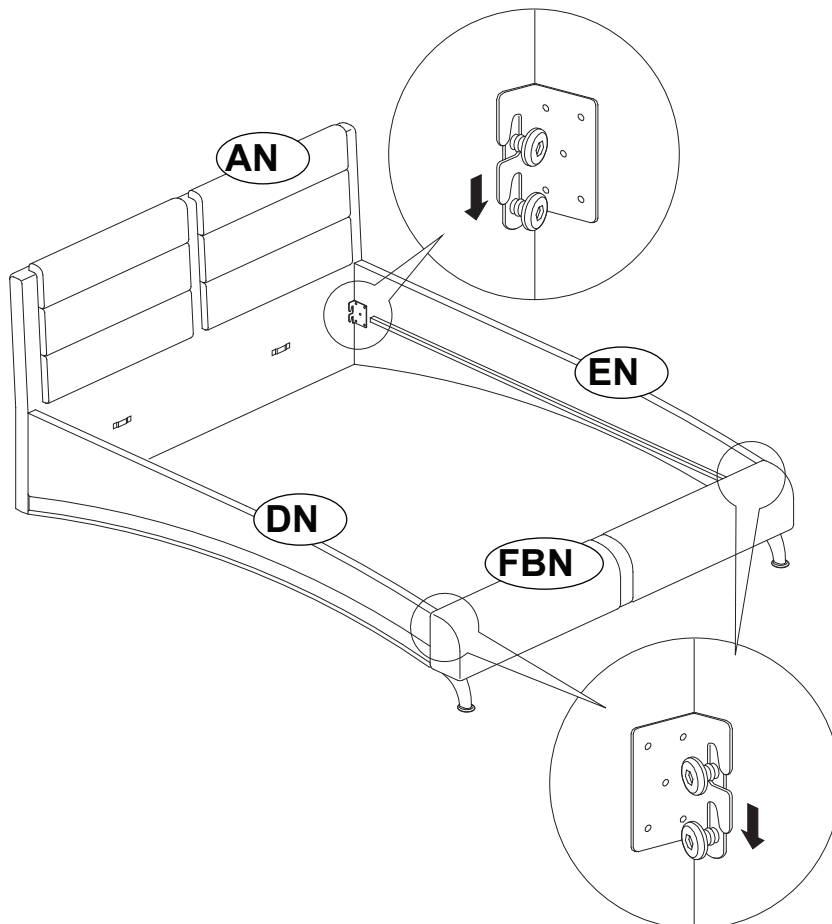

ITEM: 300350KE (B1-B3)

ASSEMBLY INSTRUCTIONS

STEP 3

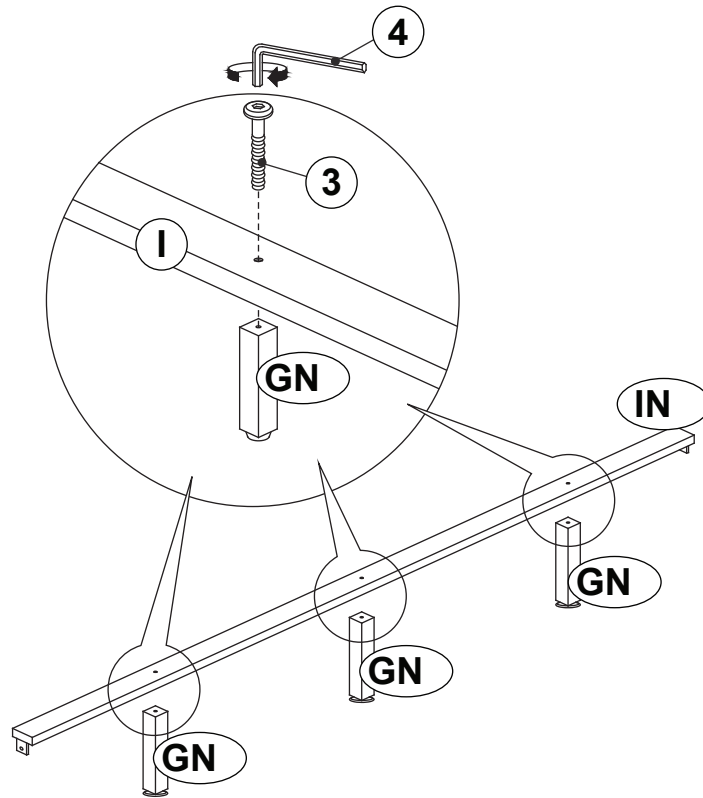

STEP 4

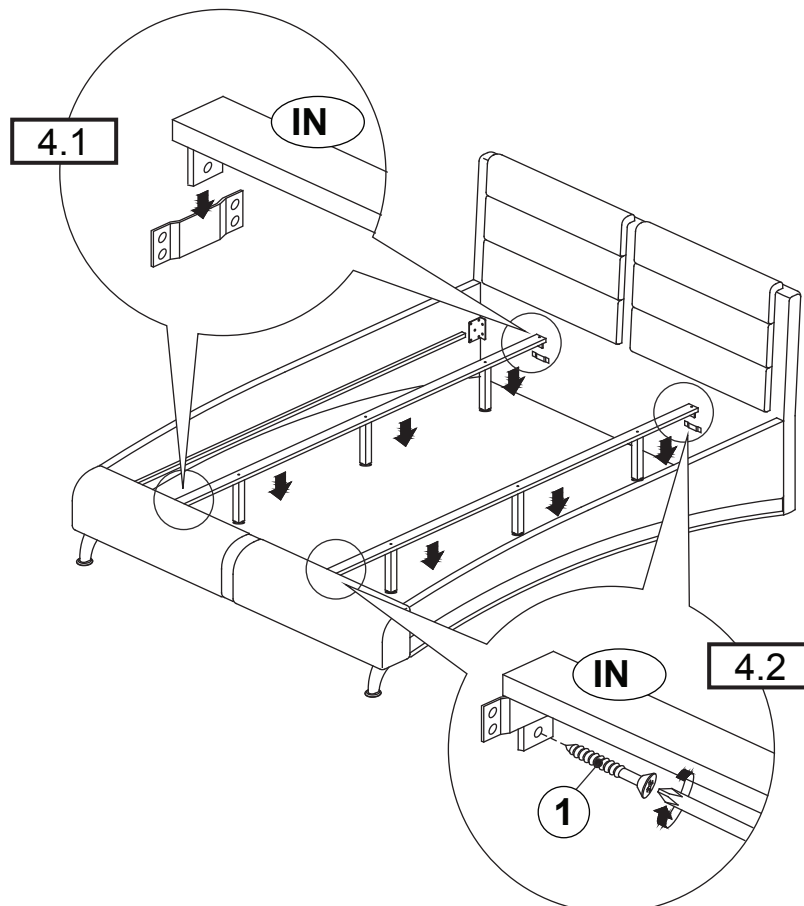

ITEM: **300350KE (B1-B3)**



ASSEMBLY INSTRUCTIONS

STEP 5

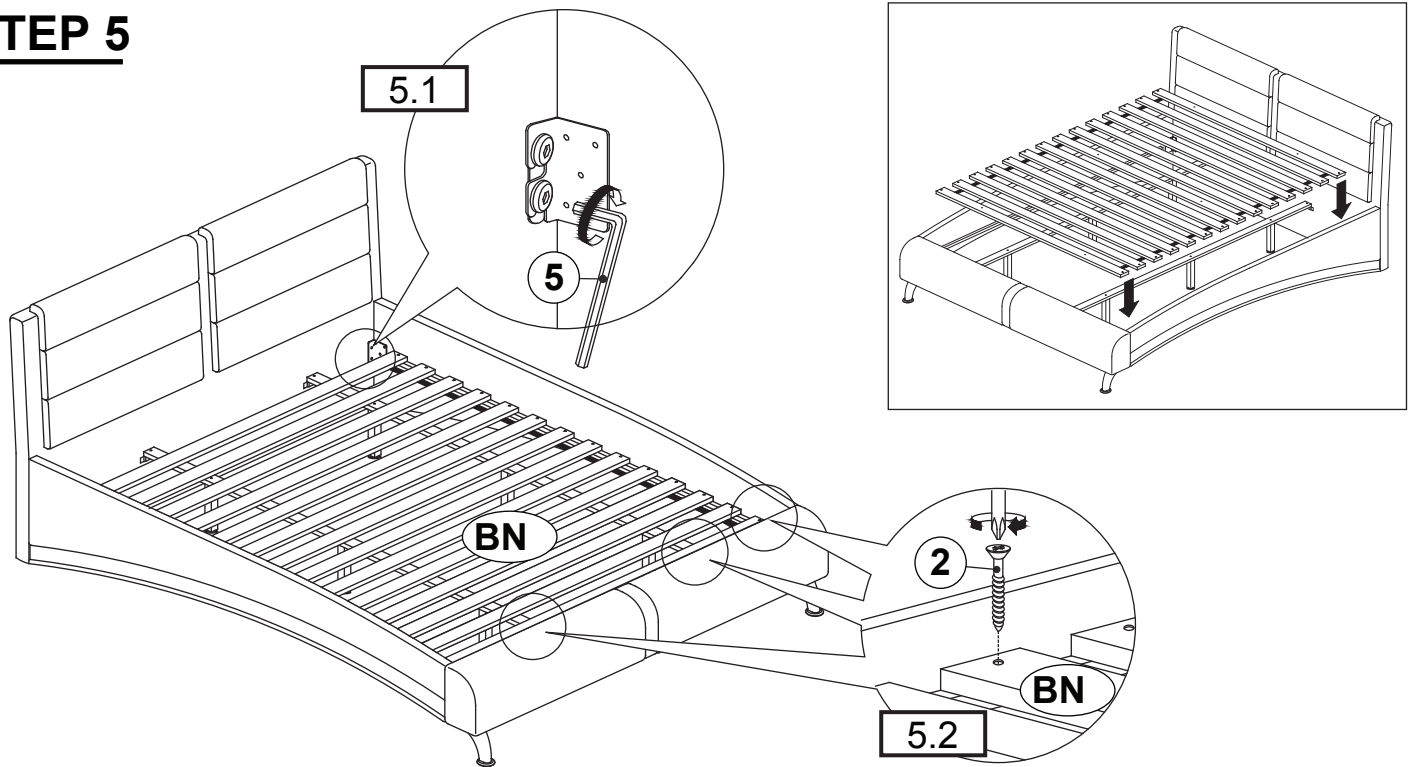

STEP 6

COMPLETE

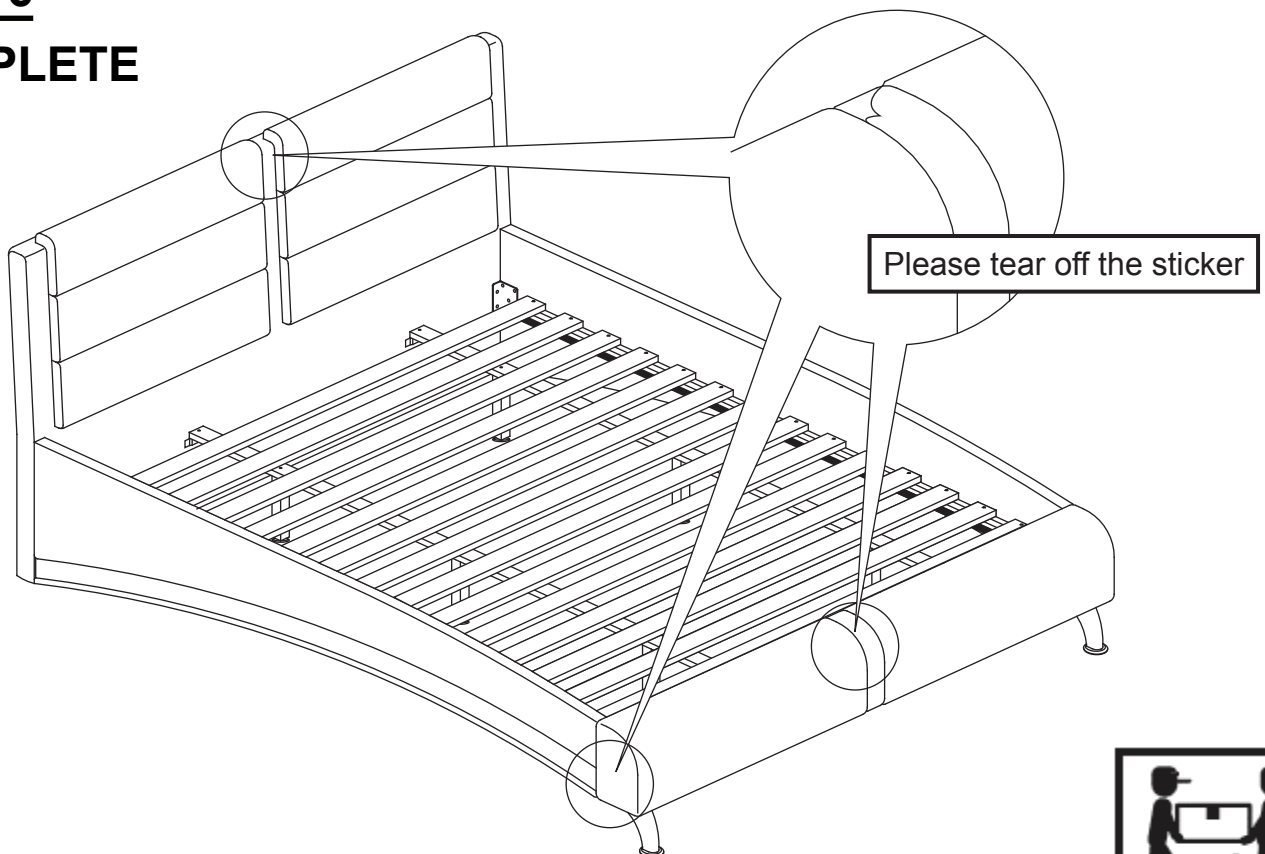

ITEM: **300350KE (B1-B3)**

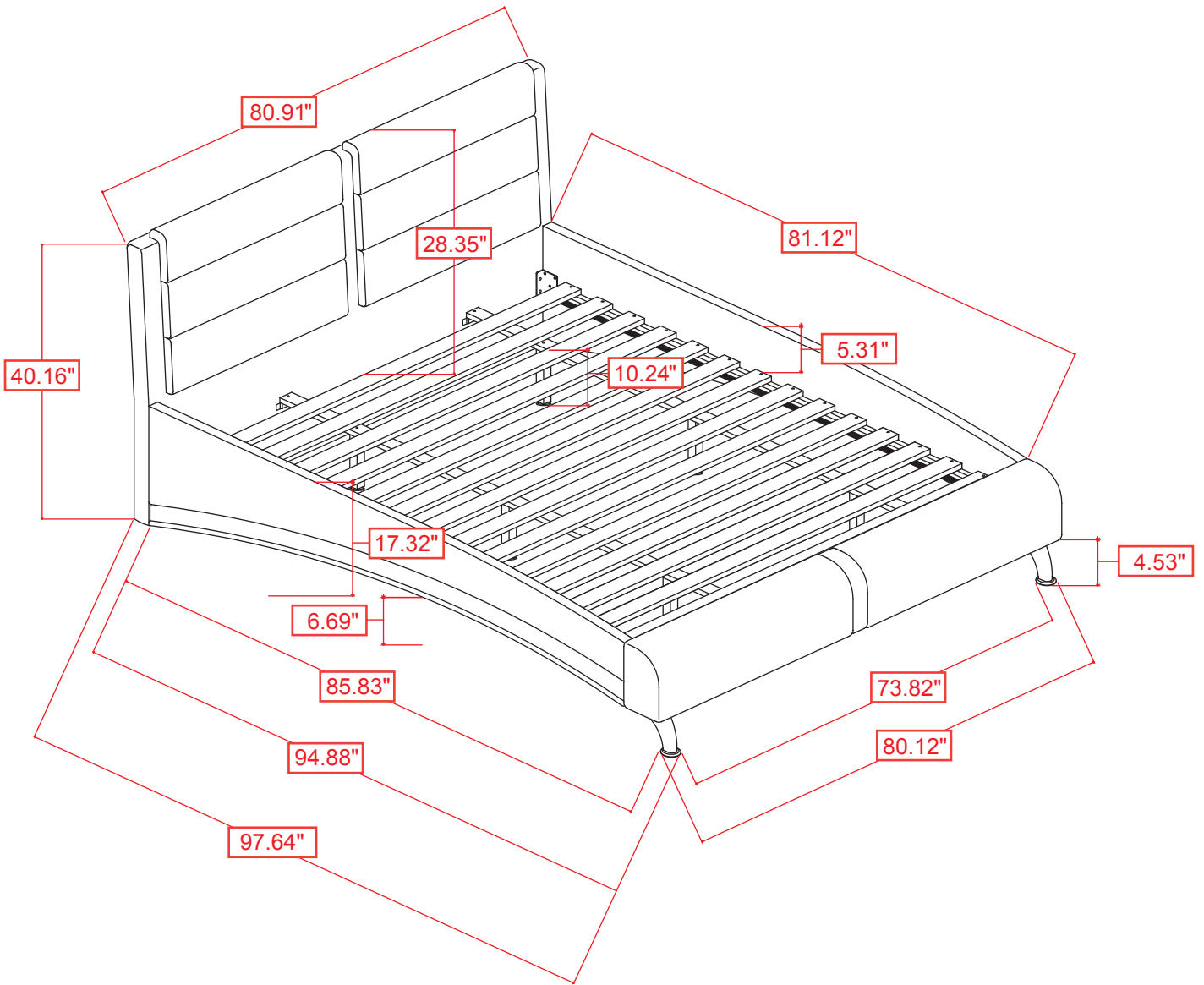

Note : Dimension tolerance $\pm 5\%$