

ASSEMBLY INSTRUCTIONS
COASTER FINE FURNITURE

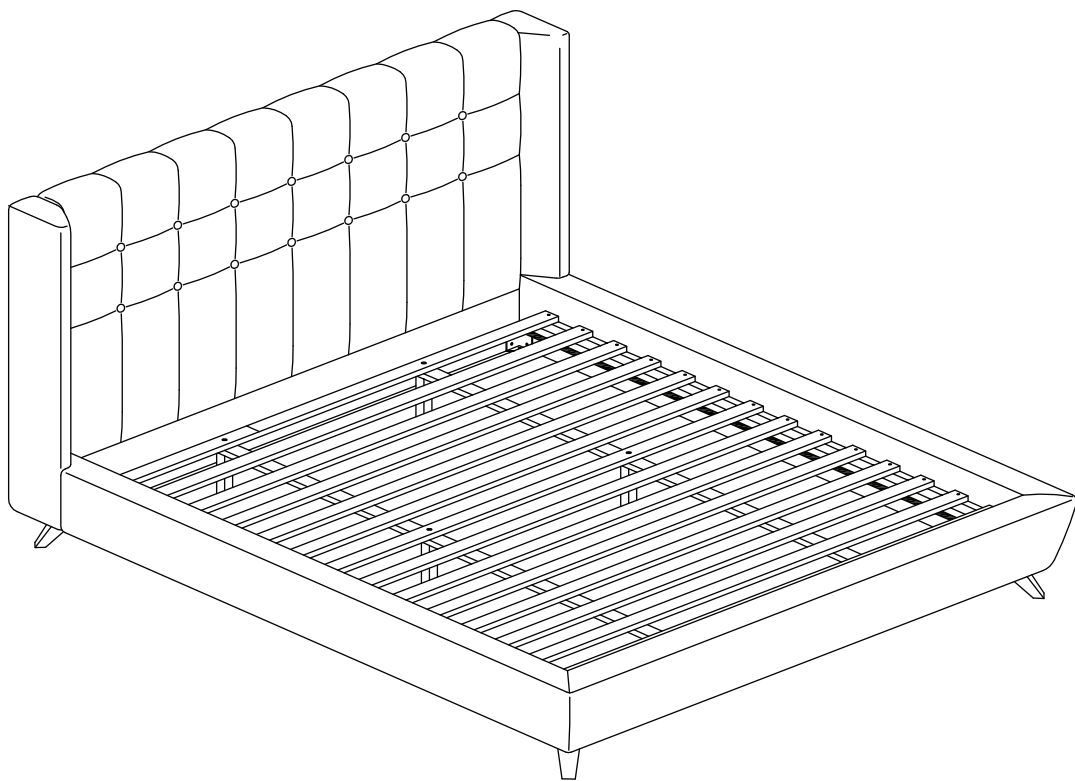

Fine Furniture for every stage of life

301061KW (B1&B2)
California King Bed

ITEM: 301061KW (B1&B2)



ASSEMBLY INSTRUCTIONS

ASSEMBLY TIPS:

1. Remove hardware from box and sort by size.
2. Please check to see that all hardware and parts are present prior to start of assembly.
3. Please follow attached instructions in the same sequence as numbered to assure fast & easy assembly.



WARNING!

1. Don't attempt to repair or modify parts that are broken or defective. Please contact the store immediately.
2. This product is for home use only and not intended for commercial establishments.



ASSEMBLY TIME

30 MINUTES

PARTS IDENTIFICATION

B1 (BOX 1)

A HEADBOARD

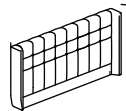

1PC

B ROLL SLAT
(13pcs)

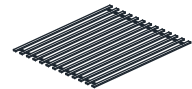

1SET

B2 (BOX 2)

C FOOTBOARD

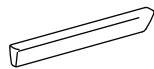

1PC

G RIGHT BED RAIL
(WITH "G" LABEL)



1PC

D BRACKET



4PCS

H CENTER RAIL



2PCS

E LEG



4PCS

I CENTER RAIL
SUPPORT
WITH LEVELER

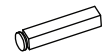

6PCS

F LEFT BED RAIL
(WITH "F" LABEL)



1PC

A 301061KW (B1)
FROM BOX 1
HEADBOARD

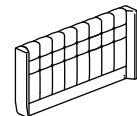

1SET

NOTE:

Phillips head screw driver is required in the assembly process; however, manufacturer does not provided this item.

ITEM: 301061KW (B1&B2)



ASSEMBLY INSTRUCTIONS

ASSEMBLY TIPS:

1. Remove hardware from box and sort by size.
2. Please check to see that all hardware and parts are present prior to start of assembly.
3. Please follow attached instructions in the same sequence as numbered to assure fast & easy assembly.







WARNING!

1. Don't attempt to repair or modify parts that are broken or defective. Please contact the store immediately.
2. This product is for home use only and not intended for commercial establishments.

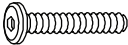
HARDWARE IDENTIFICATION

Z-B2 (BOX 2) - HARDWARE PACK IS LOCATED IN 301061KW (B2)

1	SHORT BOLT (M8 x 30MM - RBW)		20PCS
2	LONG BOLT (M6 x 50MM - RBW)		6PCS
3	FLAT HEAD SCREW (M4 x 32MM - RBW)		26PCS
4	SMALL ALLEN WRENCH (M4 x 100MM - BLK)		1PC
5	BIG ALLEN WRENCH (M5 x 65MM - BLK)		1PC

NOTE:

Phillips head screw driver is required in the assembly process; however, manufacturer does not provided this item.

ITEM: 301061KW (B1&B2)

ASSEMBLY INSTRUCTIONS

STEP 1

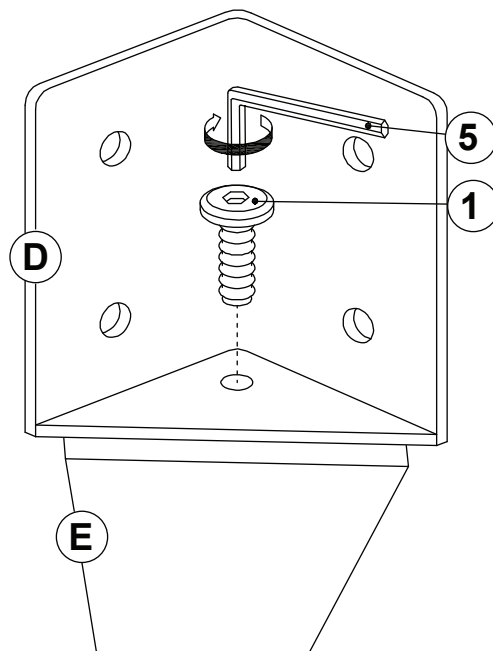

STEP 2

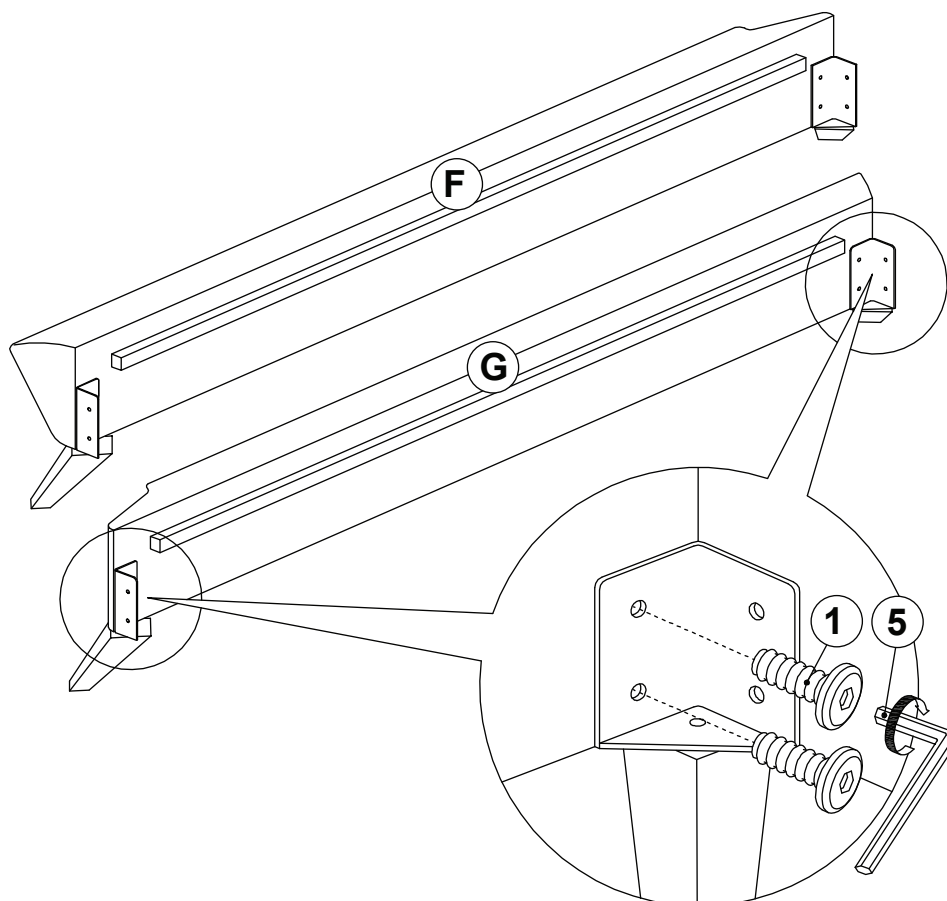

ITEM: **301061KW (B1&B2)**

ASSEMBLY INSTRUCTIONS

STEP 3

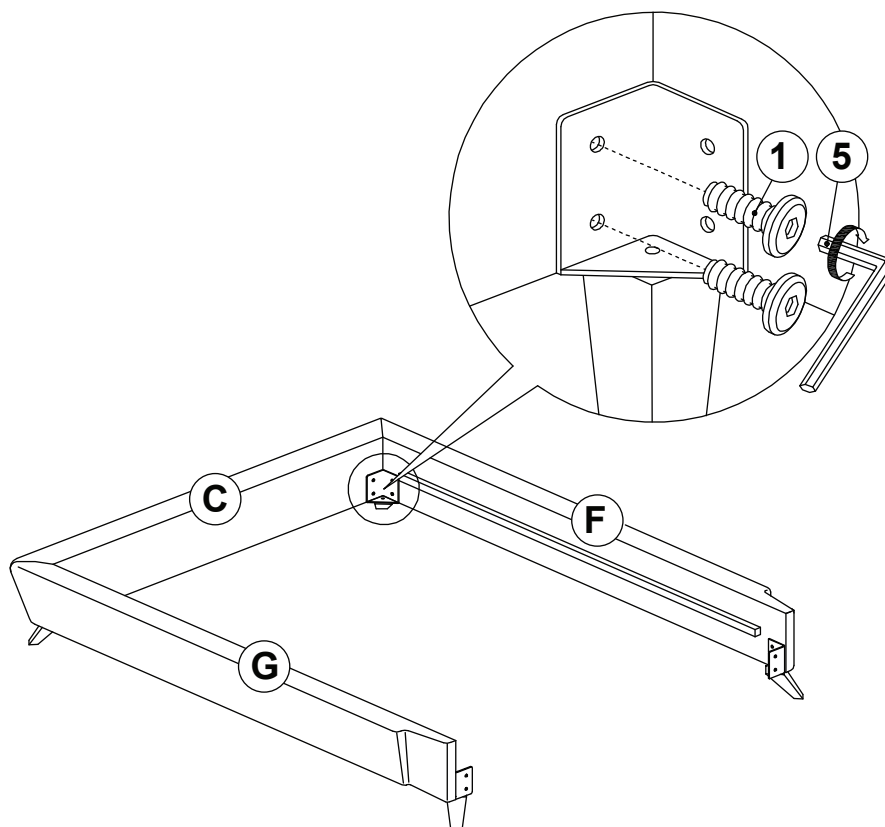

STEP 4

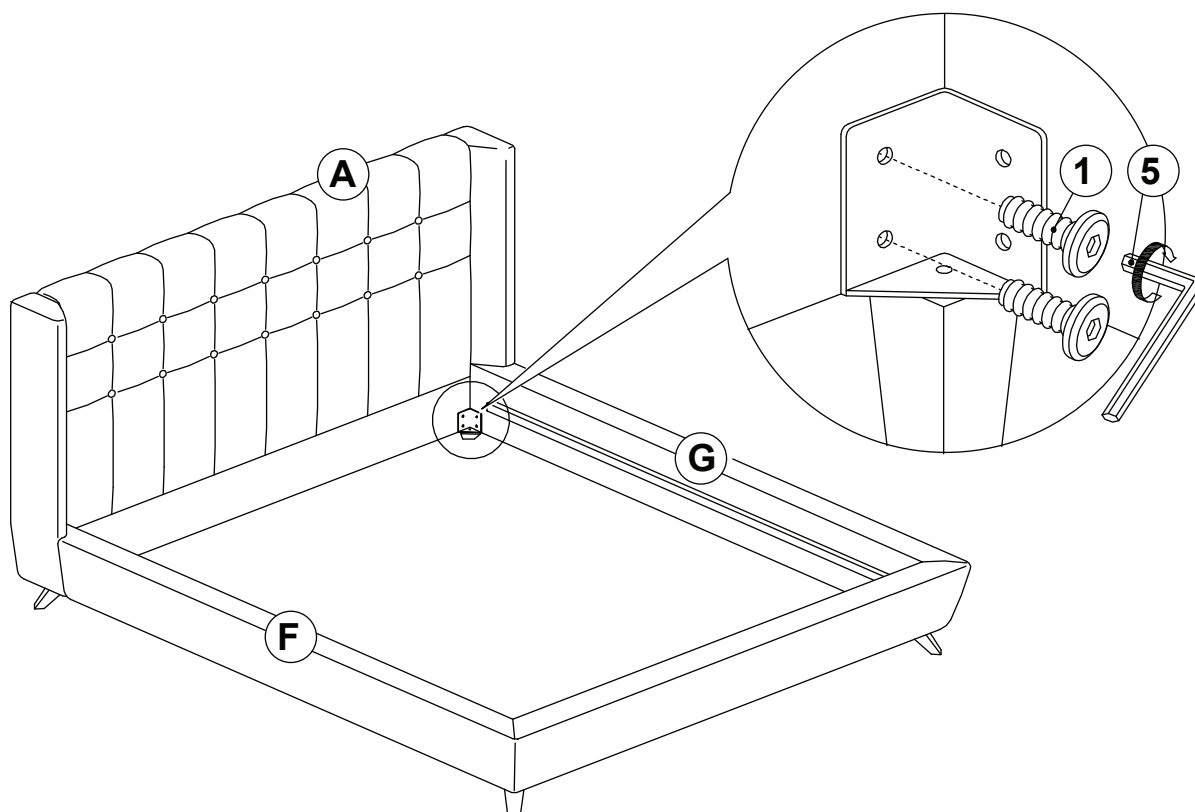

ITEM: 301061KW (B1&B2)

ASSEMBLY INSTRUCTIONS

STEP 5

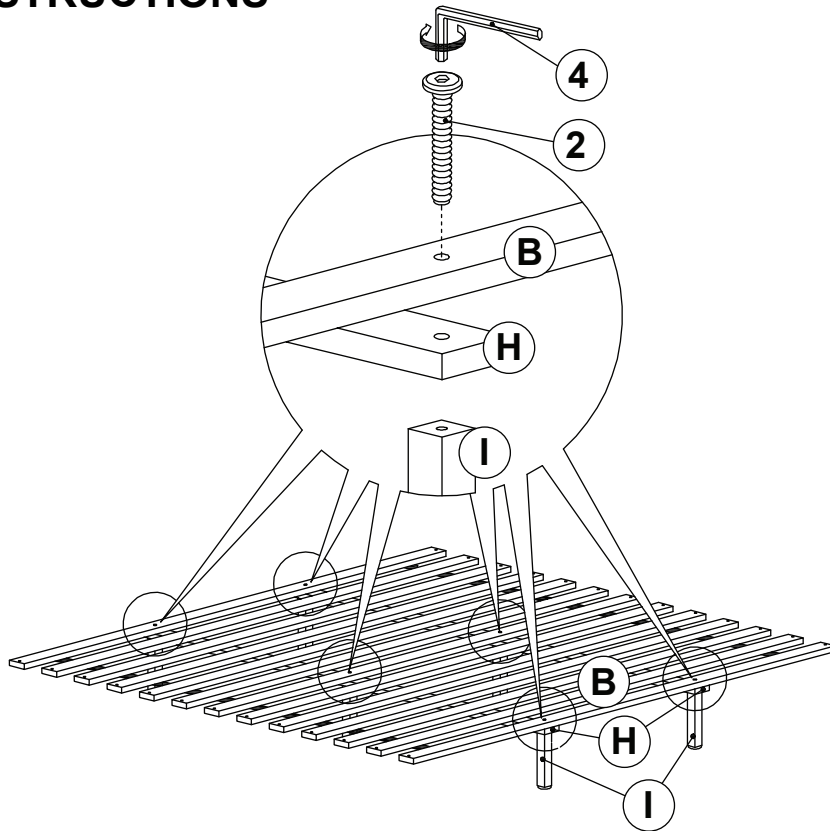

STEP 6

COMPLETE

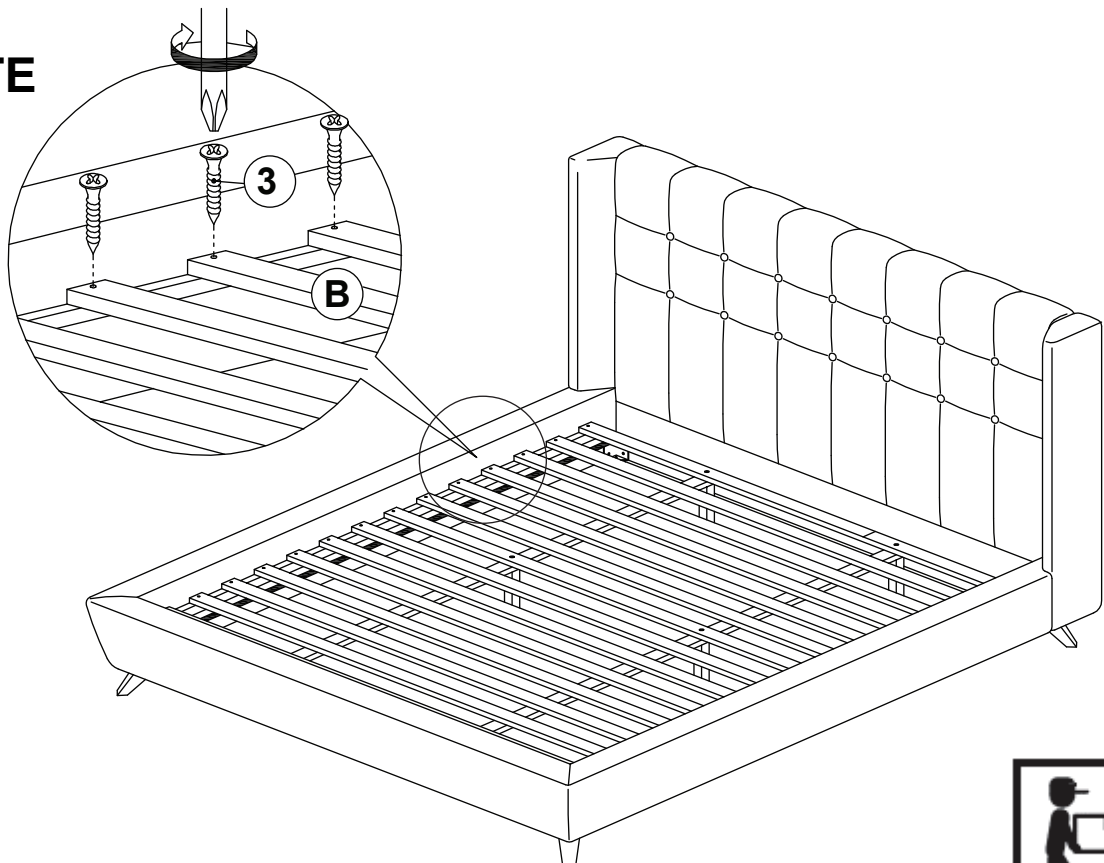

ITEM: **301061KW (B1&B2)**

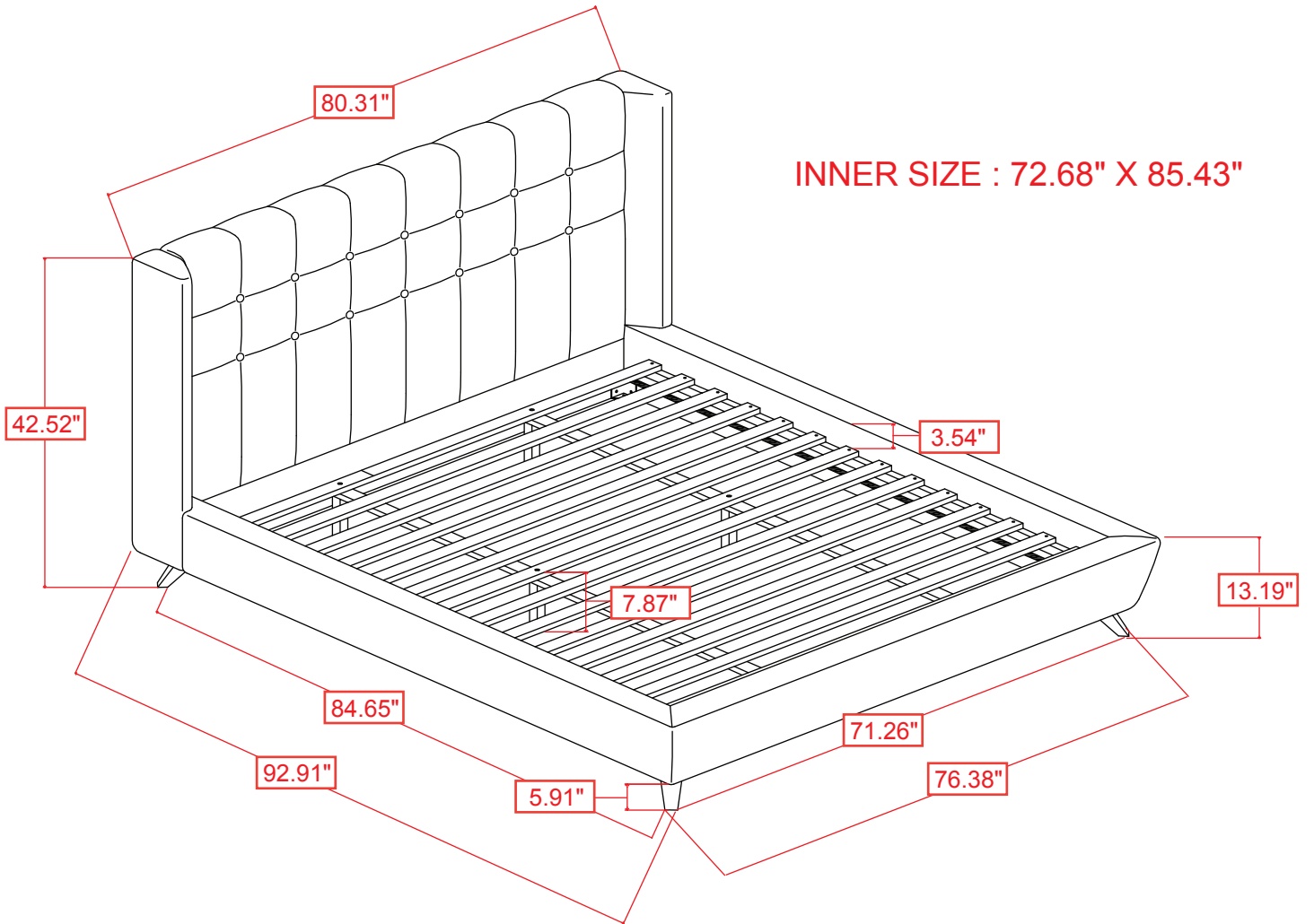

Note : Dimension tolerance $\pm 5\%$