

ASSEMBLY INSTRUCTIONS
COASTER FINE FURNITURE

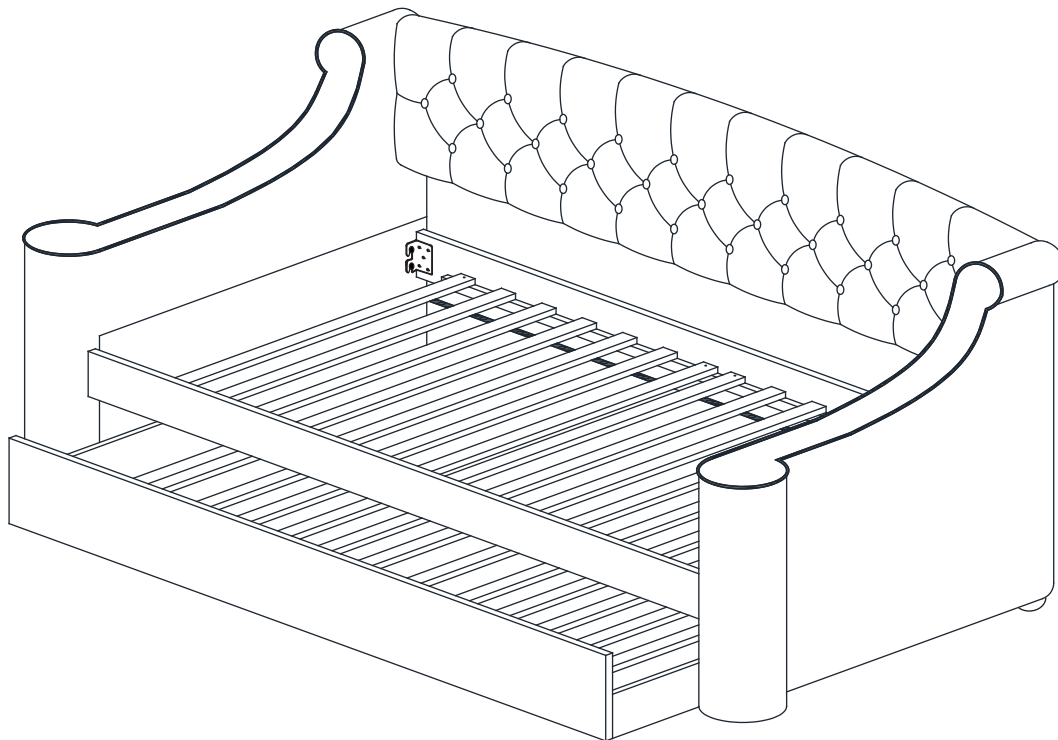

Fine Furniture for every stage of life

305911 (B1&B2)
Daybed

ITEM: 305911 (B1&B2)



ASSEMBLY INSTRUCTIONS

ASSEMBLY TIPS:

1. Remove hardware from box and sort by size.
2. Please check to see that all hardware and parts are present prior to start of assembly.
3. Please follow attached instructions in the same sequence as numbered to assure fast & easy assembly.



WARNING!

1. Don't attempt to repair or modify parts that are broken or defective. Please contact the store immediately.
2. This product is for home use only and not intended for commercial establishments.







ASSEMBLY TIME





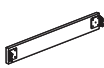

35 MINUTES

PARTS IDENTIFICATION

B1 (BOX 1)

<p>A LEFT SIDE PANEL</p>  <p>1PC</p>	<p>D ROLL SALT (7PCS)</p>  <p>2SETS</p>
<p>B RIGHT SIDE PANEL</p>  <p>1PC</p>	<p>E TRUNDLE SIDE PANEL</p>  <p>2PCS</p>
<p>C BUN FOOT</p>  <p>4PCS</p>	<p>F TRUNDLE ROLL SLAT (5PCS)</p>  <p>2SETS</p>

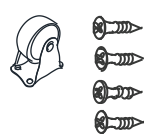
B2 (BOX 2)

<p>G BACK PANEL</p>  <p>1PC</p>	<p>K TRUNDLE BACK PANEL</p>  <p>1PC</p>
<p>H FRONT RAIL</p>  <p>1PC</p>	<p>L TRUNDLE SLAT</p>  <p>3PCS</p>
<p>I BACK RAIL</p>  <p>1PC</p>	<p>M CASTER WITH SCREW</p>  <p>6SETS</p>
<p>J TRUNDLE FRONT PANEL</p>  <p>1PC</p>	

NOTE:

Phillips head screw driver is required in the assembly process; however, manufacturer does not provided this item.

ITEM: 305911 (B1&B2)



ASSEMBLY TIPS:

1. Remove hardware from box and sort by size.
2. Please check to see that all hardware and parts are present prior to start of assembly.
3. Please follow attached instructions in the same sequence as numbered to assure fast & easy assembly.









WARNING!

1. Don't attempt to repair or modify parts that are broken or defective. Please contact the store immediately.
2. This product is for home use only and not intended for commercial establishments.

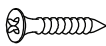
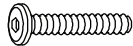
HARDWARE IDENTIFICATION

Z-B2 (BOX 2) - HARDWARE PACK IS LOCATED IN 305911 (B2)

1	SHORT BOLT (M8 x 20MM - RBW)		16PCS	6	SMALL FLAT WASHER (15/64" X 13 Ø - RBW)		12PCS
2	MEDIUM BOLT (M6 x 40MM - RBW)		4PCS	7	FLAT HEAD SCREW (M4 x 32MM - RBW)		16PCS
3	LONG BOLT (M6 x 50MM - RBW)		16PCS	8	SMALL ALLEN WRENCH (M4 x 100MM - BLK)		1PC
4	LOCK WASHER (15/64" x 13 Ø - RBW)		16PCS	9	BIG ALLEN WRENCH (M5 x 65MM - BLK)		1PC
5	BIG FLAT WASHER (15/64" x 19 Ø - RBW)		4PCS				

NOTE:

Phillips head screw driver is required in the assembly process; however, manufacturer does not provided this item.

ITEM: **305911 (B1&B2)**

ASSEMBLY INSTRUCTIONS

STEP 1

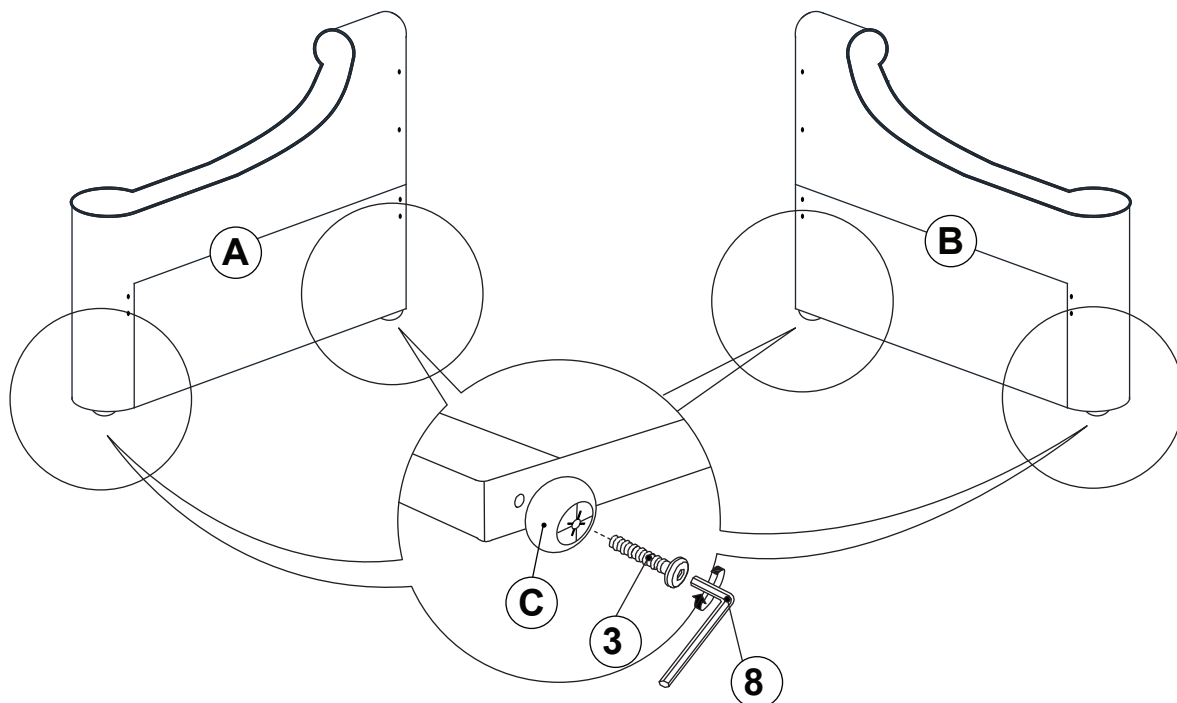

STEP 2

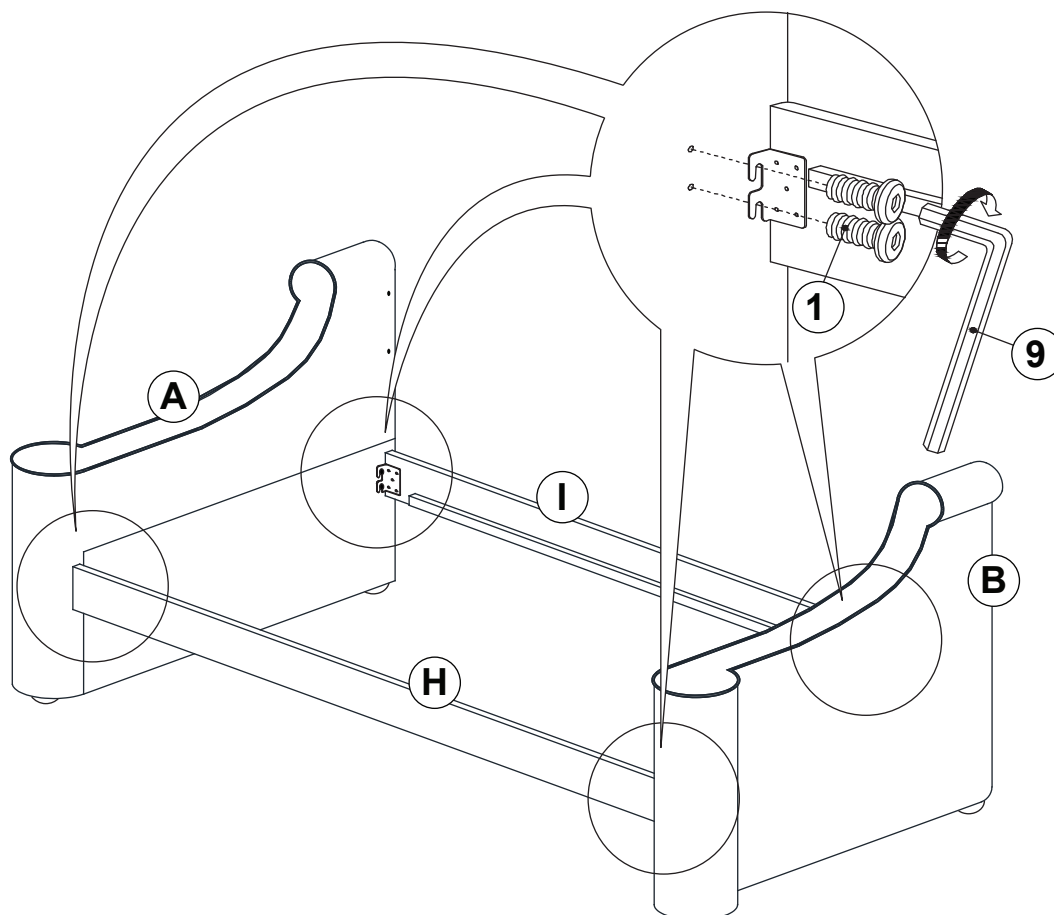

ITEM: **305911 (B1&B2)**

ASSEMBLY INSTRUCTIONS

STEP 3

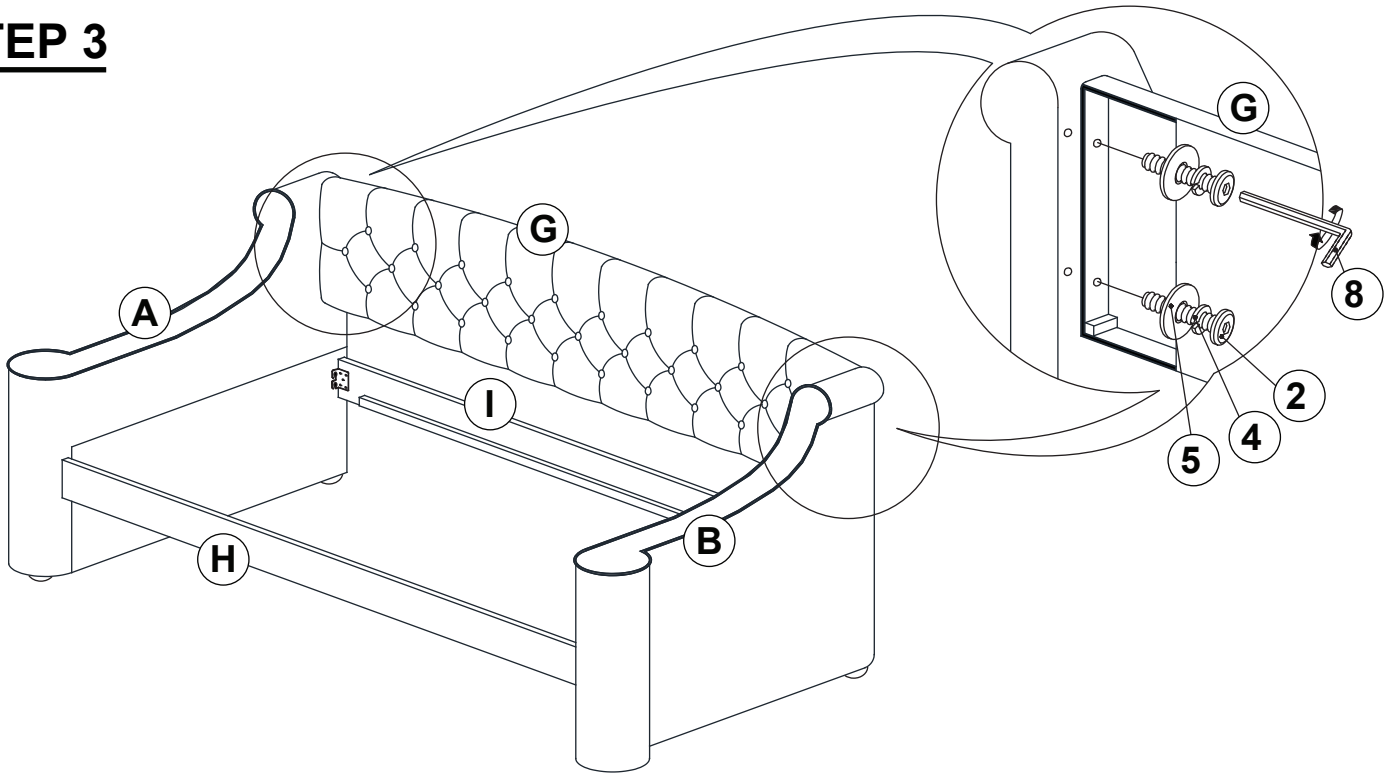

STEP 4

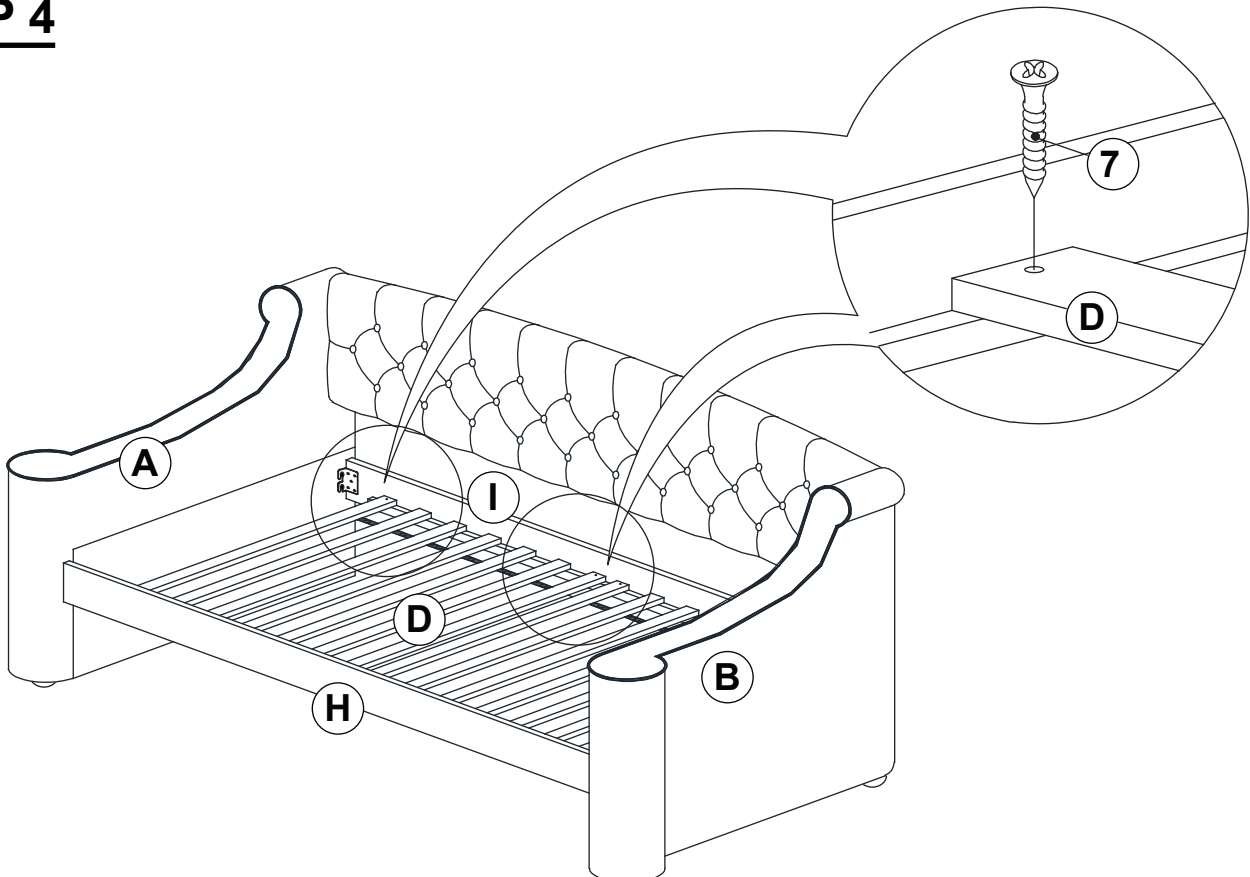

ITEM: **305911 (B1&B2)**

ASSEMBLY INSTRUCTIONS

STEP 5

cover the fabric lining behind the back panel.

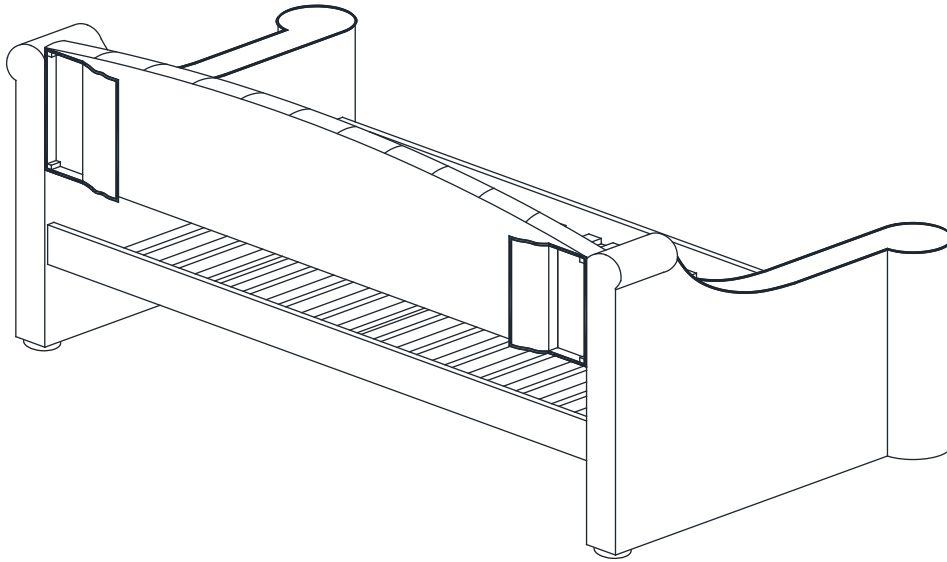

STEP 6

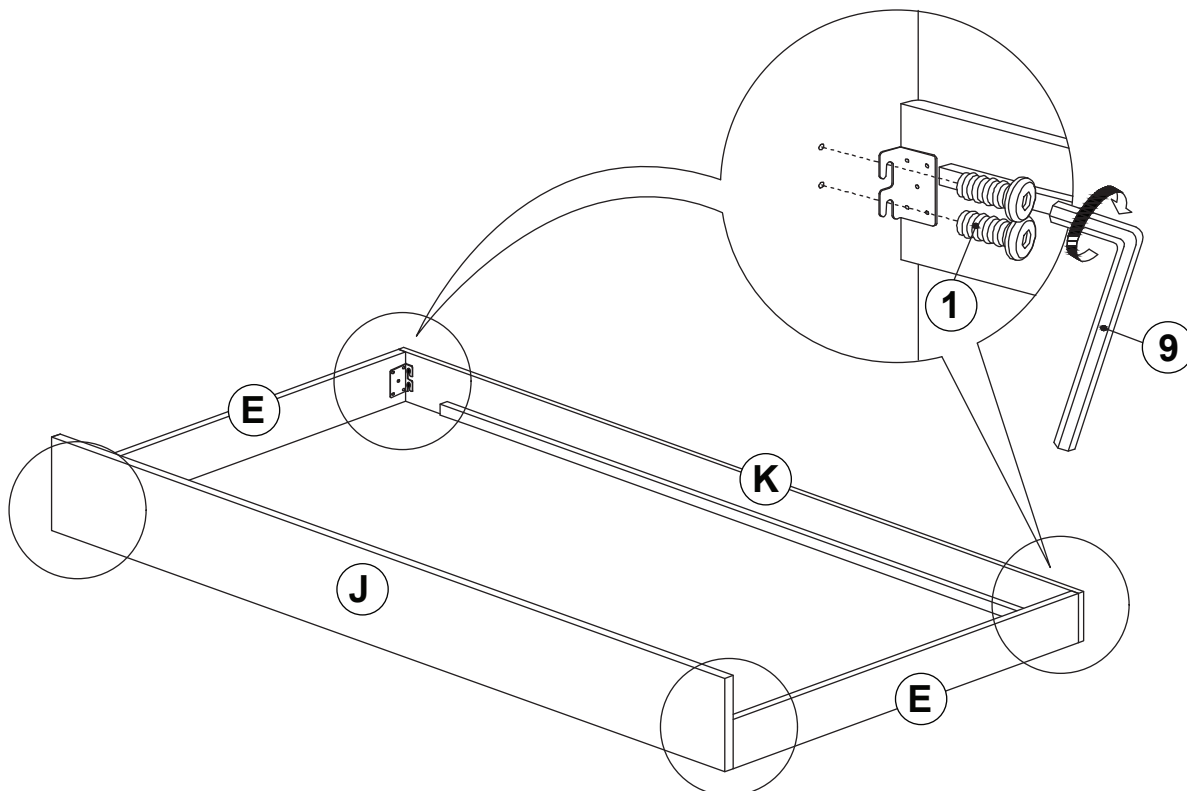

ITEM: 305911 (B1&B2)

ASSEMBLY INSTRUCTIONS

STEP 7

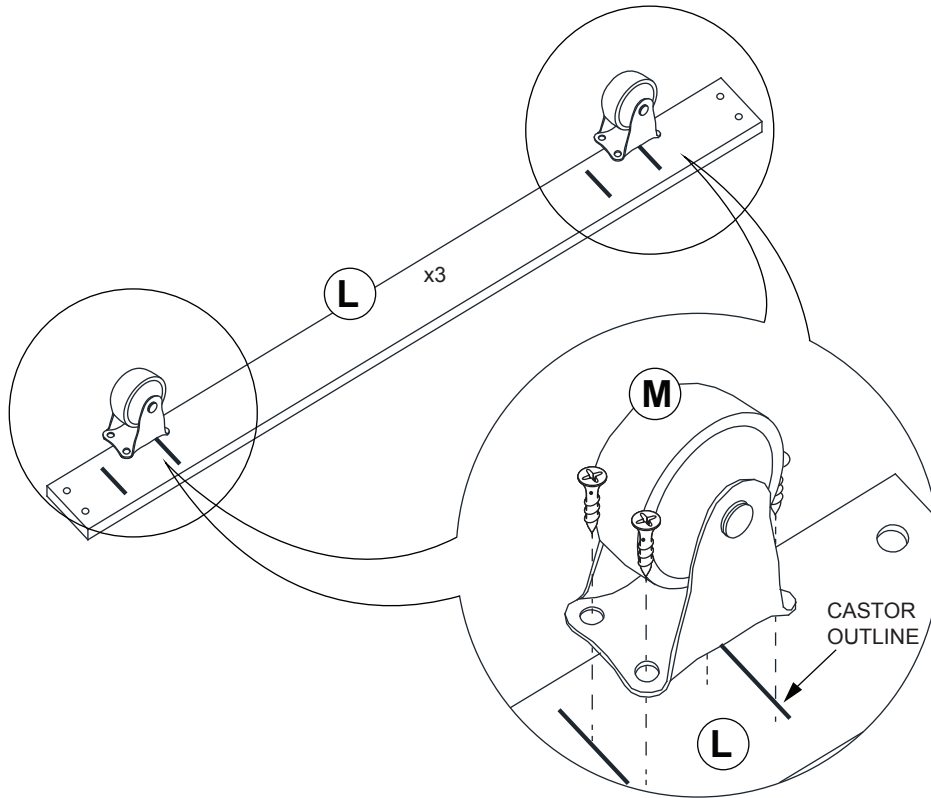

STEP 8

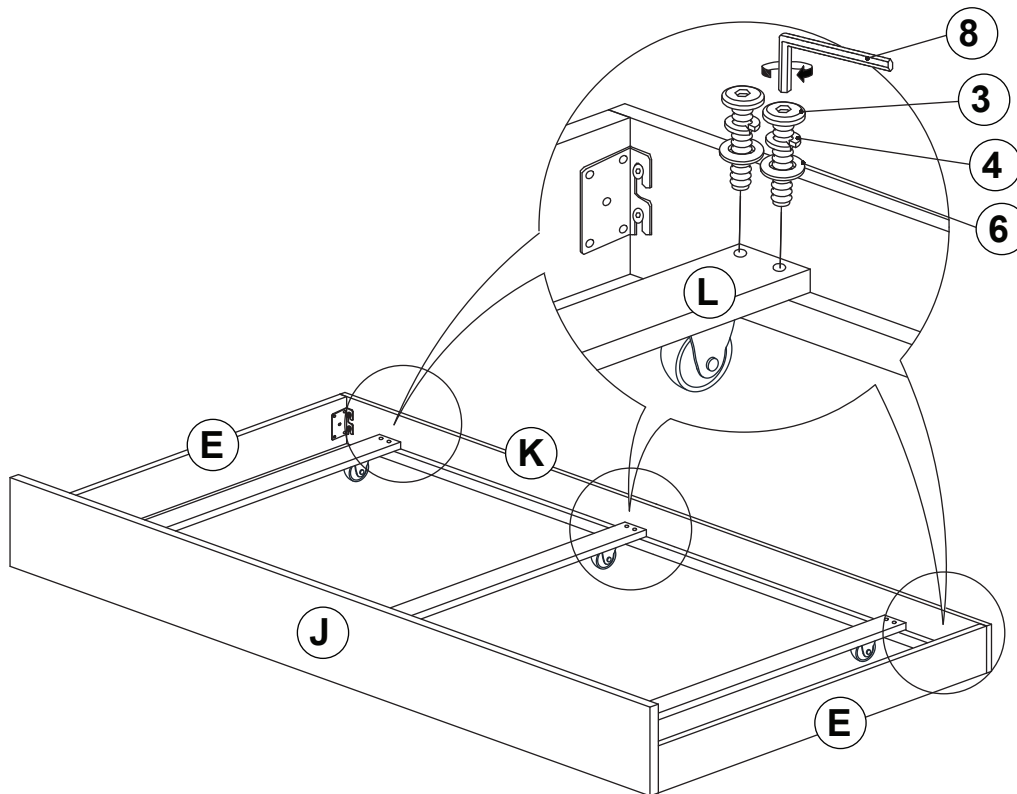

ITEM: **305911 (B1&B2)**

ASSEMBLY INSTRUCTIONS

STEP 9

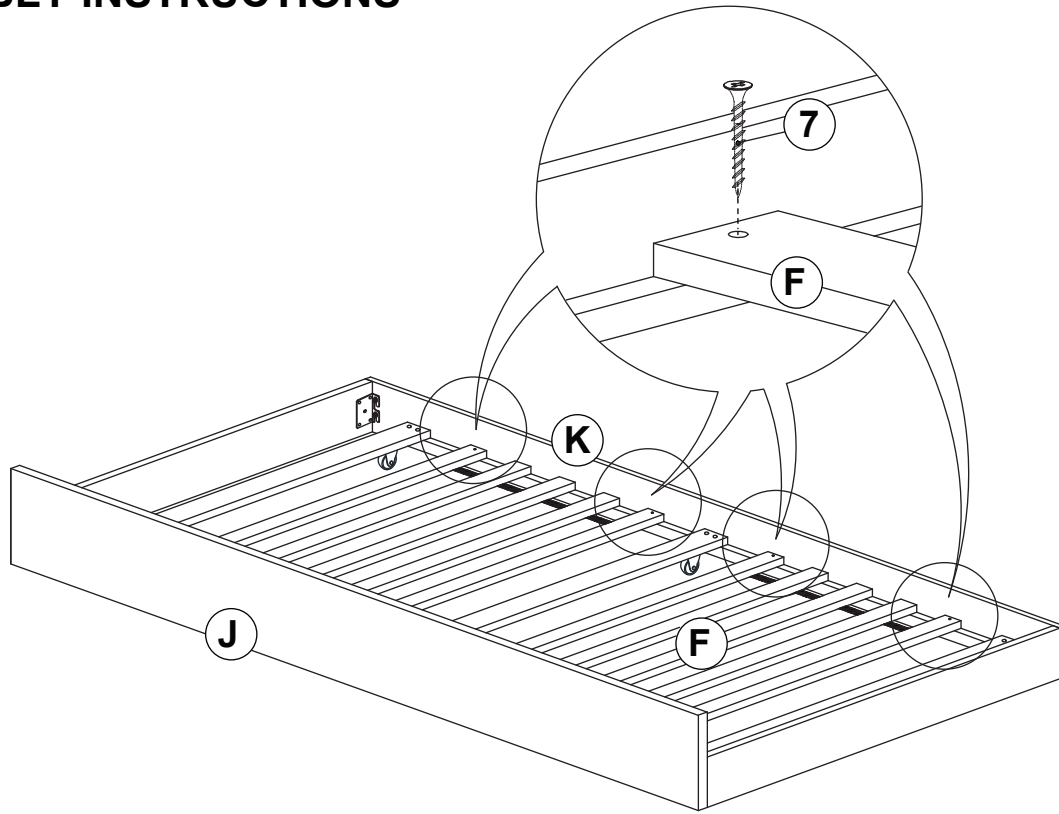

STEP 10
COMPLETE

