

ASSEMBLY INSTRUCTIONS
COASTER FINE FURNITURE

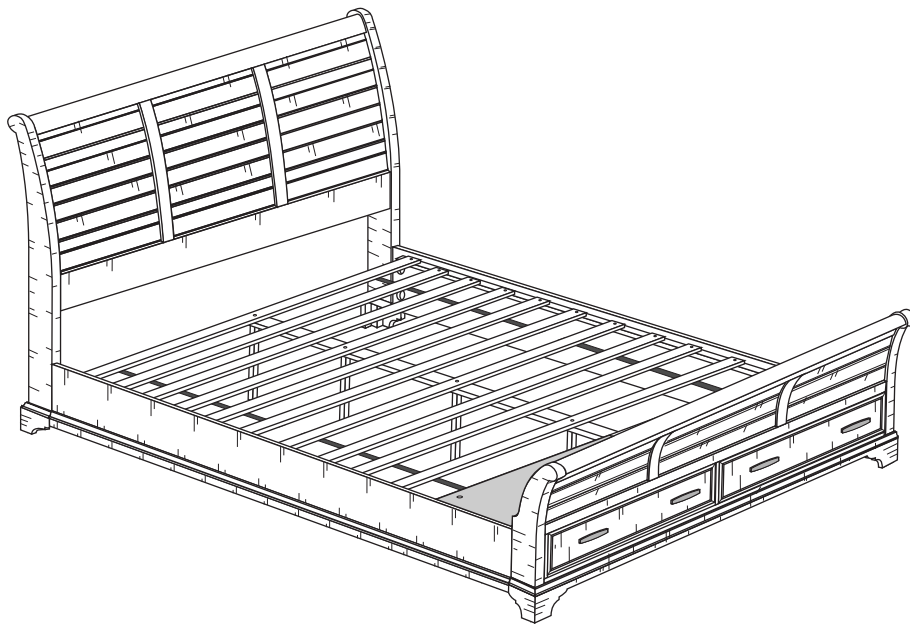

Fine Furniture for every stage of life

203891Q (B1-B3)
Queen Storage Bed

REVISION 0:12/30/2014
REVISION 1:03/19/2015
REVISION 2:10/16/2017
REVISION 3:08/23/2018
REVISION 4:01/03/2020

COASTERFURNITURE.COM

ITEM: 203891Q (B1 - B3)



ASSEMBLY INSTRUCTIONS

ASSEMBLY TIPS:

- 1 . Remove hardware from box and sort by size.
- 2 . Please check to see that all hardware and parts are present prior to start of assembly.
- 3 . Please follow attached instructions in the same sequence as numbered to assure fast & easy assembly.



WARNING!

- 1 . Don't attempt to repair or modify parts that are broken or defective. Please contact the store immediately.
- 2 . This product is for home use only and not intended for commercial establishments.

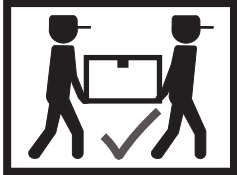

ASSEMBLY TIME

20 MINUTES

PARTS IDENTIFICATION

B1 (BOX 1)

A HEADBOARD

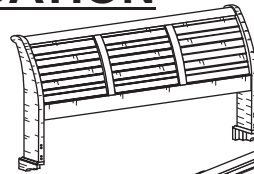

1PC

B2 (BOX 2)

B STORAGE FOOTBOARD

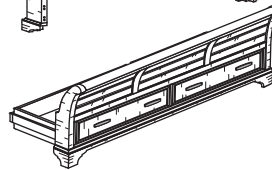

1PC

H FOOTBOARD SUPPORT LEG WITH LEVELER



2PCS

B3 (BOX 3)

C BED RAIL



2PCS

D ROLL SLAT (6PCS)



2SETS

E CENTER RAIL



1PC

F CENTER RAIL SUPPORT WITH LEVELER



4PCS

G SHORT CENTER RAIL SUPPORT



1PC

I CONCEAL PANEL



2PCS

A 203891Q (B1)
FROM BOX 1
HEADBOARD

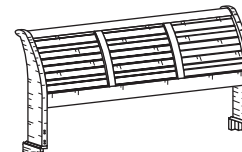

1PC

FB 203891Q (B2)
FROM BOX 2
STORAGE FOOTBOARD
COMPLETE

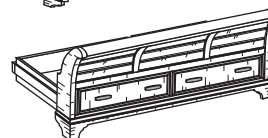

1PC

ITEM: 203891Q (B1 - B3)



ASSEMBLY INSTRUCTIONS

ASSEMBLY TIPS:

- 1 . Remove hardware from box and sort by size.
- 2 . Please check to see that all hardware and parts are present prior to start of assembly.
- 3 . Please follow attached instructions in the same sequence as numbered to assure fast & easy assembly.















WARNING!

- 1 . Don't attempt to repair or modify parts that are broken or defective. Please contact the store immediately.
- 2 . This product is for home use only and not intended for commercial establishments.

HARDWARE IDENTIFICATION

Z-B3 (BOX 3) - HARDWARE PACK IS LOCATED IN 203891Q (B3)

1	THREADED BOLT (M6 x 13mm - RBW)		8PCS
2	WOOD DOWEL (Ø 10 x 30mm)		8PCS
3	HALF ROUND NUT (7 x 15mm- BLK)		8PCS
4	SMALL FLAT WASHER (M6 x 13mm - RBW)		8PCS
5	HEX NUT (M6 x 10mm - RBW)		8PCS
6	WRENCH (10 x 85mm - RBW)		1PC
7	LONG FLAT HEAD SCREW (M4 x 30mm - RBW)		24PCS
8	SHORT FLAT HEAD SCREW (M4 x 16mm - RBW)		8PCS
9	LONG BOLT (M6 x 60mm - RBW)		4PCS
10	SHORT BOLT (M6 x 40mm - RBW)		2PCS
11	ALLEN WRENCH (M4 x 58mm- BLK)		1PC
12	BIG FLAT WASHER (M6 x 19mm - RBW)		2PCS
13	LOCK WASHER (M6 x 13mm - RBW)		2PCS

NOTE :

Phillips head screw driver is required in the assembly process; however, manufacturer does not provide this item.

ITEM: 203891Q (B1 - B3)

ASSEMBLY INSTRUCTIONS



STEP 1

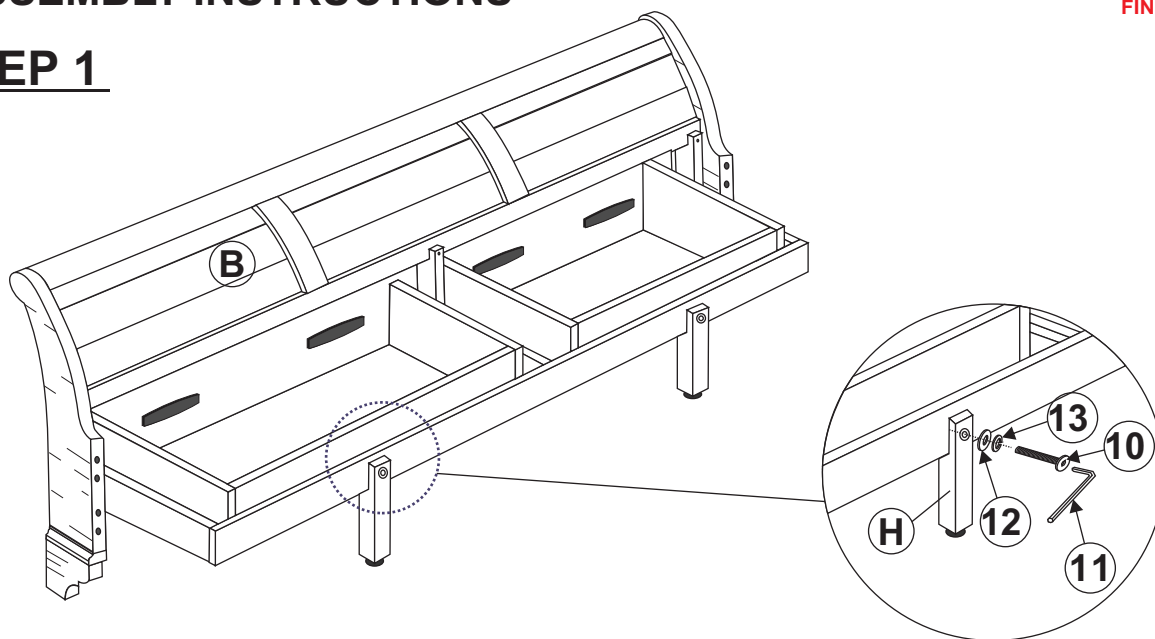

STEP 2

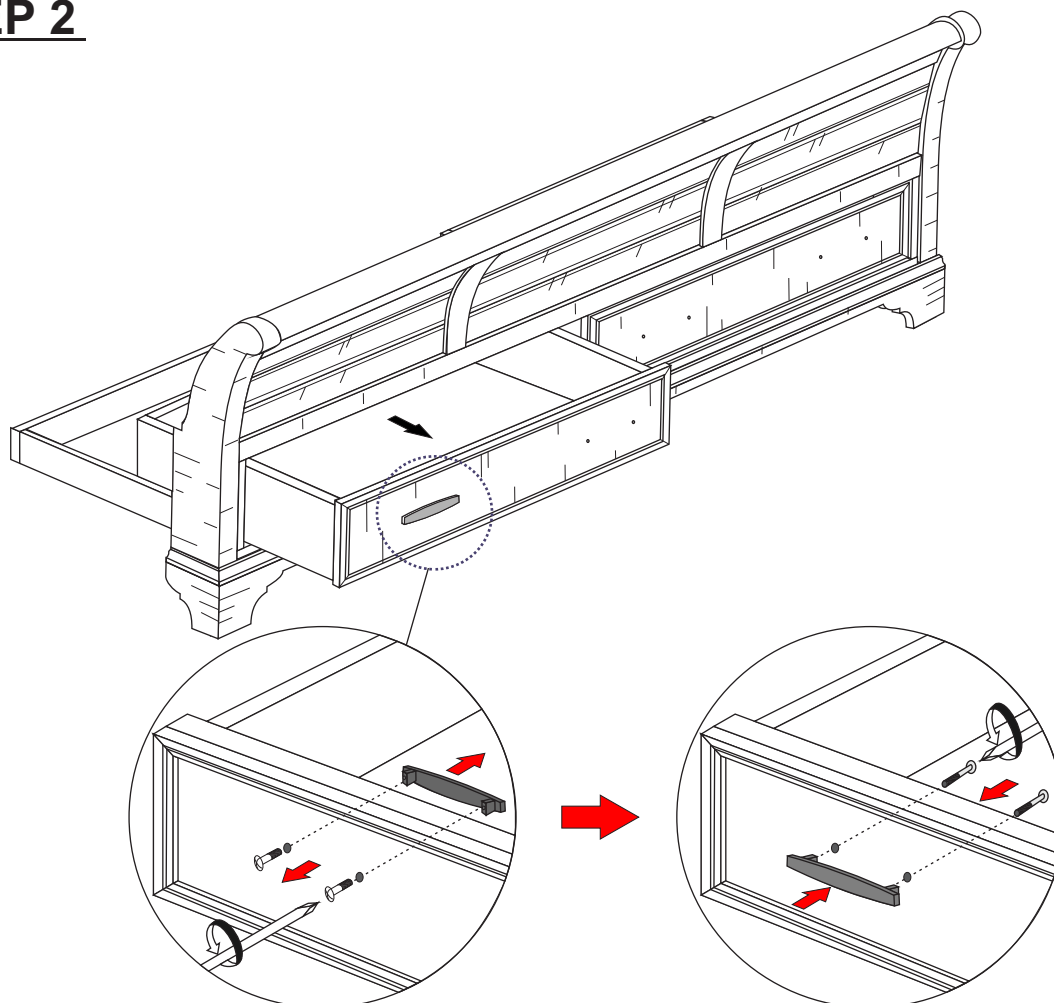

ITEM: 203891Q (B1 - B3)

ASSEMBLY INSTRUCTIONS



STEP 3

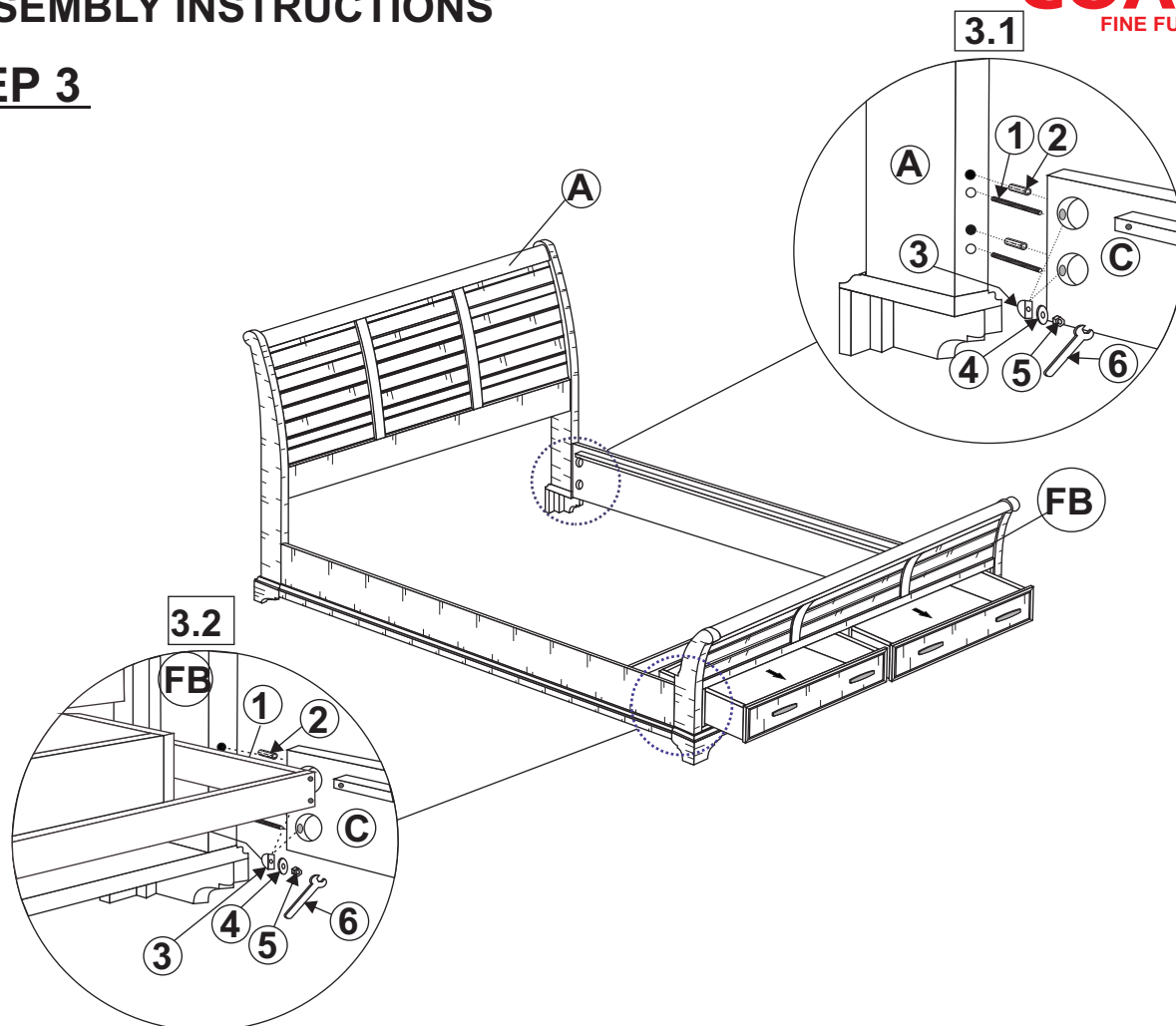

STEP 4

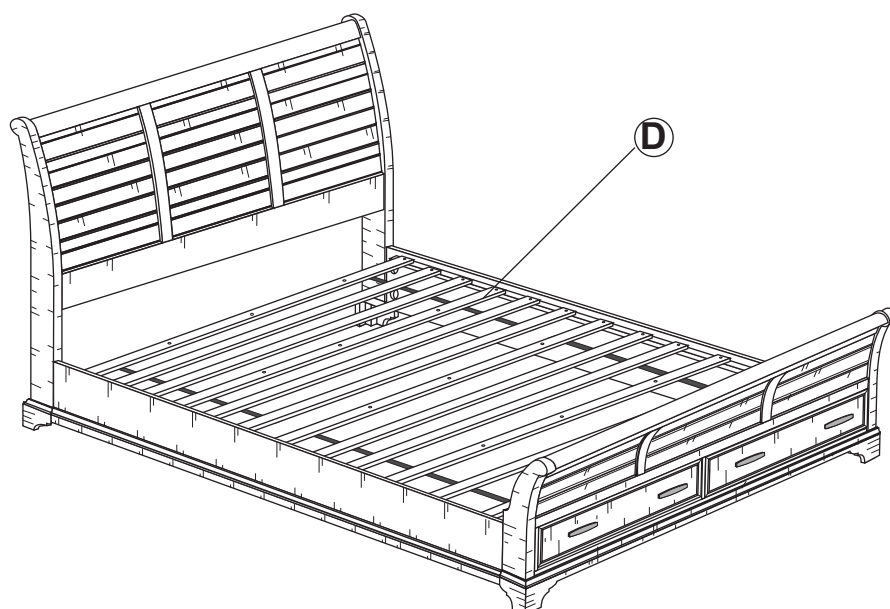

ITEM: 203891Q (B1 - B3)

ASSEMBLY INSTRUCTIONS



STEP 5

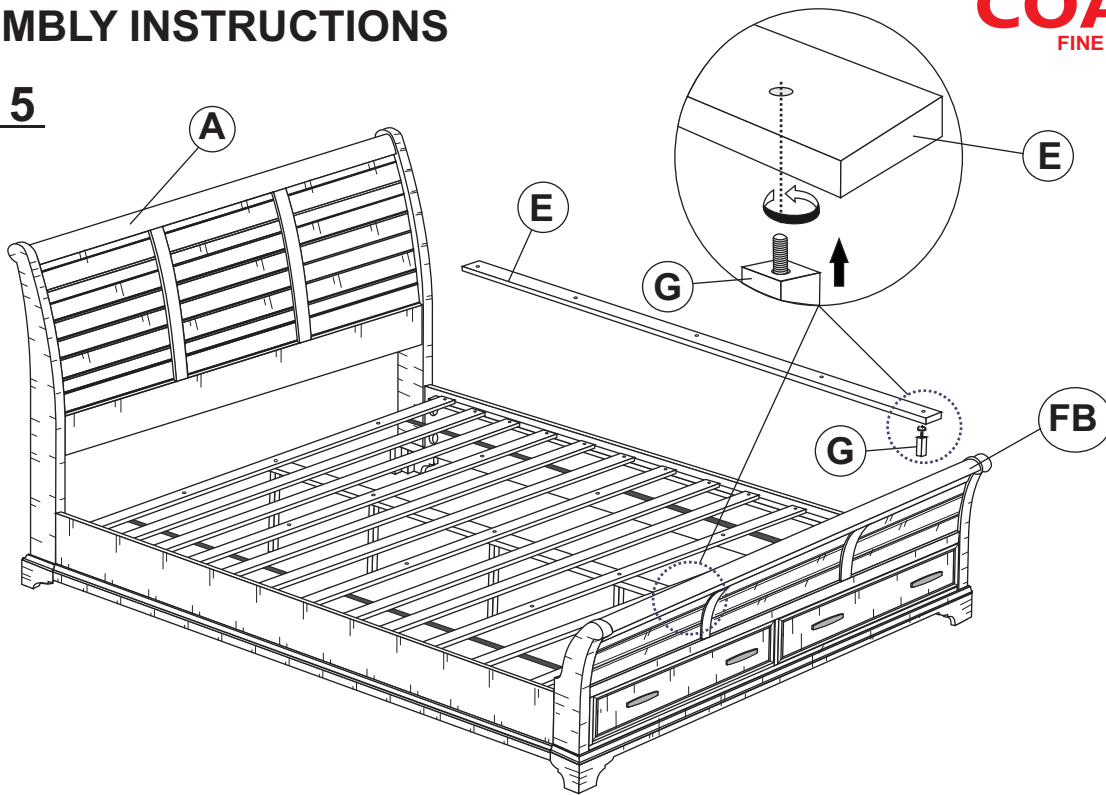

STEP 6

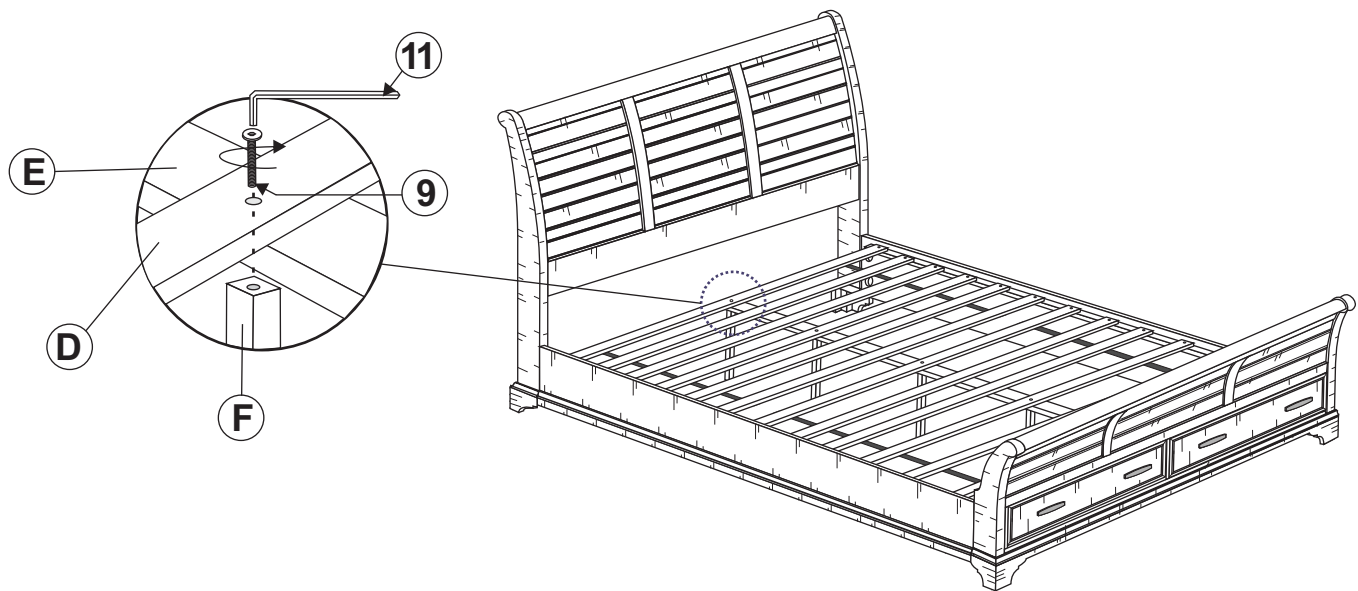

ITEM: **203891Q (B1 - B3)**

ASSEMBLY INSTRUCTIONS



STEP 7

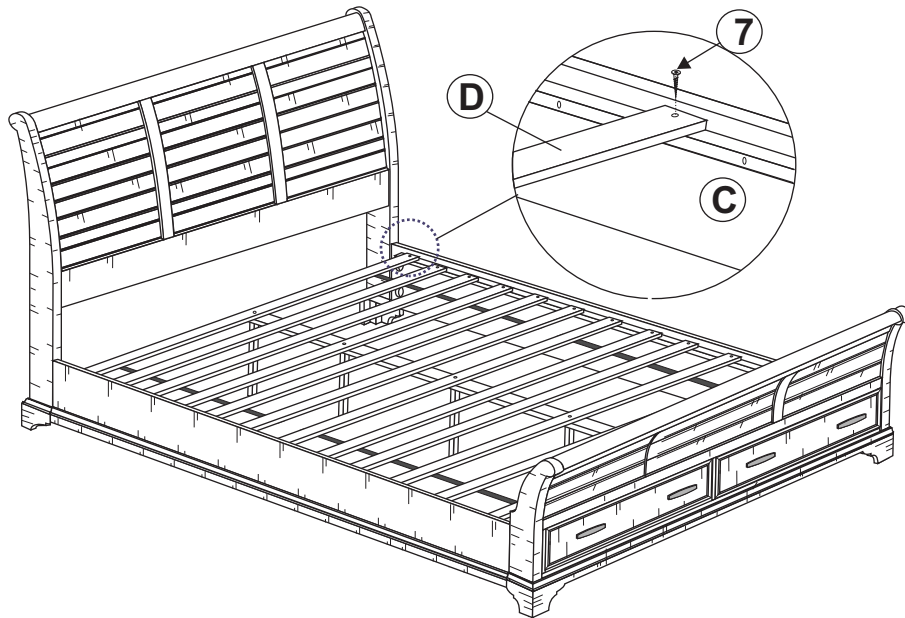

STEP 8

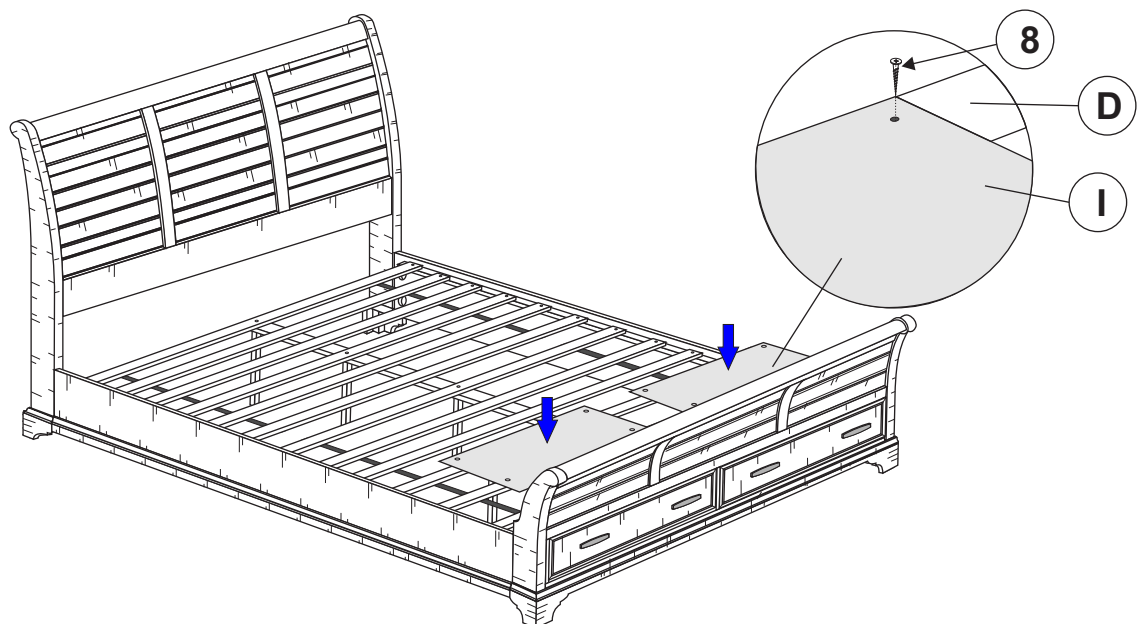

ITEM: **203891Q (B1 - B3)**

ASSEMBLY INSTRUCTIONS



STEP 9

COMPLETE

