

ASSEMBLY INSTRUCTIONS
COASTER FINE FURNITURE

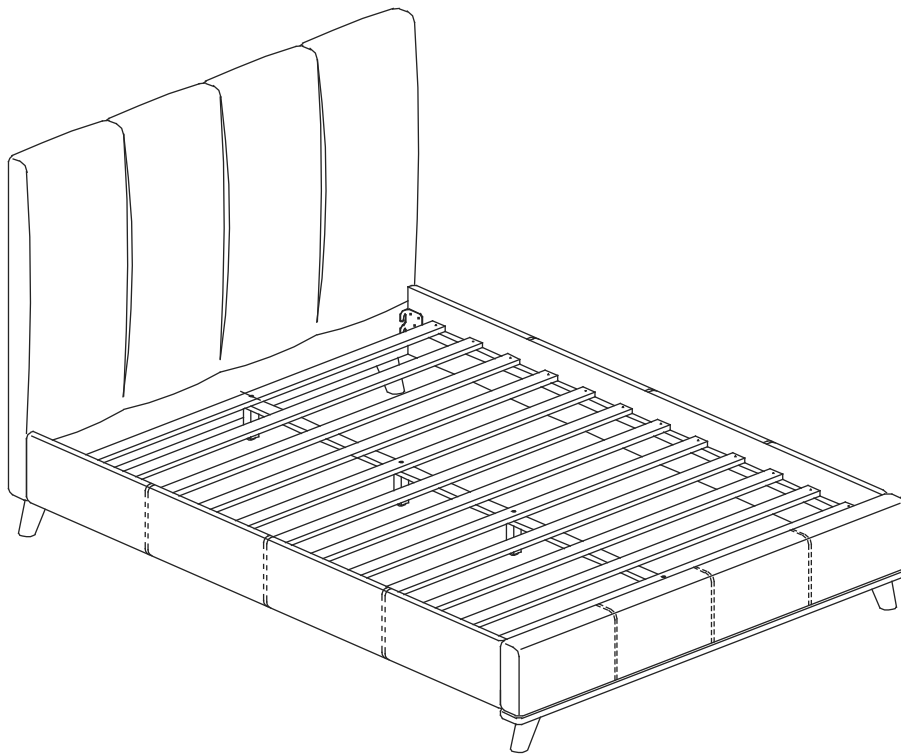

Fine Furniture for every stage of life

300626F (B1-B3)
Full Bed

ITEM: 300626F (B1-B3)



ASSEMBLY INSTRUCTIONS

ASSEMBLY TIPS:

1. Remove hardware from box and sort by size.
2. Please check to see that all hardware and parts are present prior to start of assembly.
3. Please follow attached instructions in the same sequence as numbered to assure fast & easy assembly.



WARNING!

1. Don't attempt to repair or modify parts that are broken or defective. Please contact the store immediately.
2. This product is for home use only and not intended for commercial establishments.



ASSEMBLY TIME

30 MINUTES

PARTS IDENTIFICATION

B1 (BOX 1)

A HEADBOARD PANEL



1PC

B BED SLAT WITH HOLES



4PCS

C BED SLAT WITHOUT HOLES



8PCS

B2 (BOX 2)

D FOOTBOARD PANEL

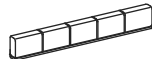

1PC

B3 (BOX 3)

E BED RAIL



2PCS

F HEADBOARD LEG



2PCS

G FOOTBOARD LEG



2PCS

H CENTER RAIL



1PC

I CENTER RAIL SUPPORT WITH LEVELER



4PCS

NOTE:

Phillips head screw driver is required in the assembly process; however, manufacturer does not provided this item.

ITEM: 300626F (B1-B3)

ASSEMBLY TIPS:

1. Remove hardware from box and sort by size.
2. Please check to see that all hardware and parts are present prior to start of assembly.
3. Please follow attached instructions in the same sequence as numbered to assure fast & easy assembly.









WARNING!

1. Don't attempt to repair or modify parts that are broken or defective. Please contact the store immediately.
2. This product is for home use only and not intended for commercial establishments.

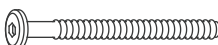
HARDWARE IDENTIFICATION

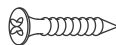
Z-B3 (BOX 3) - HARDWARE PACK IS LOCATED IN 300626F (B3)

1	SHORT BOLT (M8 x 20MM - RBW)		8PCS
2	MEDIUM BOLT (M6 x 50MM - RBW)		4PCS
3	LONG BOLT (M6 x 60MM - RBW)		4PCS
4	WOOD DOWEL (M8Ø x 30mm)		4PCS
5	FLAT HEAD SCREW (M4 x 32MM - RBW)		24PCS
6	SMALL ALLEN WRENCH (M4 x 100MM - BLK)		1PC
7	BIG ALLEN WRENCH (M5 x 65MM - BLK)		1PC

NOTE:

Phillips head screw driver is required in the assembly process; however, manufacturer does not provided this item.

ITEM: 300626F (B1-B3)

ASSEMBLY INSTRUCTIONS

STEP 1

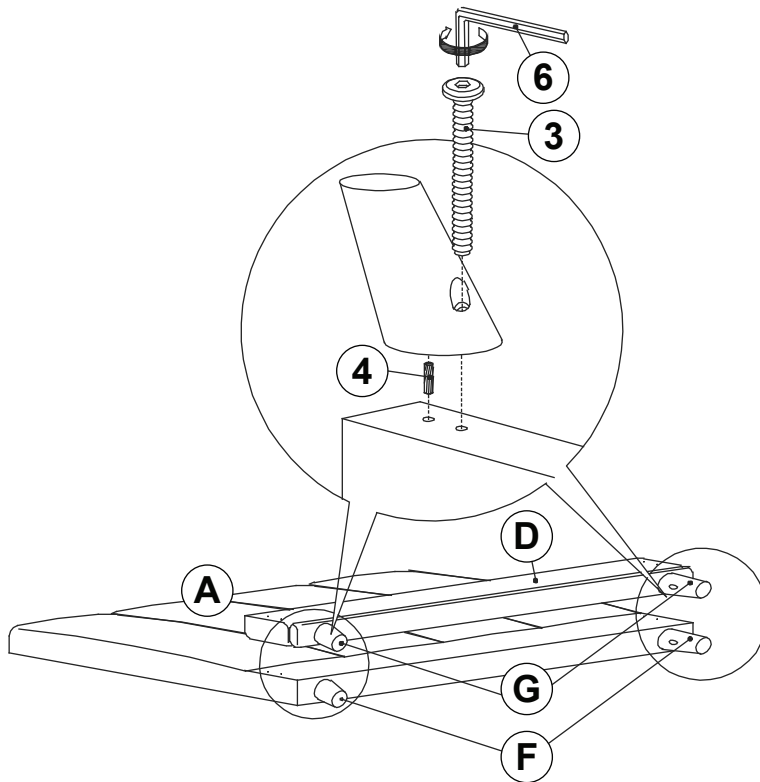

STEP 2

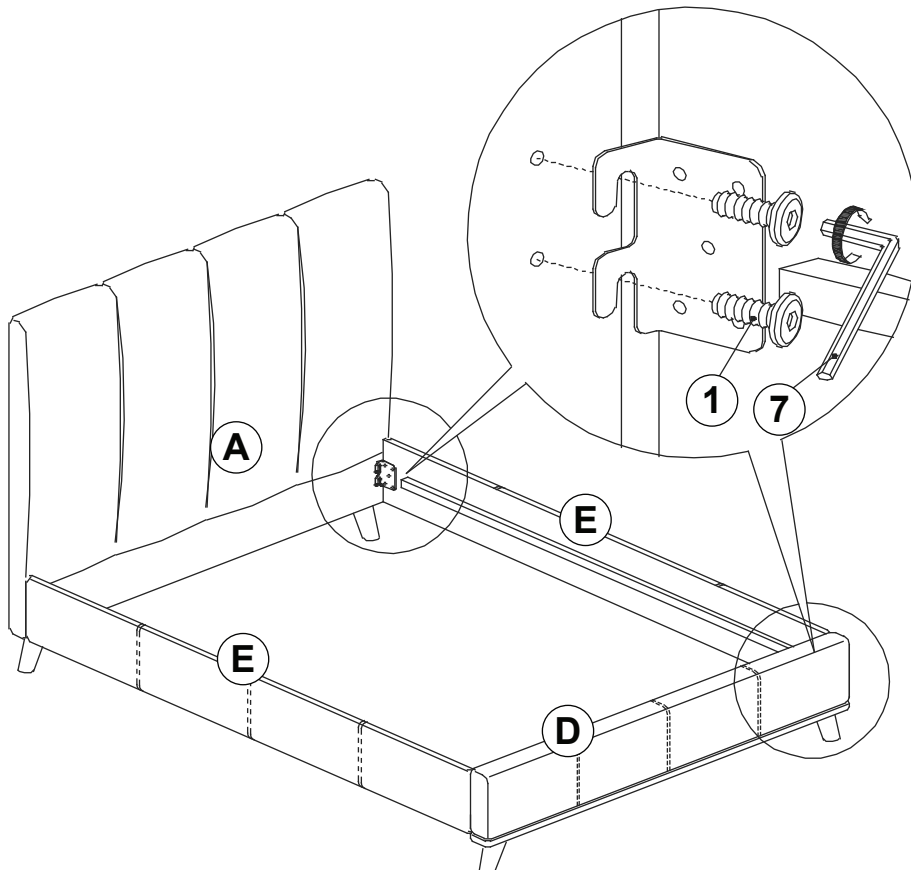

ITEM: 300626F (B1-B3)

ASSEMBLY INSTRUCTIONS

STEP 3

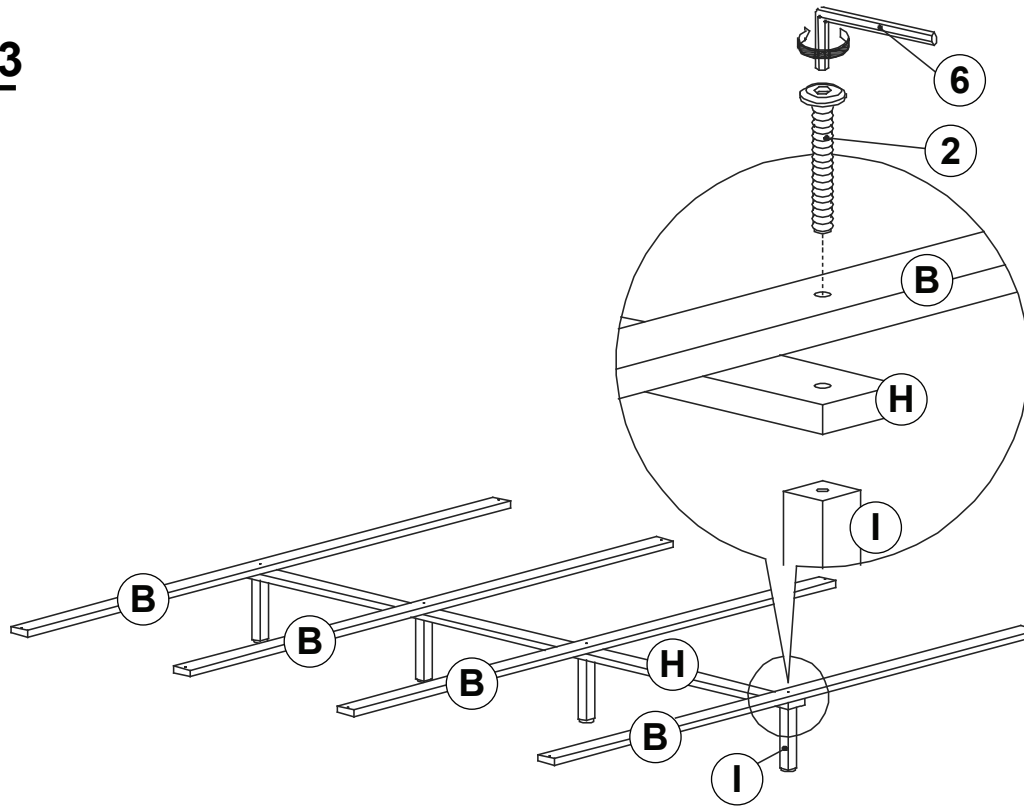

STEP 4

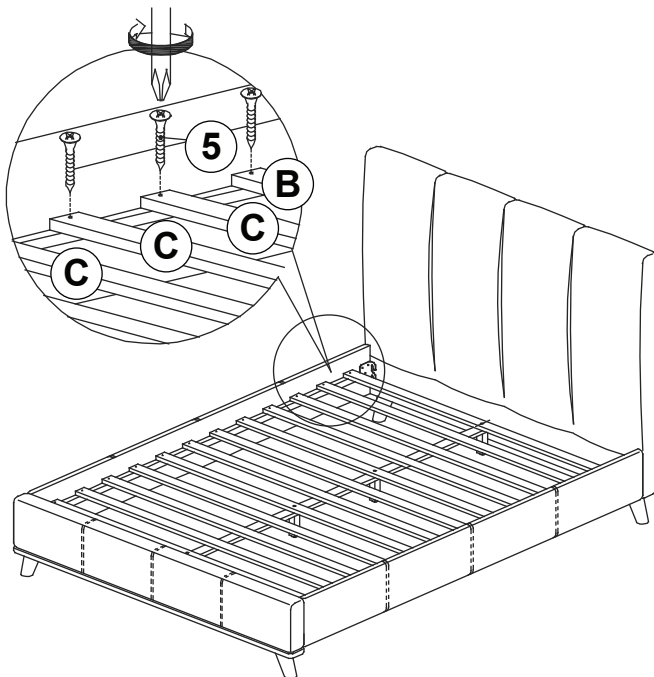

STEP 5

COMPLETE

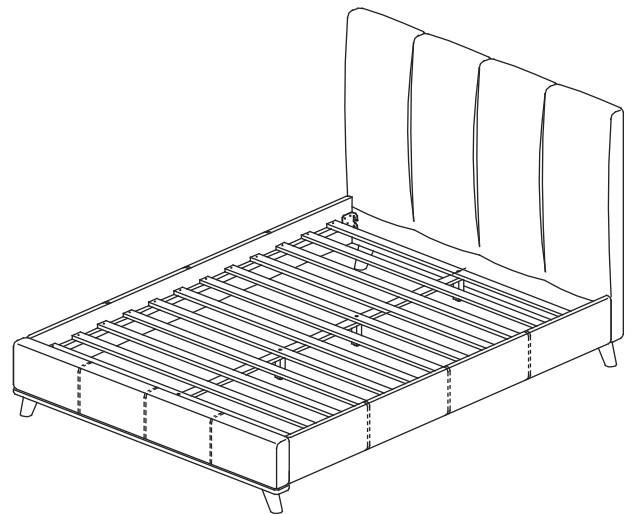

ITEM: 300626F (B1-B3)

INNER SIZE : 54.49" x 75.39"

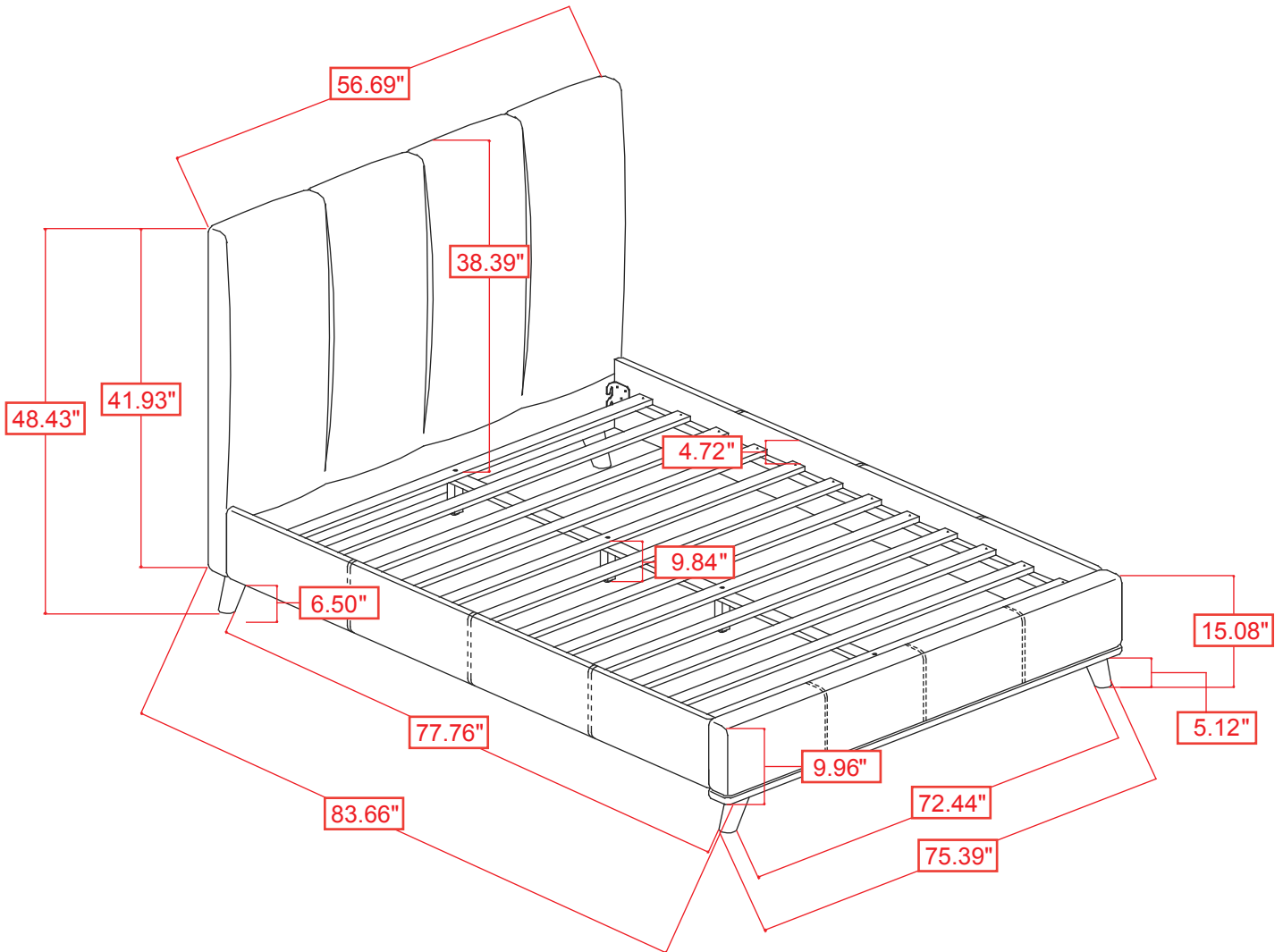

Note: Dimension tolerance $\pm 5\%$