

ASSEMBLY INSTRUCTIONS
COASTER FINE FURNITURE



Fine Furniture for every stage of life

804495
Writing Desk

ITEM: **804495**



ASSEMBLY INSTRUCTIONS

ASSEMBLY TIPS:

1. Remove hardware from box and sort by size.
2. Please check to see that all hardware and parts are present prior to start of assembly.
3. Please follow attached instructions in the same sequence as numbered to assure fast & easy assembly.



WARNING!

1. Don't attempt to repair or modify parts that are broken or defective. Please contact the store immediately.
2. This product is for home use only and not intended for commercial establishments.



ASSEMBLY TIME

30 MINUTES

PARTS IDENTIFICATION

A	BACK PANEL		1PC
B	LARGE SHELF PANEL		1PC
C	LEFT SIDE PANEL		1PC
D	RIGHT SIDE PANEL		1PC
E	SMALL SHELF PANEL		1PC
F	RIGHT DIVIDER		1PC
G	LEFT DIVIDER		1PC
H	TOP		1PC
I	LEG		4PCS

NOTE:

Phillips head screw driver is required in the assembly process; however, manufacturer does not provide this item.

ASSEMBLY INSTRUCTIONS

ASSEMBLY TIPS:









1. Remove hardware from box and sort by size.
2. Please check to see that all hardware and parts are present prior to start of assembly.
3. Please follow attached instructions in the same sequence as numbered to assure fast & easy assembly.

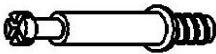

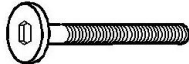
WARNING!

1. Don't attempt to repair or modify parts that are broken or defective. Please contact the store immediately.
2. This product is for home use only and not intended for commercial establishments.

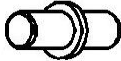
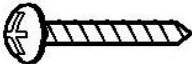
HARDWARE IDENTIFICATION

1	CAM BOLT (24mm - RBW)		15PCS
2	CAM NUT (9mm - RBW)		15PCS
3	BOLT (M8 x 60mm - RBW)		8PCS
4	LOCK WASHER (5/16" - RBW)		8PCS
5	FLAT WASHER (5/16" - RBW)		8PCS
6	WOOD DOWEL (M8X30mm)		22PCS
7	SHELF SUPPORT (5mm)		4PCS
8	PAN HEAD SCREW (#8 x 1/4" - BLK)		2PCS
9	ALLEN WRENCH (M5 - BLK)		1PC
10	CAP (WHITE)		7PCS

NOTE:

Phillips head screw driver is required in the assembly process; however, manufacturer does not provide this item.

ITEM: **804495**



ASSEMBLY INSTRUCTIONS
STEP 1

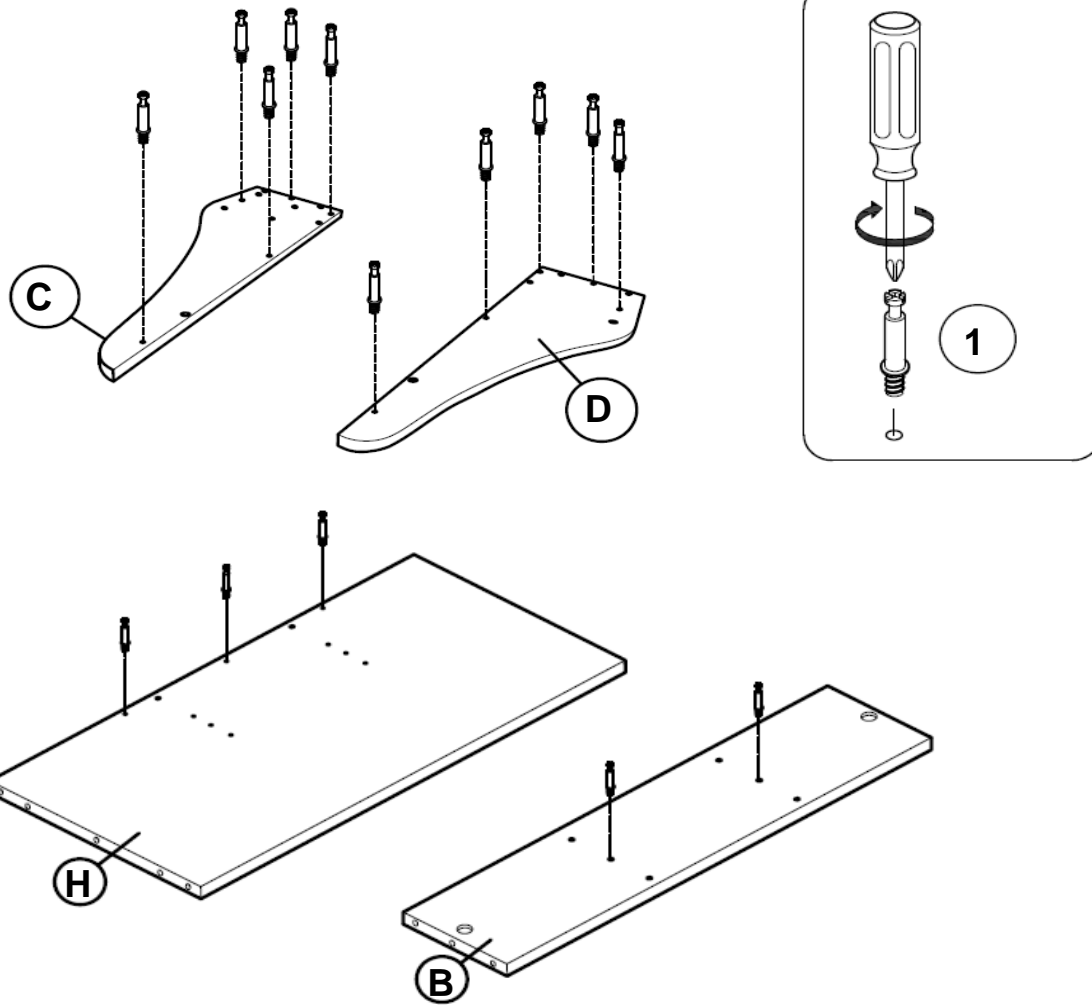

STEP 2

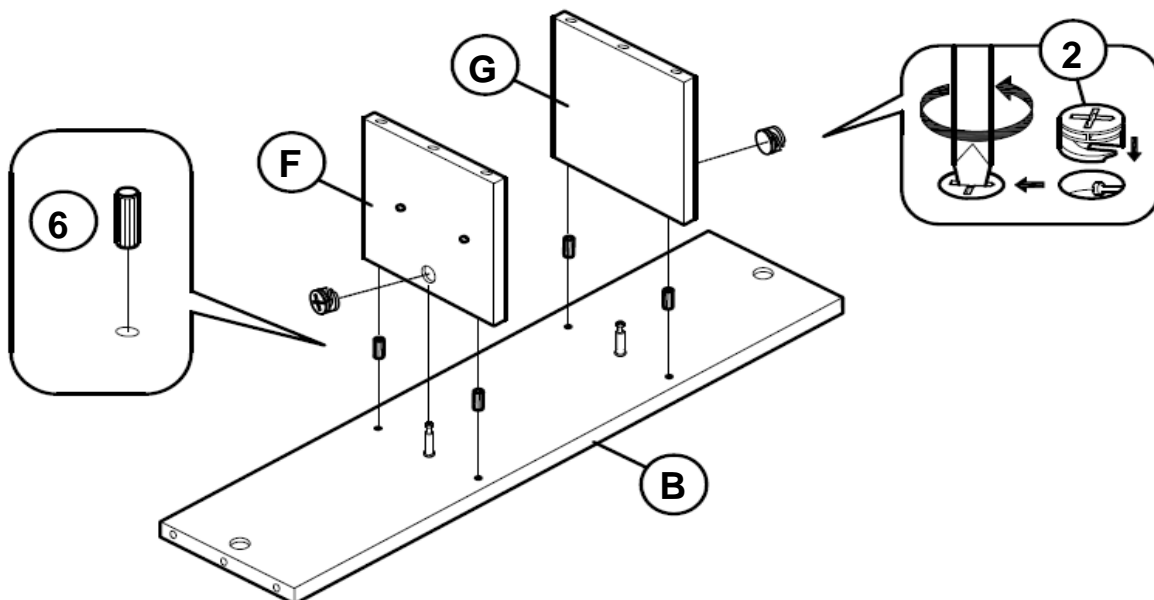

ITEM: **804495**



ASSEMBLY INSTRUCTIONS
STEP 3

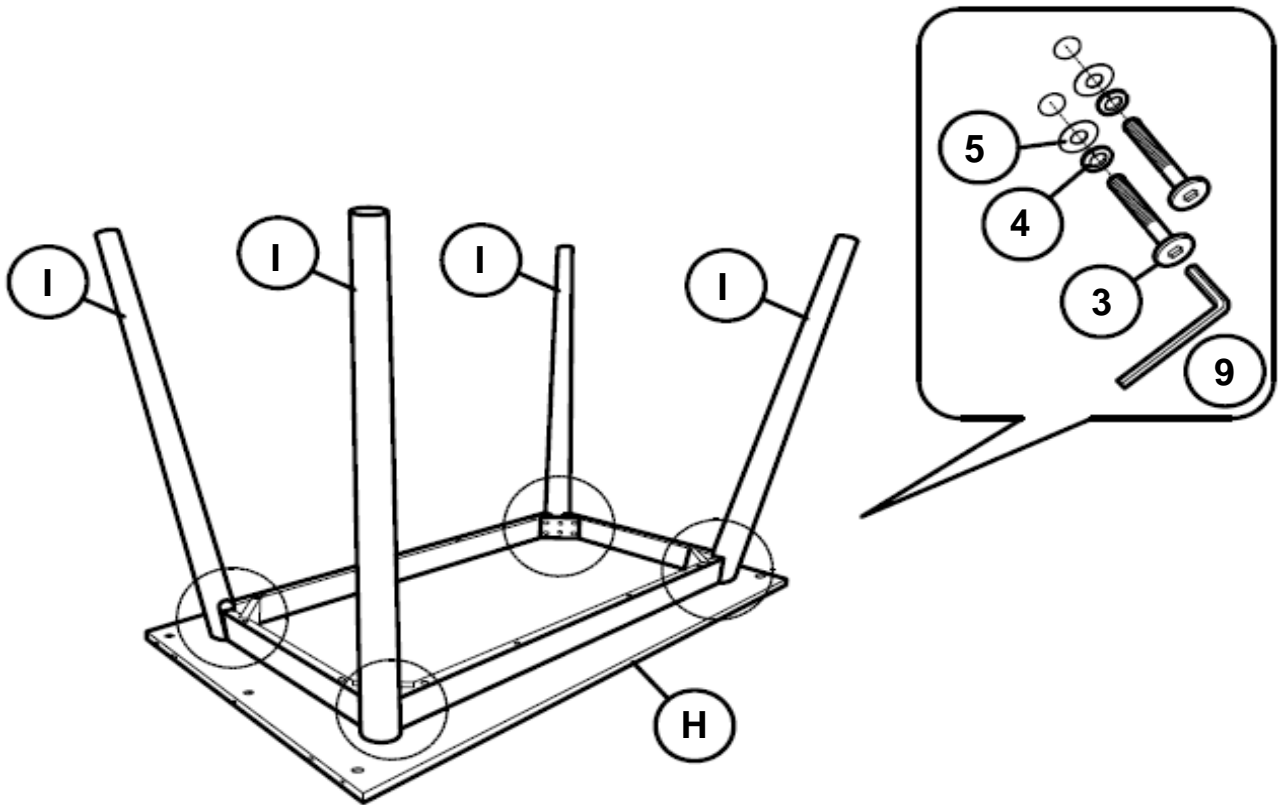

STEP 4

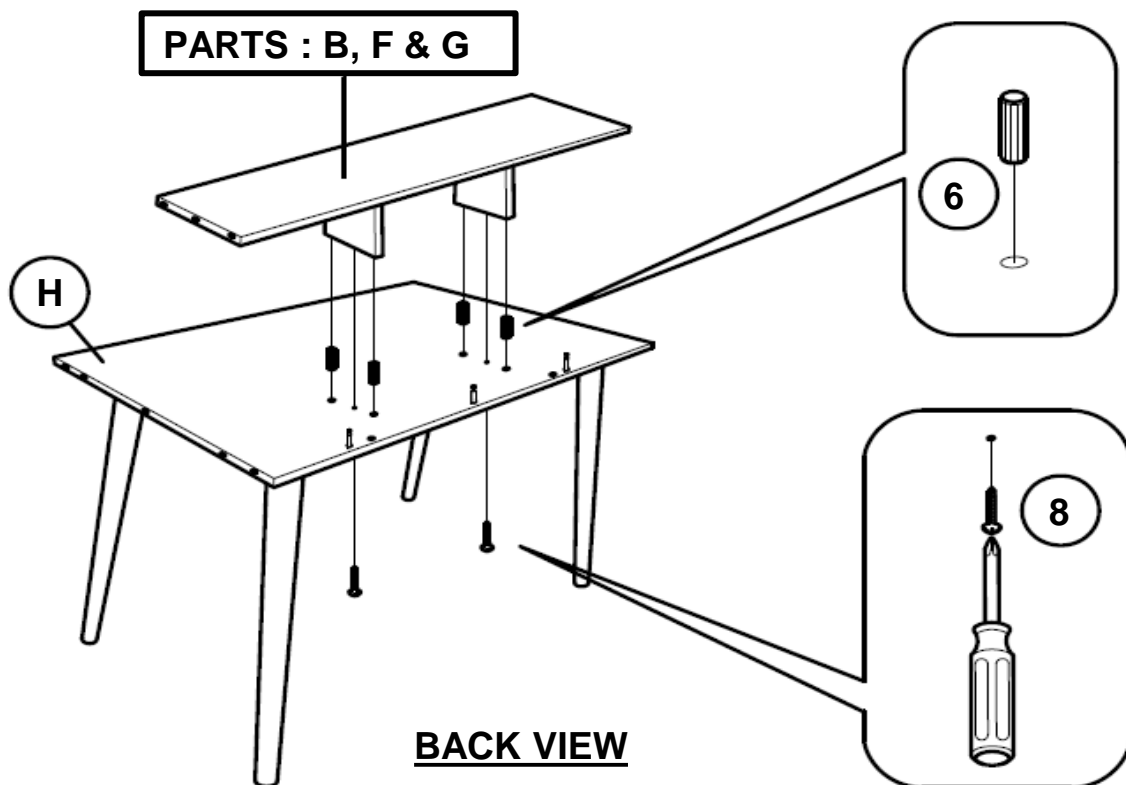

ITEM: 804495

ASSEMBLY INSTRUCTIONS
STEP 5

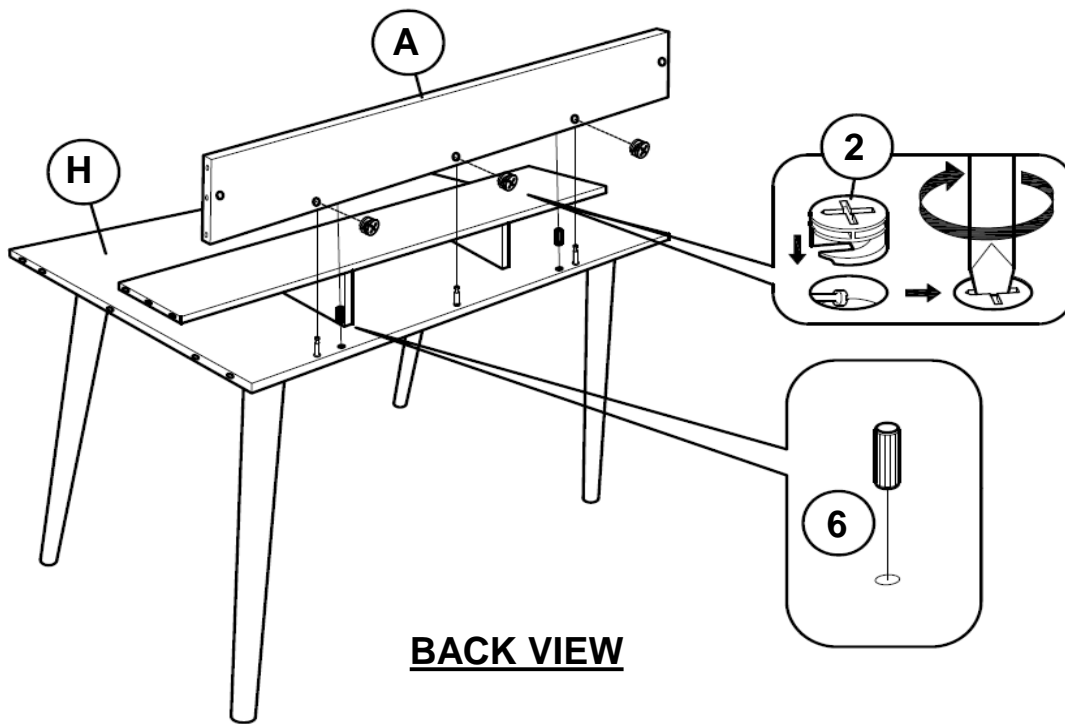

BACK VIEW

STEP 6

BACK VIEW

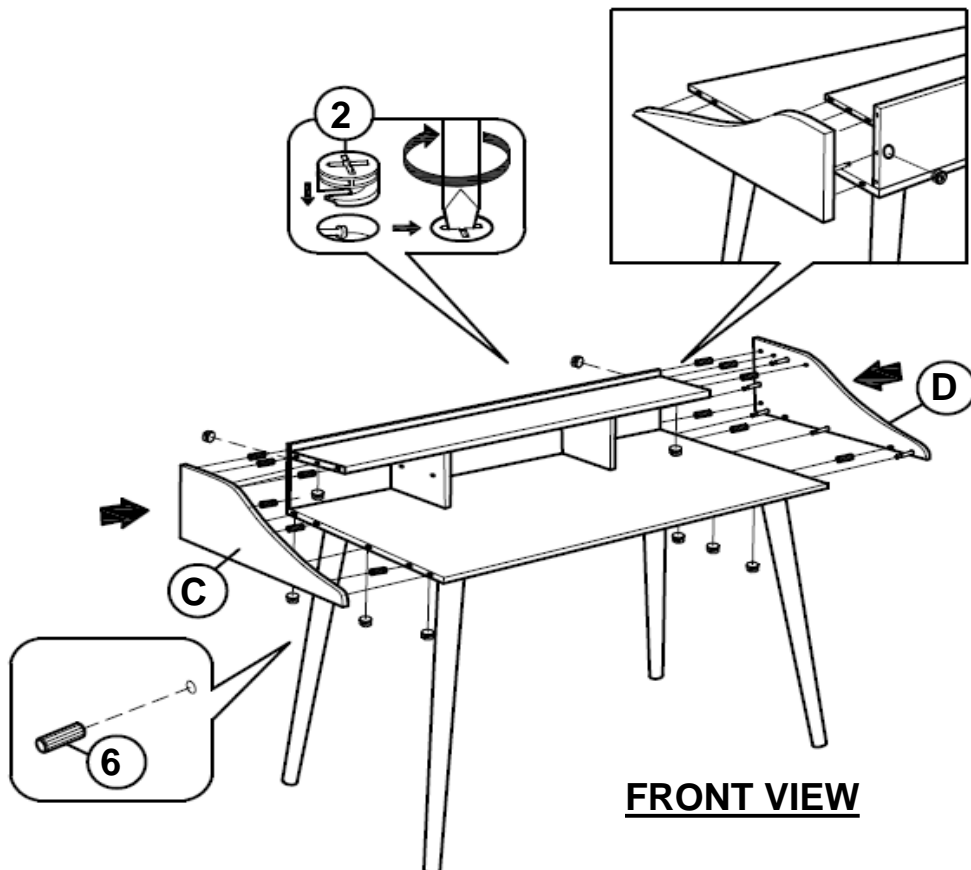

FRONT VIEW

ITEM: **804495**



ASSEMBLY INSTRUCTIONS
STEP 7

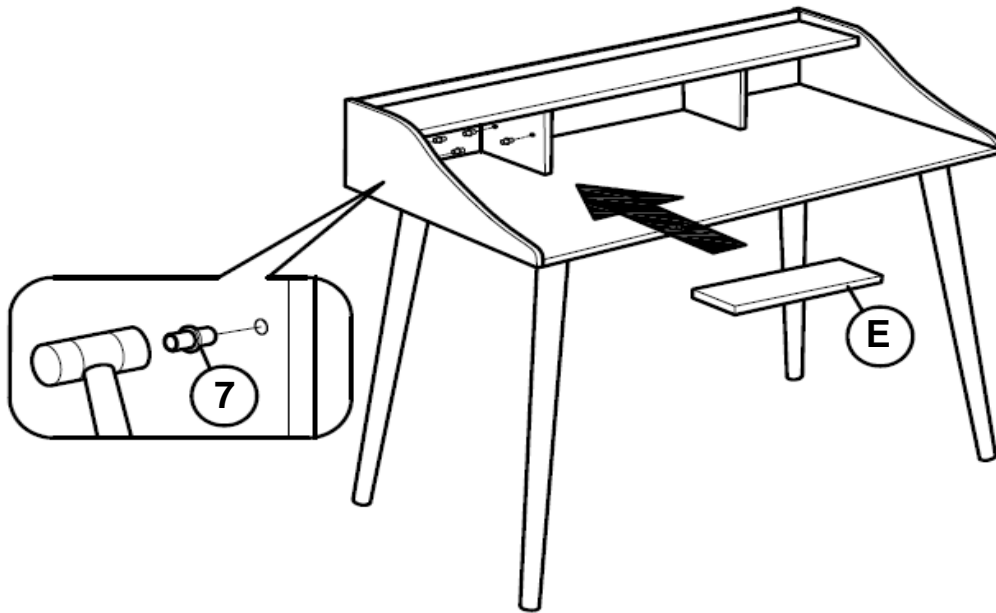

STEP 8

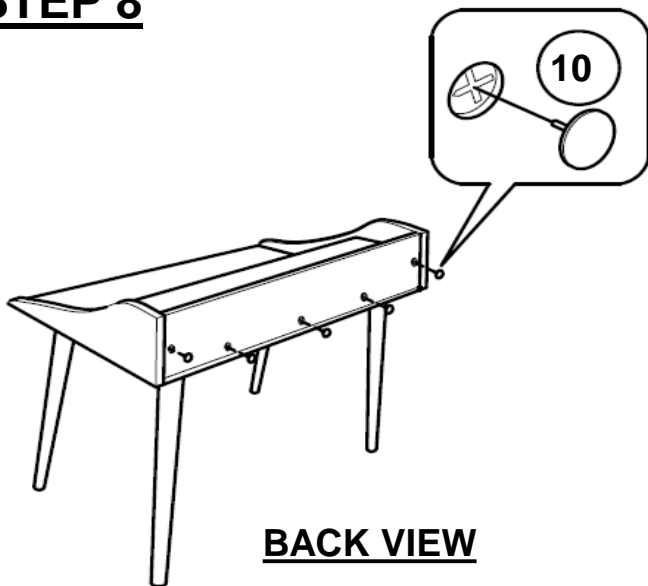

BACK VIEW

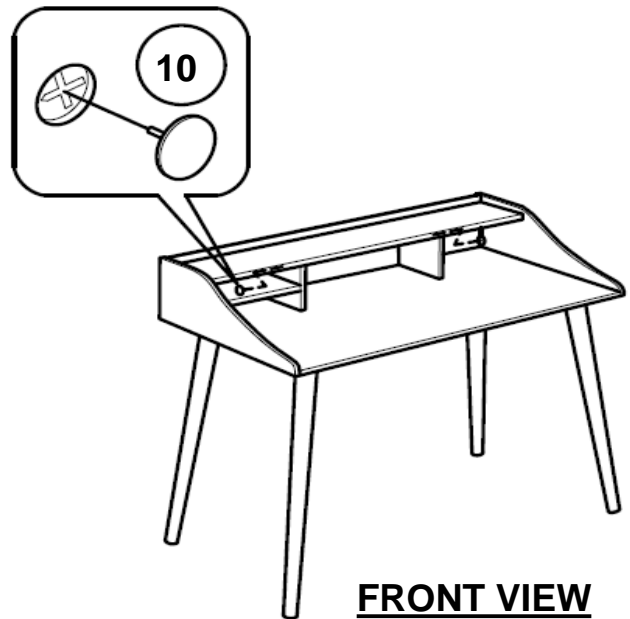

FRONT VIEW

STEP 9
COMPLETE

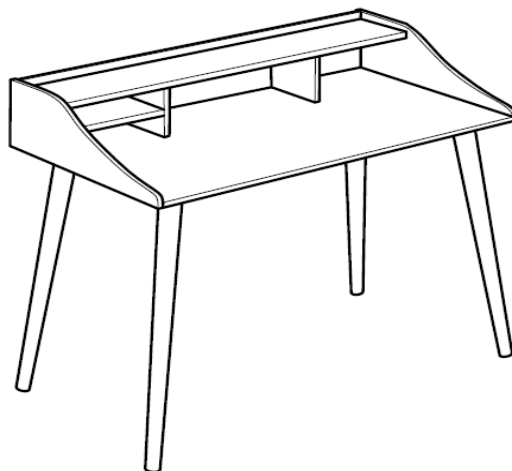

ITEM: 804495

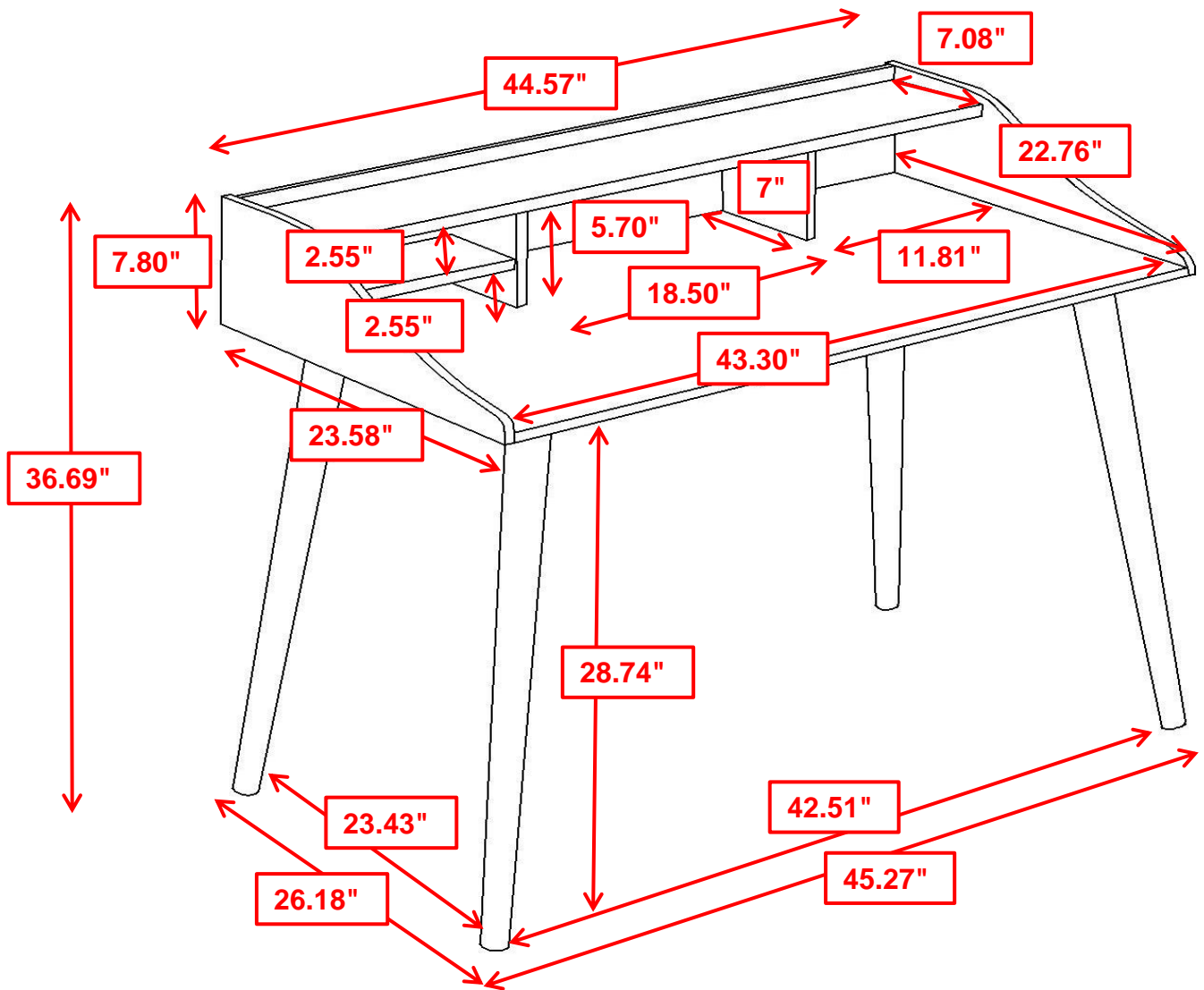

Note : Dimension tolerance $\pm 5\%$