

ASSEMBLY INSTRUCTIONS COASTER FINE FURNITURE



Fine Furniture for every stage of life

109401(B1-B2)
Dining Table

ITEM: 109401(B1-B2)



ASSEMBLY INSTRUCTIONS

ASSEMBLY TIPS:

1. Remove hardware from box and sort by size.
2. Please check to see that all hardware and parts are present prior to start of assembly.
3. Please follow attached instructions in the same sequence as numbered to assure fast & easy assembly.



WARNING !

1. Don't attempt to repair or modify parts that are broken or defective. Please contact the store immediately.
2. This product is for home use only and not intended for commercial establishments.

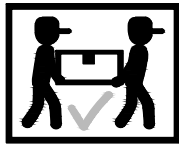

ASSEMBLY TIME 30 MINUTES

PARTS IDENTIFICATION

B1 (BOX 1)

A. TOP

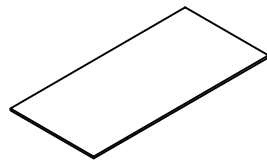

1PC

B2 (BOX 2)

B. BASE

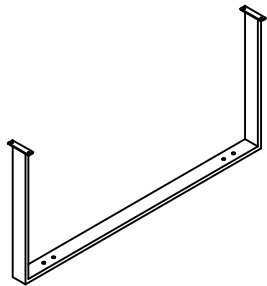

1PC

C. LEG

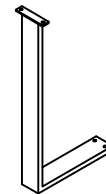

4PCS

HARDWARE PACKAGE

Z-B2 (BOX 2)-HARDWARE PACK IS LOCATED IN 109401(B2)

1. ALLEN WRENCH
(Ø5/16"*63mm-SILVER)



1PC

3. CONNECTING PLATE
(170mm*70mm-SILVER)



2PCS

2. BOLT
(Ø5/16"*20mm-SILVER)



24PCS

ITEM: **109401(B1-B2)**

ASSEMBLY INSTRUCTIONS



STEP 1

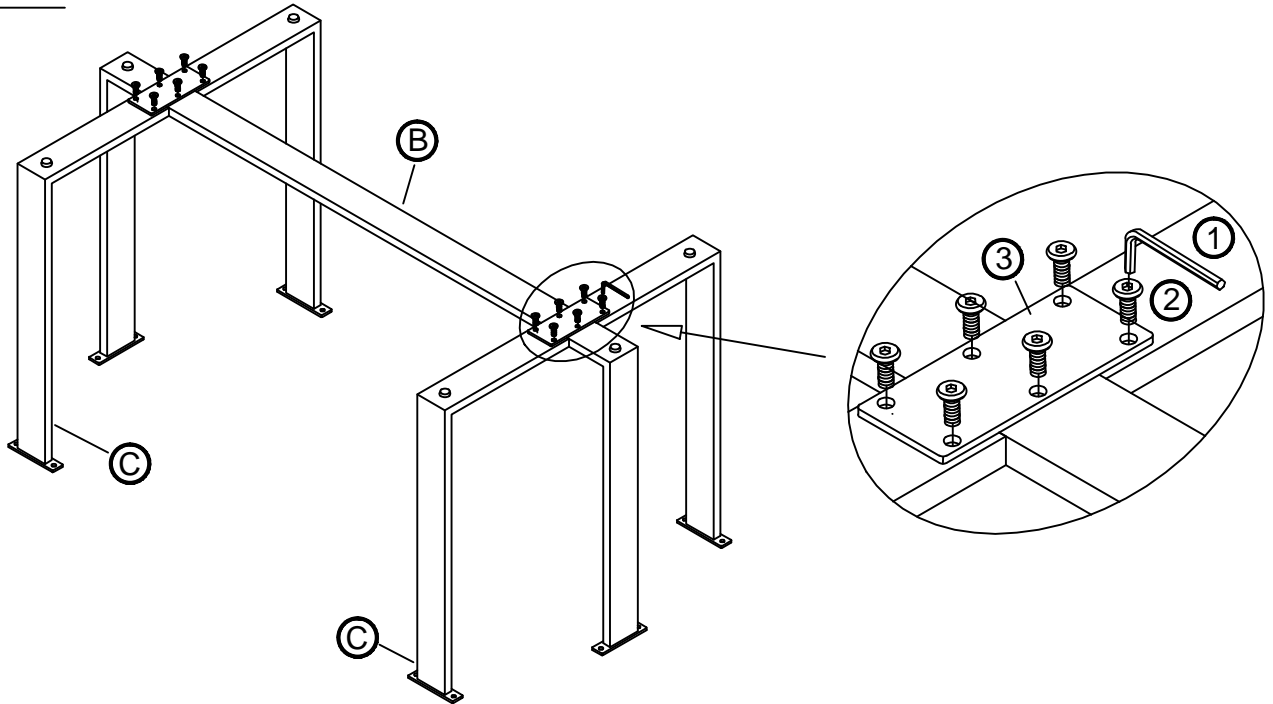

STEP 2

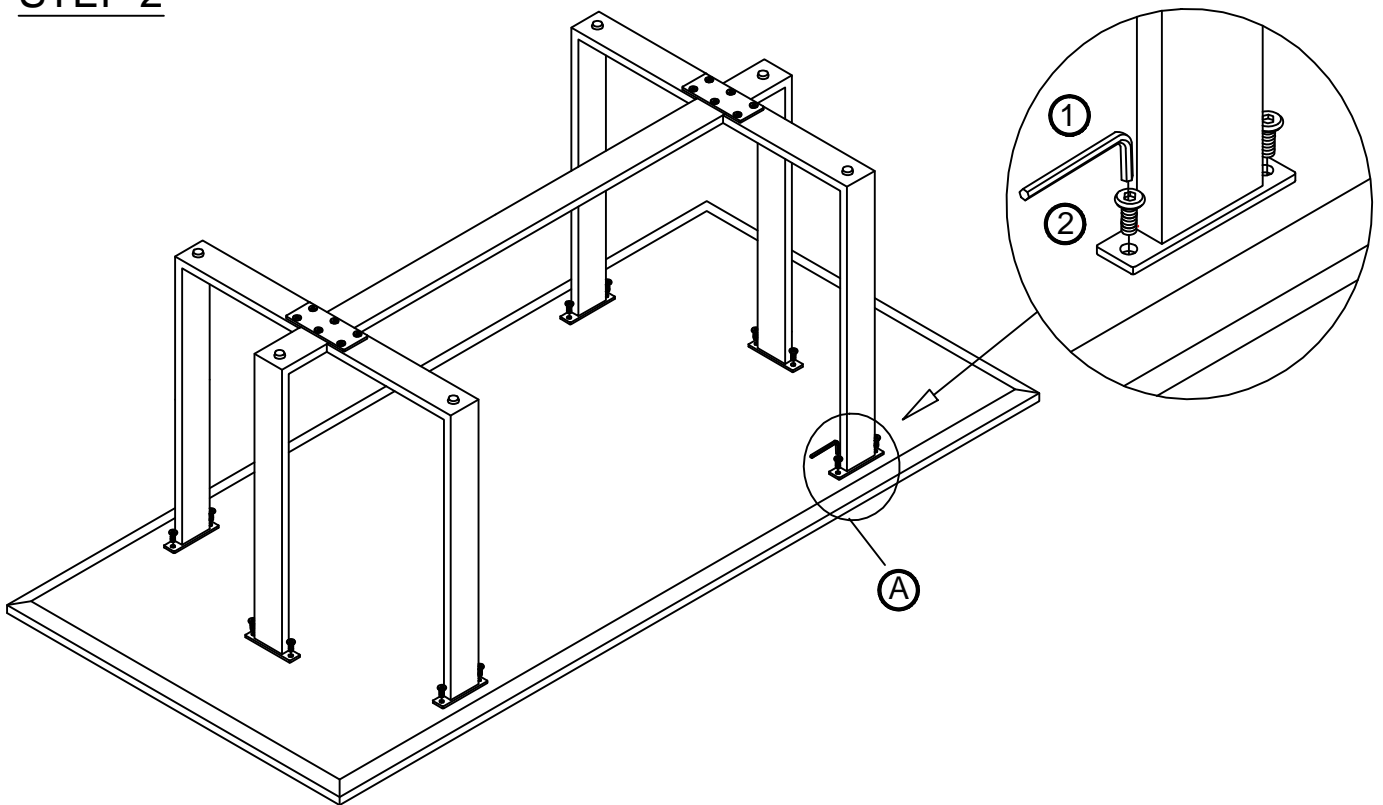

ITEM: **109401(B1-B2)**

ASSEMBLY INSTRUCTIONS



STEP 3
COMPLETE

