

ASSEMBLY INSTRUCTIONS
COASTER FINE FURNITURE



Fine Furniture for every stage of life

130078
BAR UNIT

REVISION 0 : 10/06/2017
REVISION 1 : 05/25/2020

ITEM:130078



ASSEMBLY INSTRUCTIONS

ASSEMBLY TIPS:

1. Remove hardware from box and sort by size.
2. Please check to see that all hardware and parts are present prior to start of assembly.
3. Please follow attached instructions in the same sequence as numbered to assure fast & easy assembly.



WARNING!

1. Don't attempt to repair or modify parts that are broken or defective. Please contact the store immediately.
2. This product is for home use only and not intended for commercial establishments.



ASSEMBLY TIME 60 MINUTES

PARTS IDENTIFICATION

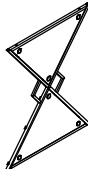
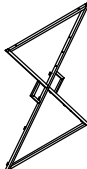
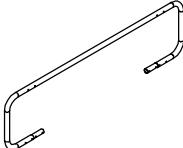
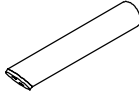
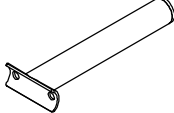
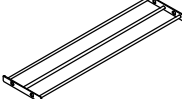
A	FRONT FRAME		1PC
B	BACK FRAME		1PC
C	FOOTREST		1PC
D	SHORT CROSSBAR		2PCS
E	SUPPORT LEG		4PCS
F	BOTTLE RACK		4PCS

ITEM:130078

ASSEMBLY INSTRUCTIONS

PARTS IDENTIFICATION



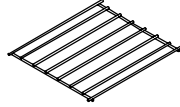
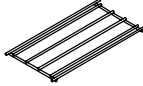
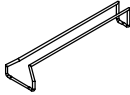
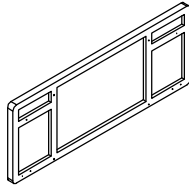
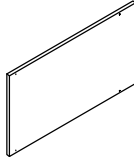
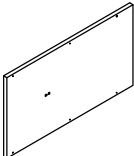









G	LARGE SHELF		2PCS
H	MIDDLE SHELF		1PC
I	SMALL SHELF		1PC
J	GLASS HOLDER		2PCS
K	TOP		1PC
L	TOP SIDE PANEL		2PCS
M	BOTTOM SIDE PANEL		2PCS

ITEM:130078

ASSEMBLY INSTRUCTIONS

HARDWARE IDENTIFICATION



1	LONG BOLT (1/4" x 32mm SR)		4PCS
2	LONG ALLEN BOLT (1/4" x 35mm SR)		4PCS
3	SHORT ALLEN BOLT (1/4" x 28mm SR)		12PCS
4	MIDDLE BOLT (1/4" x 22mm SR)		4PCS
5	SHORT BOLT (1/4" x 13mm SR)		12PCS
6	WINE BOLT (3/16" x 12mm SR)		16PCS
7	SCREW (4 x 12mm SR)		26PCS
8	LARGE LEVELER (5/16" x 25mm BLK)		4PCS
9	SMALL LEVELER (1/4" x 15mm BLK)		4PCS
10	ALLEN WRENCH (4mm)		1PC

ITEM: 130078 ASSEMBLY INSTRUCTIONS



STEP 1 Do not tighten until each step is completed or instructed.

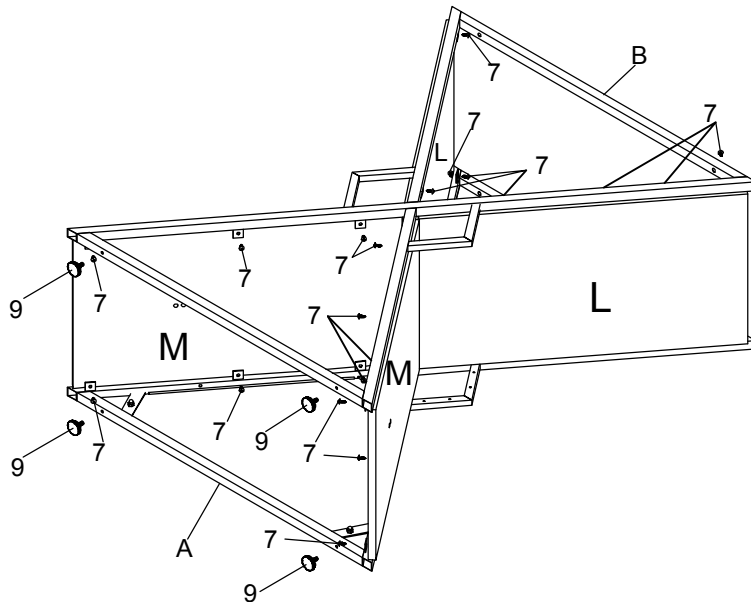

STEP 2

Same as the other side, to use #6 8pcs to assemble.

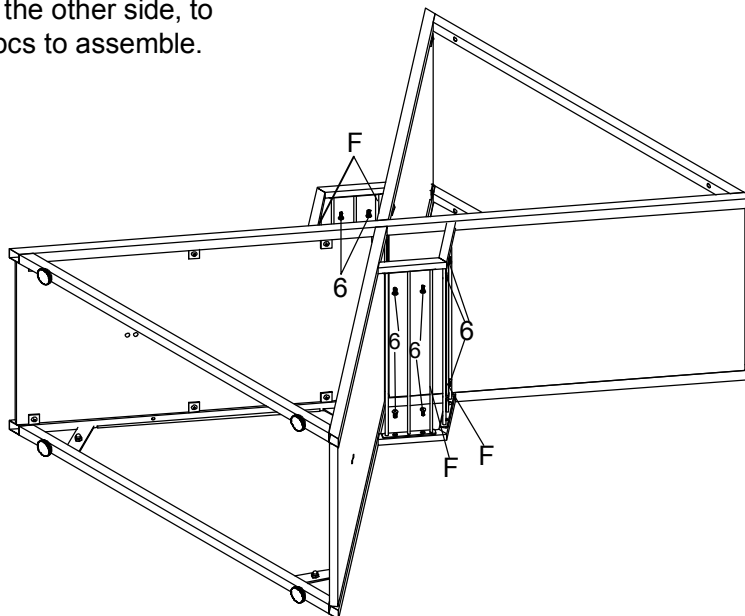

ITEM: 130078
ASSEMBLY INSTRUCTIONS
STEP 3

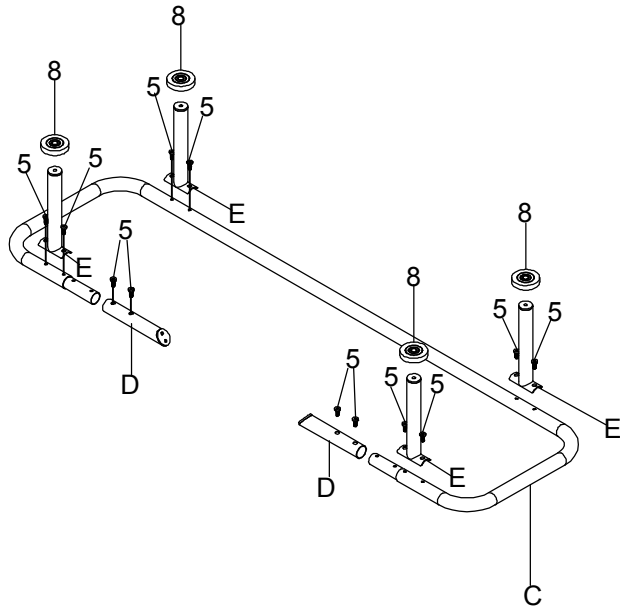

STEP 4

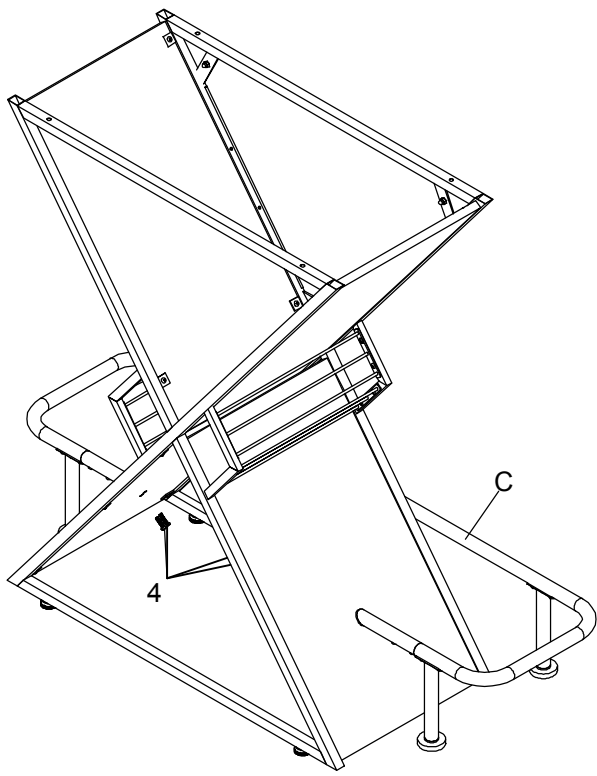

ITEM: 130078
ASSEMBLY INSTRUCTIONS
STEP 5



Same as the other side,
use #7 3pcs to assemble.

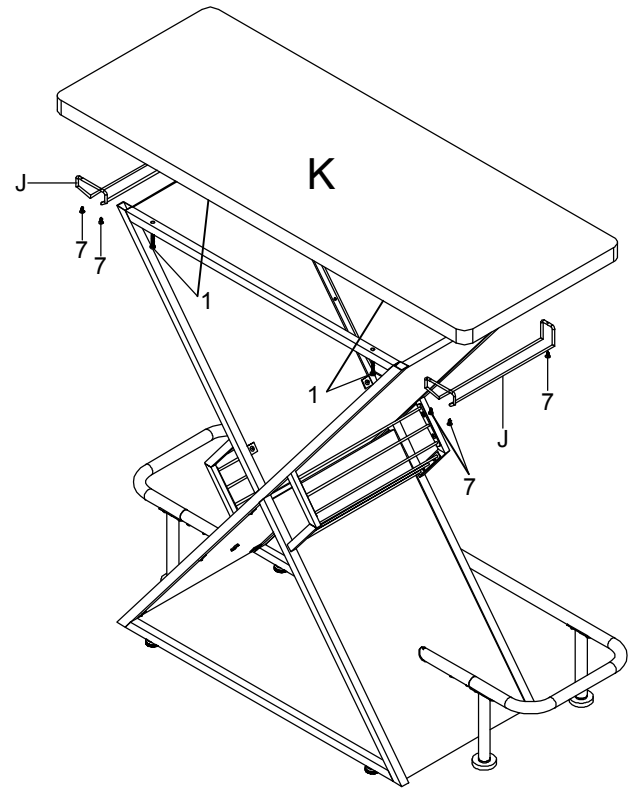

STEP 6

Same as the other side, use
#3 6pcs to assemble.

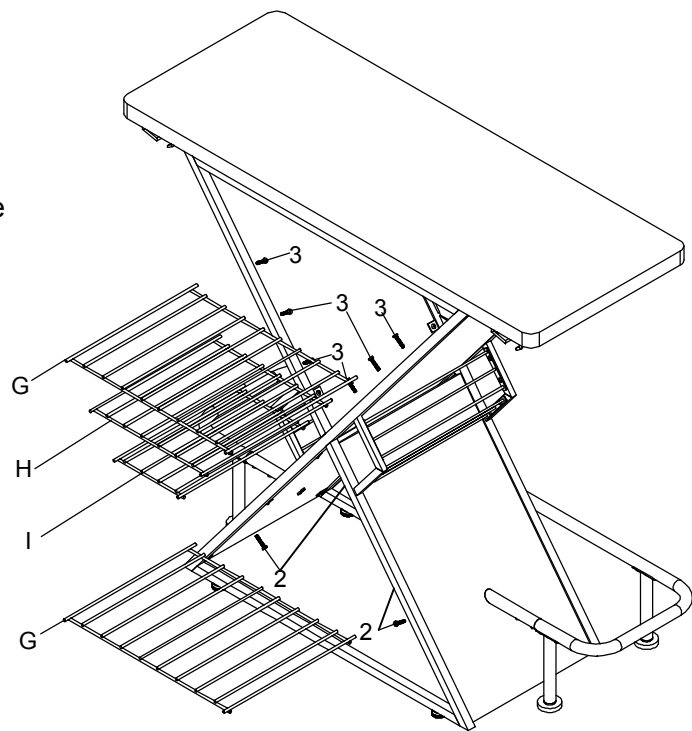

ITEM: 130078
ASSEMBLY INSTRUCTIONS



STEP 7
COMPLETE

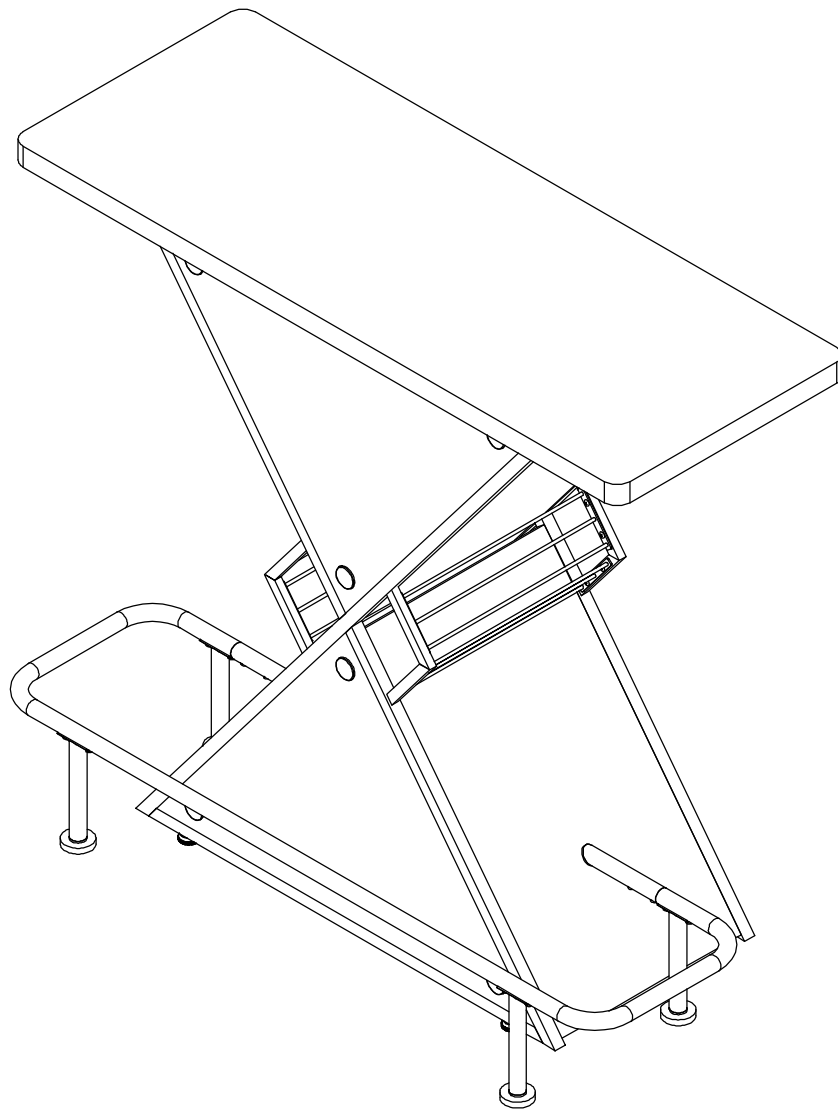

How to clean Acrylic product:
Using a dry soft microfiber cloth, lightly brush off any dust.
For additional care, dampen the cloth with warm water.
For deepest cleaning, use an Acrylic cleaner.

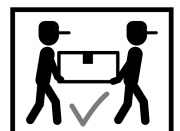

ITEM:130078 ASSEMBLY INSTRUCTIONS

Product Size : 1200 X 502 X 1079 H (MM)

Product Size : 47 $\frac{1}{4}$ " X 19 $\frac{3}{4}$ " X 42 $\frac{1}{2}$ "

The thickness of the metal is:1.2mm

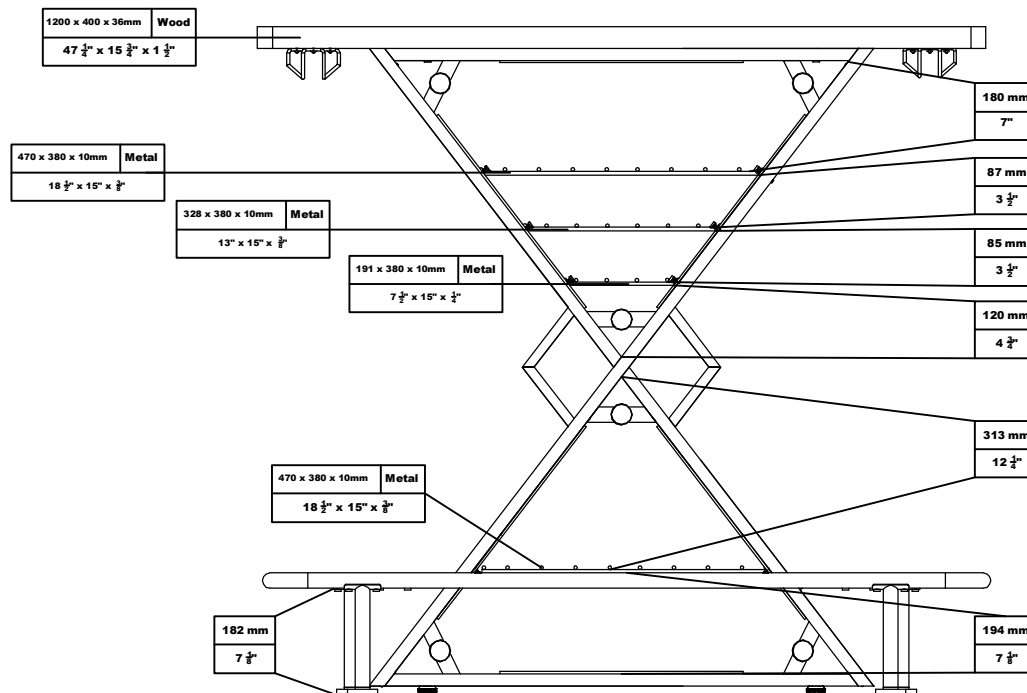
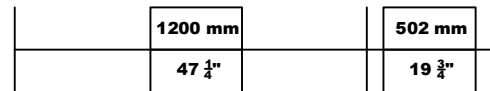
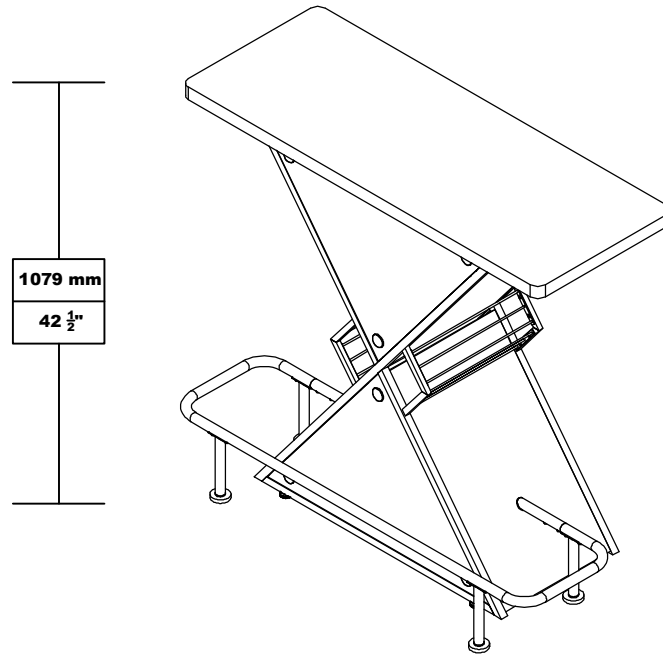

Note : Dimension tolerance $\pm 5\%$