



*ASSEMBLY INSTRUCTIONS*  
*COASTER FINE FURNITURE*



**183437**  
**BAR STOOL**

ITEM: **183437**



## ASSEMBLY INSTRUCTIONS

### ASSEMBLY TIPS:

1. Remove hardware from box and sort by size.
2. Please check to see that all hardware and parts are present prior to start of assembly.
3. Please follow attached instructions in the same sequence as numbered to assure fast & easy assembly.



### WARNING!

1. Don't attempt to repair or modify parts that are broken or defective. Please contact the store immediately.
2. This product is for home use only and not intended for commercial establishments.



ASSEMBLY TIME

5 MINUTES

## PARTS IDENTIFICATION

A BACK CUSHION



1PC

B SEAT CUSHION



1PCS

C FRONT LEG

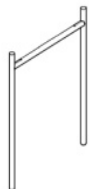

1PCS

D BACK LEG

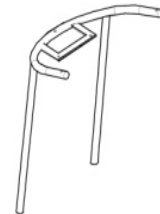

1PCS

E LEG CONNECTING TUBE



2PCS

F FOOTEST



1PCS

### NOTE:

Phillips head screw driver is required in the assembly process; however, manufacturer does not provide this item.

ITEM:183437



## ASSEMBLY INSTRUCTIONS

### ASSEMBLY TIPS:

1. Remove hardware from box and sort by size.
2. Please check to see that all hardware and parts are present prior to start of assembly.
3. Please follow attached instructions in the same sequence as numbered to assure fast & easy assembly.



### WARNING!









1. Don't attempt to repair or modify parts that are broken or defective. Please contact the store immediately.
2. This product is for home use only and not intended for commercial establishments.



ASSEMBLY TIME

5 MINUTES

## HARDWARE IDENTIFICATION

1	ALLEN KEY (6MM )		1PC	6	ALLEN SCREW (M6*25)		4PCS
2	ALLEN KEY (4MM)		1PC	7	ALLEN SCREW (M6*35)		2PCS
3	WRENCH SOCKET (M8)		1PCS	8	ALLEN SCREW (M8*40)		2PCS
4	ALLEN SCREW (M6*10)		2PCS	9	ALLEN SCREW (M6*55)		1PCS
5	ALLEN SCREW (M6*16)		2PCS				

### NOTE:

Phillips head screw driver is required in the assembly process; however, manufacturer does not provide this item.

ITEM: **183437**

# ASSEMBLY INSTRUCTIONS



step1

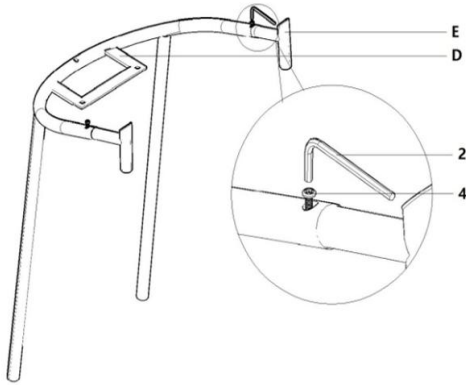

step2

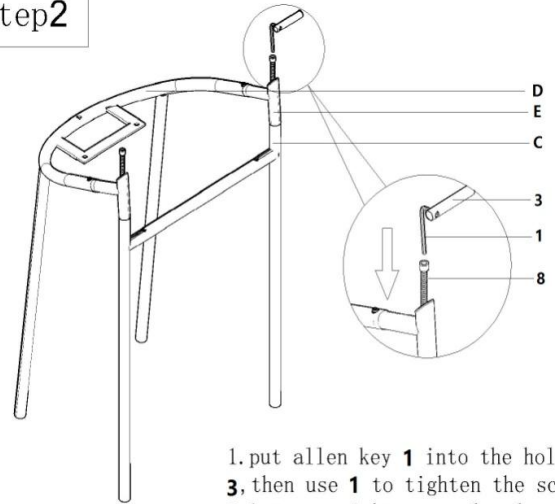

1. put allen key **1** into the hole of **3**, then use **1** to tighten the screw **8**, but not tighten completely.

step3

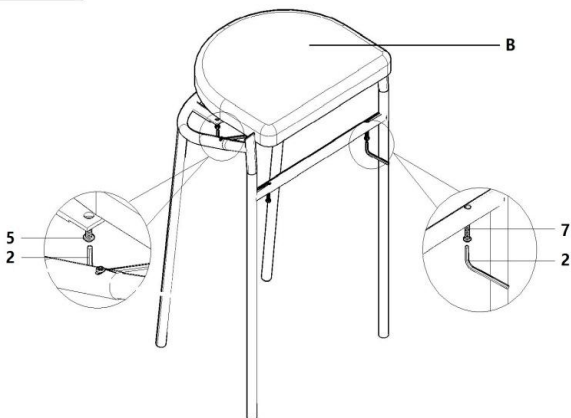

1. put the seat on the frame, use allen key **2** to tighten screw **5** and **7** respectively, but not tighten completely.

step4

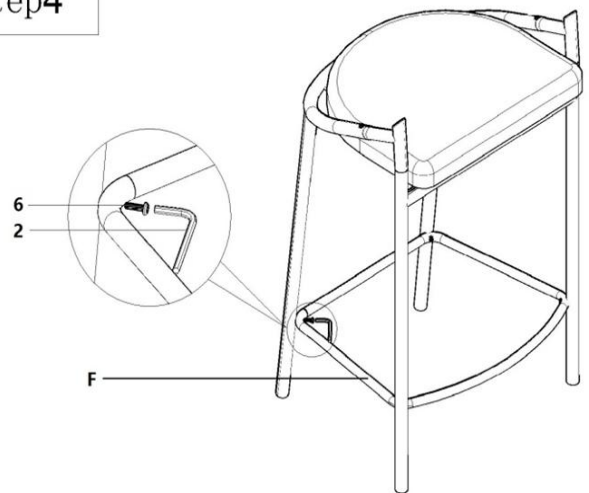

ITEM: **183437**



## ASSEMBLY INSTRUCTIONS

step5

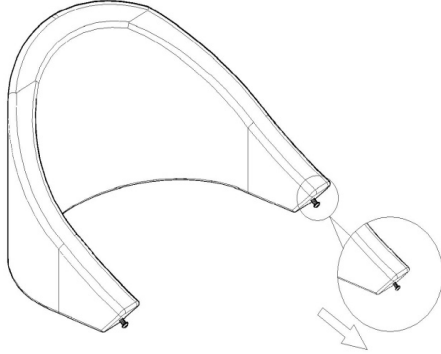

1. loosen the screw out about 10mm.

step6

1. after finishing the step 5, insert the screw head into the hole of the frame.

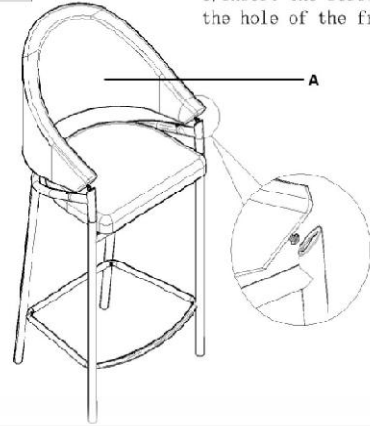

step7

1. Use allen key **2** to tighten screw **9**, then tighten completely.  
2. tighten all the screw **5, 6, 7, 8, 9**, completely in all above steps.

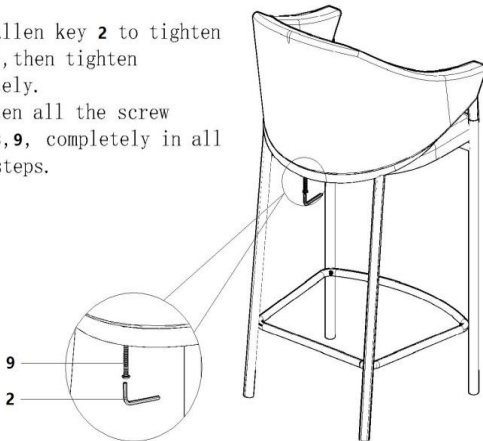

## COMPLETE

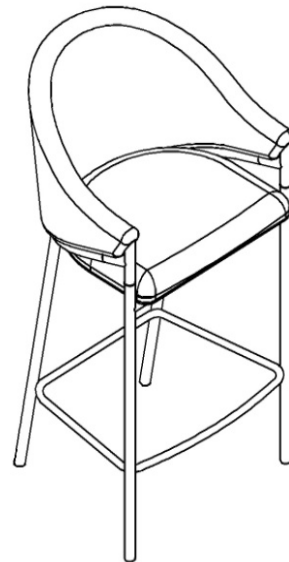

# ITEM: 183437

## ASSEMBLY INSTRUCTIONS

