

ASSEMBLY INSTRUCTIONS
COASTER FINE FURNITURE



Fine Furniture for every stage of life

206430KE (B1-B4)
Eastern King Storage Bed

ITEM: 206430KE (B1-B4)

ASSEMBLY INSTRUCTIONS

ASSEMBLY TIPS:

1. Remove hardware from box and sort by size.
2. Please check to see that all hardware and parts are present prior to start of assembly.
3. Please follow attached instructions in the same sequence as numbered to assure fast & easy assembly.

WARNING!



1. Don't attempt to repair or modify parts that are broken or defective. Please contact the store immediately.
2. This product is for home use only and not intended for commercial establishments.

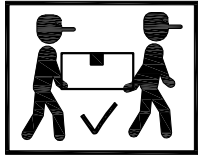





ASSEMBLY TIME





20 MINUTES

PARTS IDENTIFICATION

B1 (BOX 1)

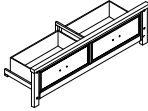
A	HEADBOARD PANEL		1PC	C	RIGHT HEADBOARD LEG		1PC
B	LEFT HEADBOARD LEG		1PC	D	HEADBOARD BOTTOM RAIL		1PC

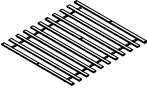

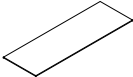

B2 (BOX 2)

E	STORAGE FOOTBOARD		1PC	H	CENTER RAIL SUPPORT WITH LEVELER		2PCS
F	ROLL SLAT (11PCS)		1SET	I	BED SLAT SUPPORT WITH LEVELER		6PCS
G	CONCEAL PANEL		5PCS				

B3 (BOX 3)

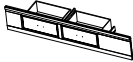
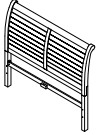
J	RIGHT STORAGE SIDE RAIL		1PC	K	STORAGE SUPPORT LEG WITH LEVELER		3PCS
---	-------------------------	---	-----	---	----------------------------------	---	------

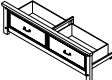
B4 (BOX 4)

M	LEFT STORAGE SIDE RAIL		1PC	HB	206430KE(B1) FROM BOX 1 HEADBOARD COMPLETE		1PC
N	STORAGE SUPPORT LEG WITH LEVELER		3PCS	E	206430KE(B2) FROM BOX 2 STORAGE FOOTBOARD		1PC
P	CENTER RAIL		1PC				

ITEM: 206430KE (B1-B4)

ASSEMBLY INSTRUCTIONS

ASSEMBLY TIPS:

1. Remove hardware from box and sort by size.
2. Please check to see that all hardware and parts are present prior to start of assembly.
3. Please follow attached instructions in the same sequence as numbered to assure fast & easy assembly.







WARNING!



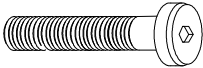

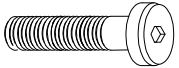
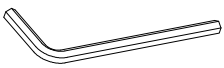

1. Don't attempt to repair or modify parts that are broken or defective. Please contact the store immediately.
2. This product is for home use only and not intended for commercial establishments.

HARDWARE IDENTIFICATION

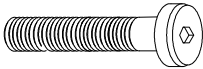
Z - B1 (BOX 1)-HARDWARE PACK IS LOCATED IN 206430KE (B1)

1	LONG BOLT (5/16" x 45mm - BLK)		6PCS	4	FLAT WASHER (5/16" x 19 x 1.5mm - BLK)		10PCS
2	SHORT BOLT (5/16" x 32mm - BLK)		4PCS	5	ALLEN WRENCH (4MM - BLK)		1PC
3	LOCK WASHER (5/16" - BLK)		10PCS				

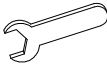
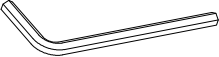
Z - B4 (BOX 4)- HARDWARE PACK IS LOCATED IN 206430KE (B4)

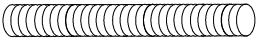
6	BOLT (1/4" x 32mm - BLK)		5PCS	11	U-SQUARE WASHER (25 x 15 x 2mm - RBW)		8PCS
7	LOCK WASHER (1/4" - BLK)		5PCS	12	HEX NUT (5/16" x 17mm - RBW)		8PCS
8	FLAT WASHER (1/4" x 19 x 1.5mm - BLK)		5PCS	13	WRENCH (13MM - RBW)		1PC
9	ALLEN WRENCH (4MM - BLK)		1PC	14	FLAT HEAD SCREW (4 x 32mm - RBW)		12PCS
10	THREADED BOLT (5/16" x 75mm - RBW)		8PCS				

NOTE:
Phillips head screw driver is required in the assembly process; however, manufacturer does not provide this item.

ITEM: 206430KE (B1-B4)

ASSEMBLY INSTRUCTIONS

STEP 1

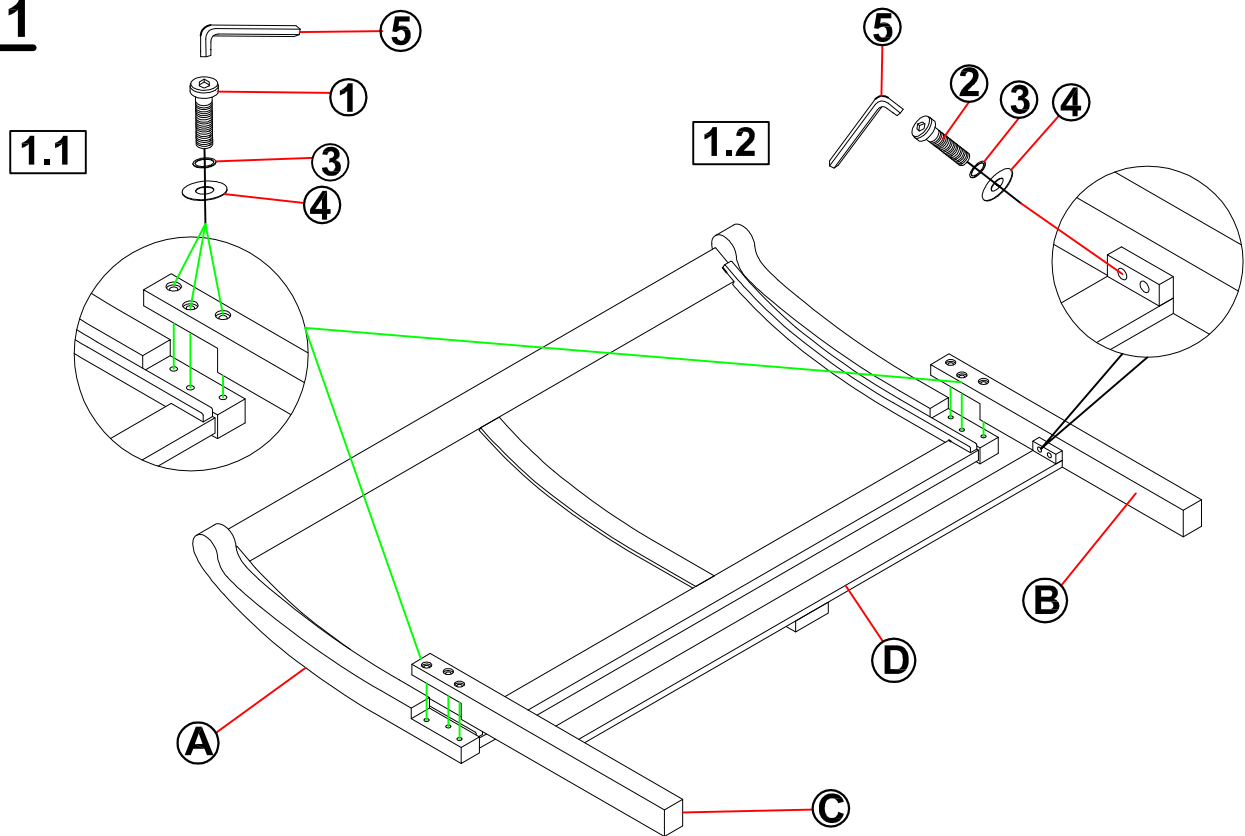

STEP 2

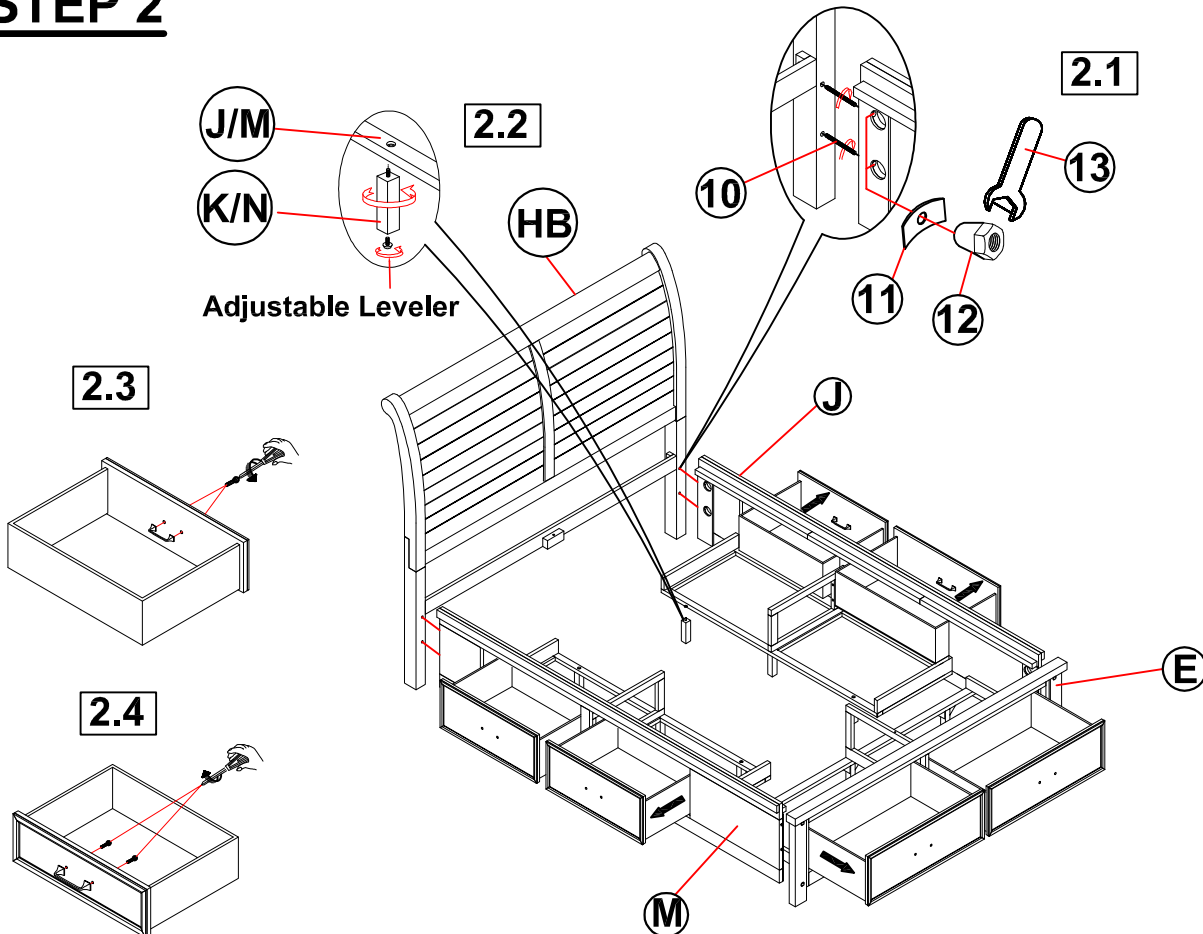

ITEM: 206430KE (B1-B4)

ASSEMBLY INSTRUCTIONS

STEP 3

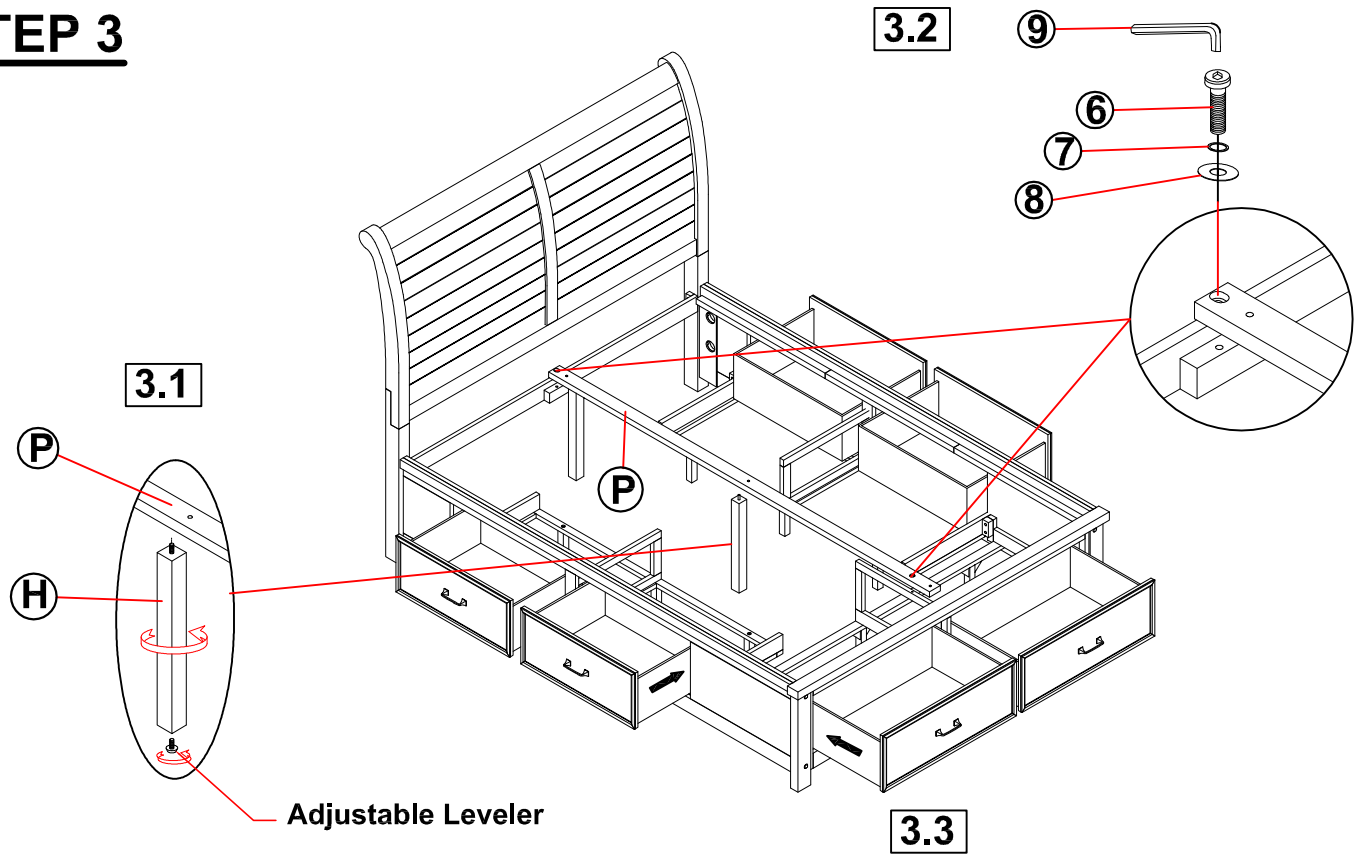

STEP 4

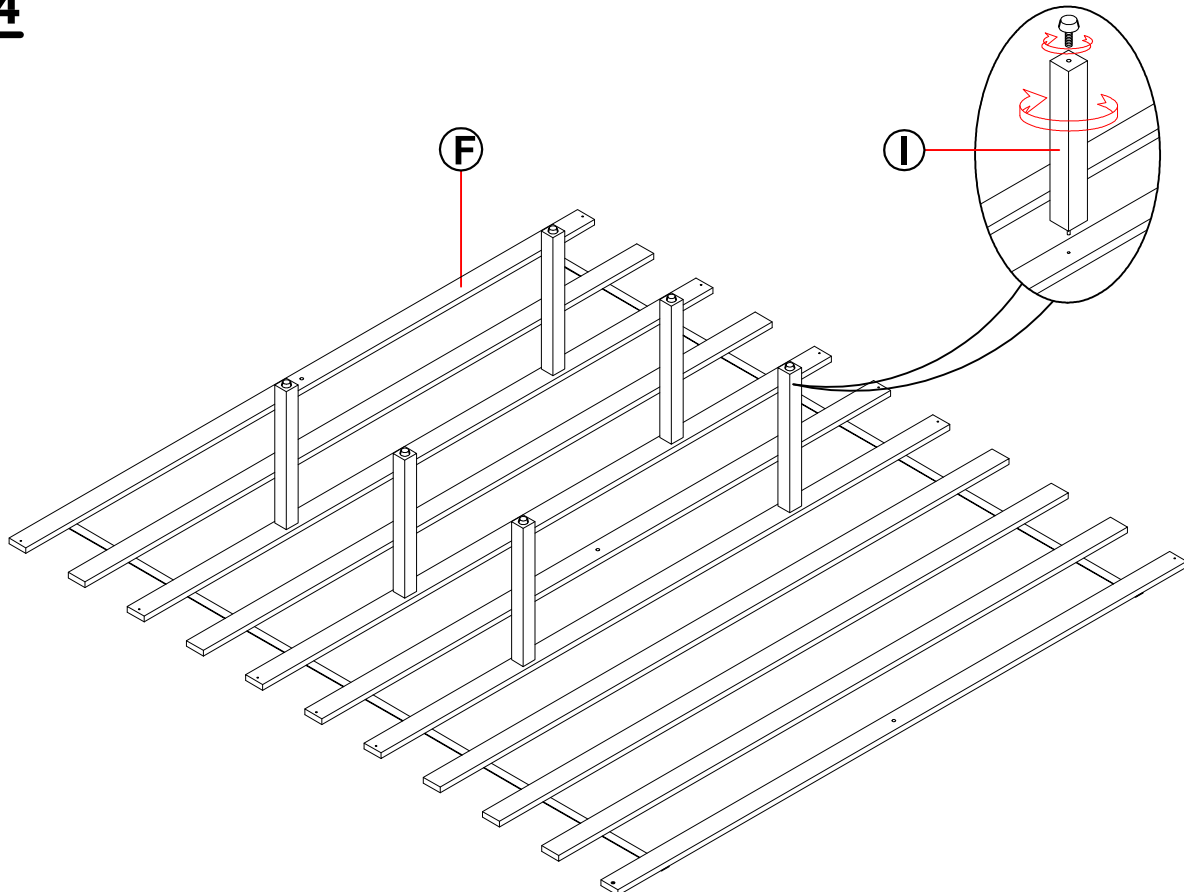

ITEM: 206430KE (B1-B4)

ASSEMBLY INSTRUCTIONS

STEP 5

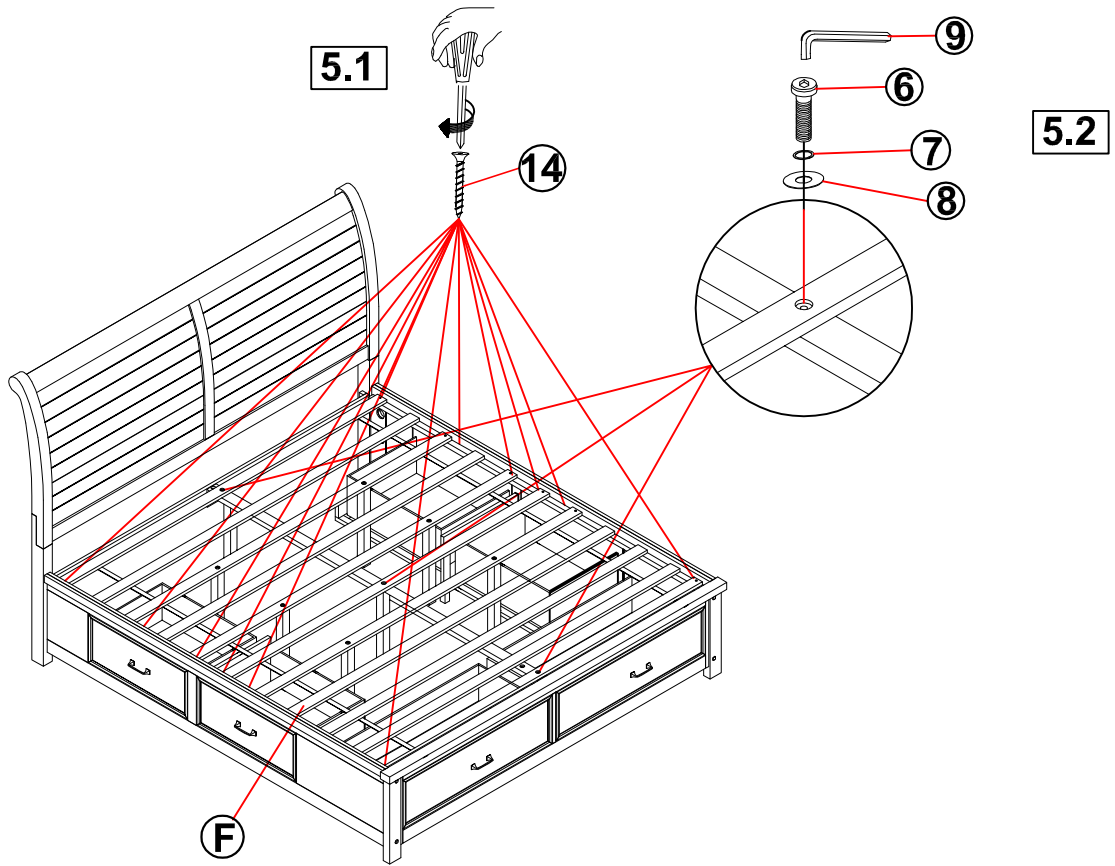

STEP 6

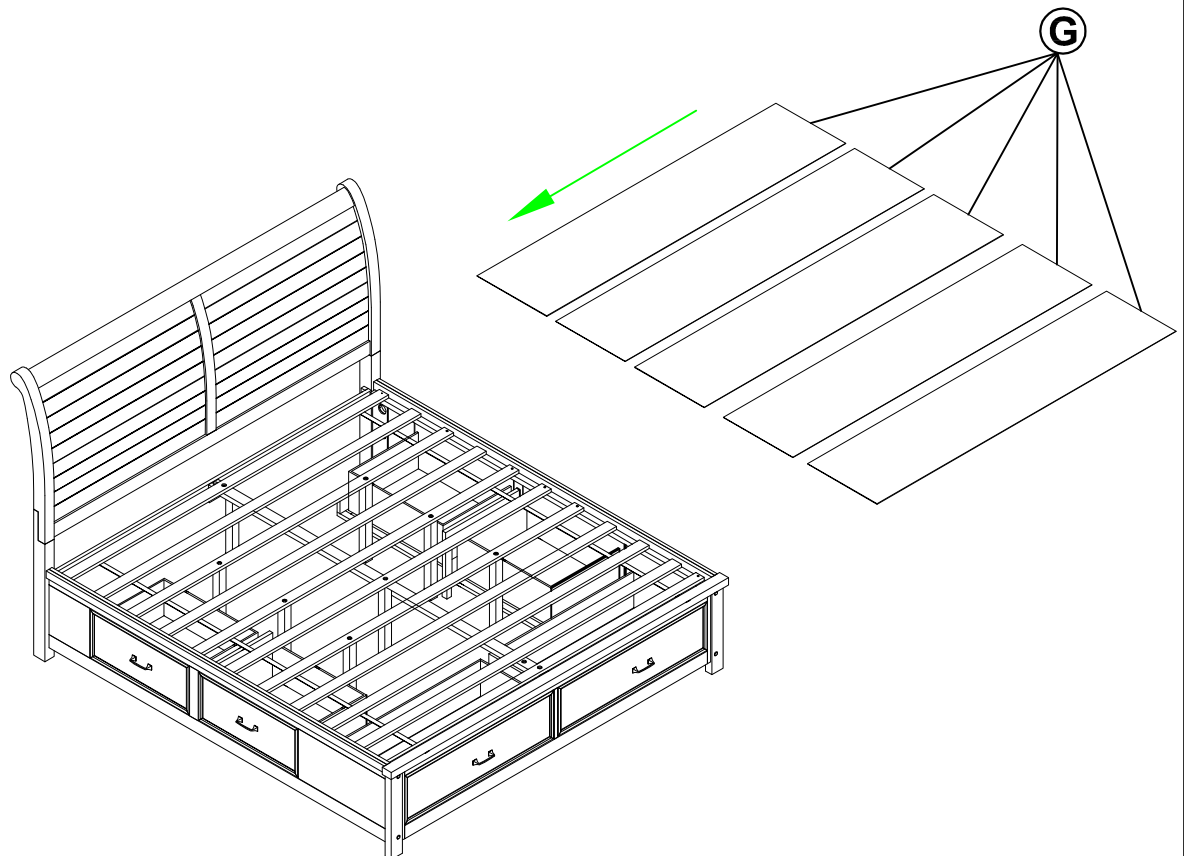

ITEM: **206430KE (B1-B4)**

ASSEMBLY INSTRUCTIONS



STEP 7
COMPLETE

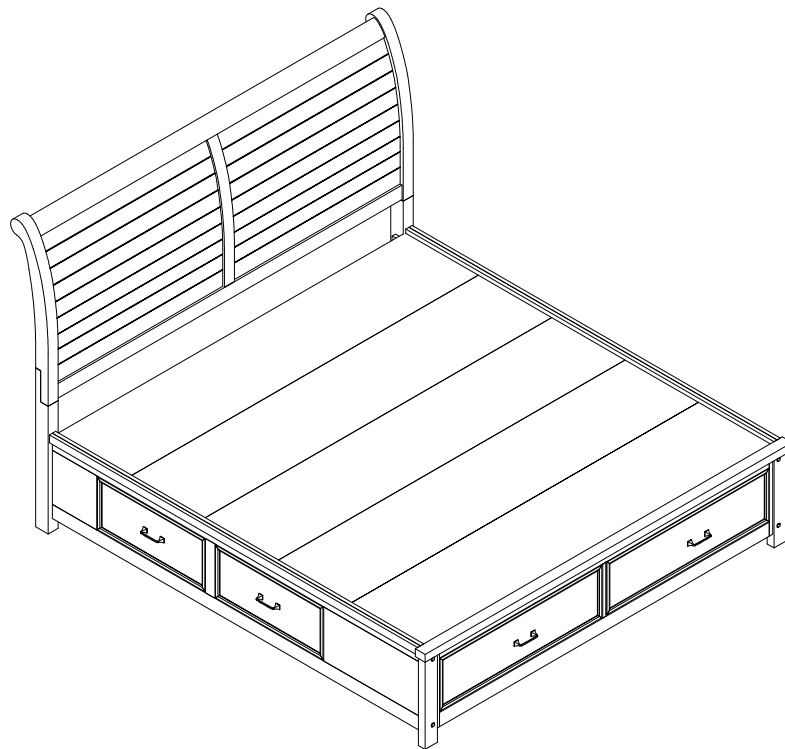

ITEM: 206430KE (B1-B4)

INNER SIZE OF DRAWER 1 : 33.9" x 15.9" x 7.4"
INNER SIZE OF DRAWER 2 : 22" x 15.9" x 7.4"

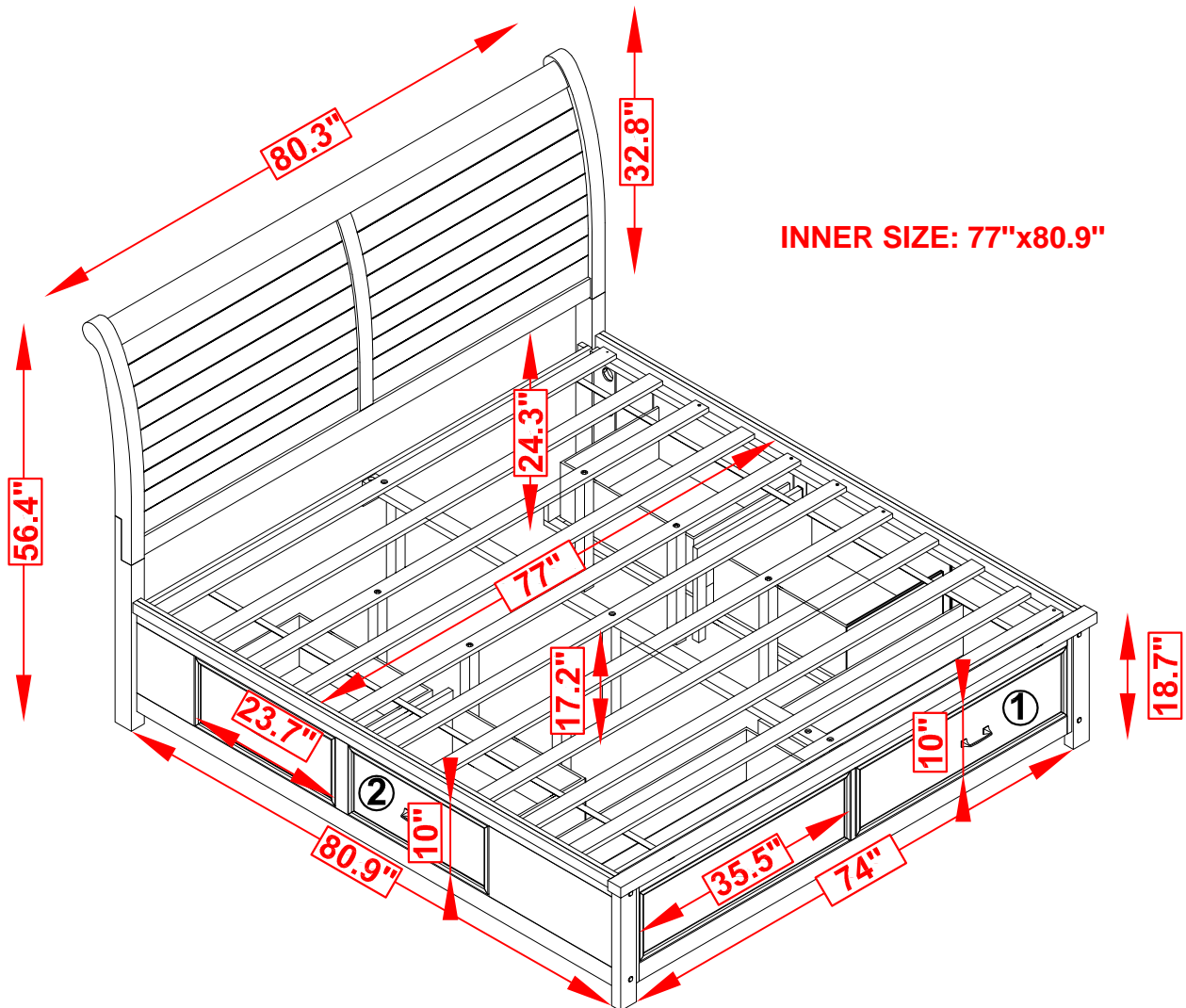

Note : Dimension tolerance $\pm 5\%$