

ASSEMBLY INSTRUCTIONS
COASTER FINE FURNITURE



Fine Furniture for every stage of life

206430Q (B1-B4)
Queen Storage Bed

ITEM: 206430Q (B1-B4)

ASSEMBLY INSTRUCTIONS

ASSEMBLY TIPS:

1. Remove hardware from box and sort by size.
2. Please check to see that all hardware and parts are present prior to start of assembly.
3. Please follow attached instructions in the same sequence as numbered to assure fast & easy assembly.

WARNING!



1. Don't attempt to repair or modify parts that are broken or defective. Please contact the store immediately.
2. This product is for home use only and not intended for commercial establishments.

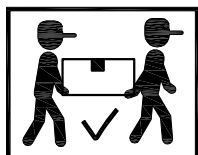





ASSEMBLY TIME

20 MINUTES

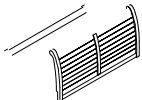
PARTS IDENTIFICATION



B1 (BOX 1)

| | | | |
|---|-----------------------|--|-----|
| A | HEADBOARD PANEL |  | 1PC |
| B | LEFT HEADBOARD LEG |  | 1PC |

| | | | |
|---|--------------------------|--|-----|
| C | RIGHT HEADBOARD LEG |  | 1PC |
| D | HEADBOARD BOTTOM RAIL |  | 1PC |

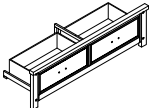
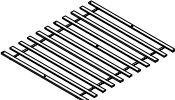
B2 (BOX 2)

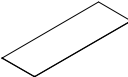
| | | | |
|---|-----------------------|---|-------|
| E | STORAGE FOOTBOARD |  | 1PC |
| F | ROLL SLAT (11 PCS) |  | 1 SET |



| | | | |
|---|-------------------------------------|---|------|
| G | CONCEAL PANEL |  | 5PCS |
| H | CENTER RAIL SUPPORT WITH LEVELER |  | 2PCS |

B3 (BOX 3)

| | | | |
|---|----------------------------|---|-----|
| I | RIGHT STORAGE SIDE RAIL |  | 1PC |
|---|----------------------------|---|-----|

| | | | |
|---|-------------------------------------|---|------|
| J | STORAGE SUPPORT LEG WITH LEVELER |  | 3PCS |
|---|-------------------------------------|---|------|

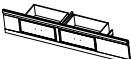
B4 (BOX 4)

| | | | |
|---|-------------------------------------|---|------|
| L | LEFT STORAGE SIDE RAIL |  | 1PC |
| M | STORAGE SUPPORT LEG WITH LEVELER |  | 3PCS |
| O | CENTER RAIL |  | 1PC |

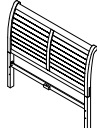
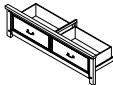
| | | | |
|----|---|---|-----|
| HB | 206430KE(B1) FROM BOX 1 HEADBOARD COMPLETE |  | 1PC |
| E | 206430KE(B2) FROM BOX 2 STORAGE FOOTBOARD |  | 1PC |

ITEM: 206430Q (B1-B4)

ASSEMBLY INSTRUCTIONS

ASSEMBLY TIPS:

1. Remove hardware from box and sort by size.
2. Please check to see that all hardware and parts are present prior to start of assembly.
3. Please follow attached instructions in the same sequence as numbered to assure fast & easy assembly.







WARNING!



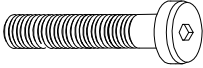

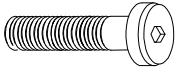

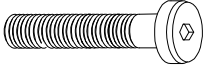

1. Don't attempt to repair or modify parts that are broken or defective. Please contact the store immediately.
2. This product is for home use only and not intended for commercial establishments.

HARDWARE IDENTIFICATION

Z - B1 (BOX 1)-HARDWARE PACK IS LOCATED IN 206430Q (B1)

| | | | | | | | |
|---|---|---|-------|---|--|--|-------|
| 1 | LONG BOLT (5/16" x 45mm - BLK) |  | 6PCS | 4 | FLAT WASHER (5/16" x 19 x 1.5mm - BLK) |  | 10PCS |
| 2 | SHORT BOLT (5/16" x 32mm - BLK) |  | 4PCS | 5 | ALLEN WRENCH (4MM - BLK) |  | 1PC |
| 3 | LOCK WASHER (5/16" - BLK) |  | 10PCS | | | | |

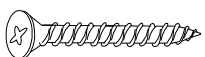
Z - B4 (BOX 4)- HARDWARE PACK IS LOCATED IN 206430Q (B4)

| | | | | | | | |
|----|---|---|------|----|---|---|------|
| 6 | BOLT (1/4" x 32mm - BLK) |  | 5PCS | 11 | U-SQUARE WASHER (25 x 15 x 2mm - RBW) |  | 8PCS |
| 7 | LOCK WASHER (1/4" - BLK) |  | 5PCS | 12 | HEX NUT (5/16" x 17mm - RBW) |  | 8PCS |
| 8 | FLAT WASHER (1/4" x 19 x 1.5mm - BLK) |  | 5PCS | 13 | WRENCH (13MM - RBW) |  | 1PC |
| 9 | ALLEN WRENCH (4MM - BLK) |  | 1PC | 14 | FLAT HEAD SCREW (4 x 32mm - RBW) |  | 6PCS |
| 10 | THREADED BOLT (5/16" x 75mm - RBW) |  | 8PCS | | | | |

NOTE:
Phillips head screw driver is required in the assembly process; however, manufacturer does not provide this item.

ITEM: 206430Q (B1-B4)

ASSEMBLY INSTRUCTIONS

STEP 1

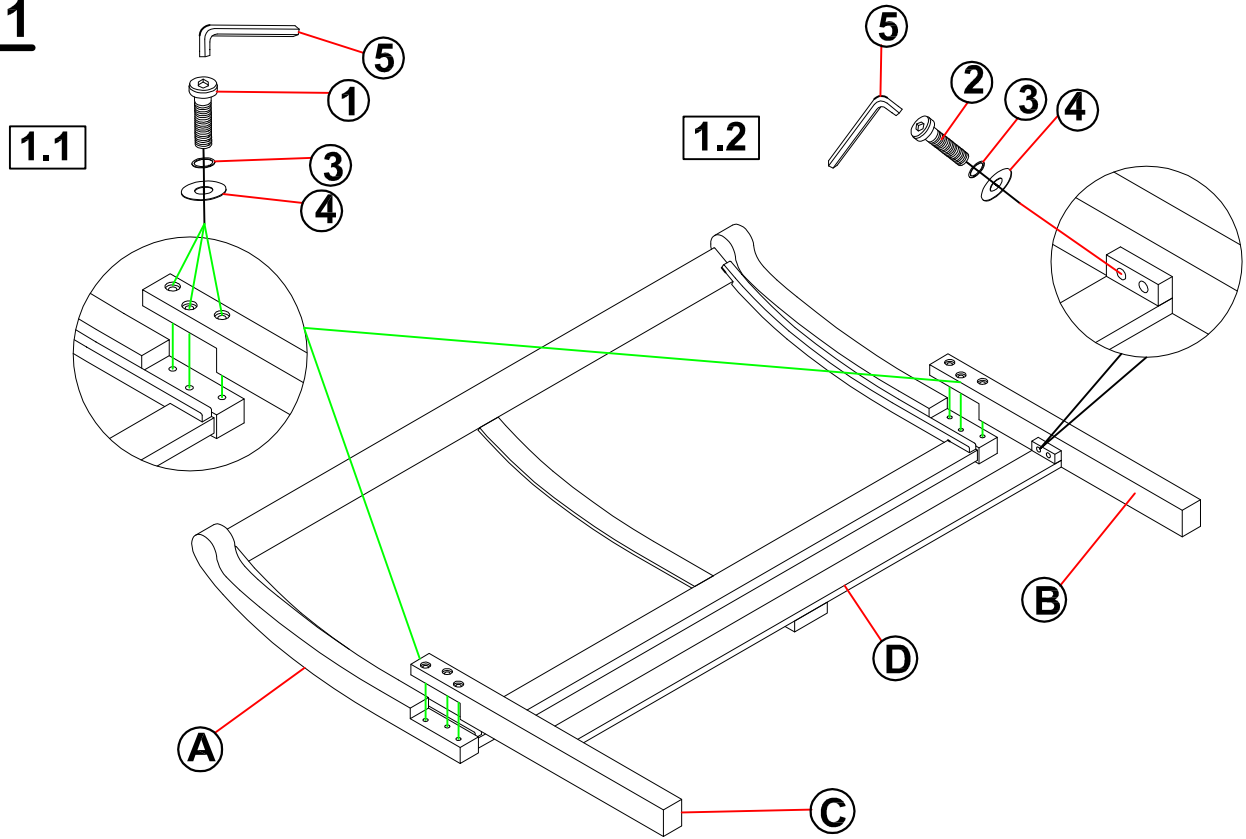

STEP 2

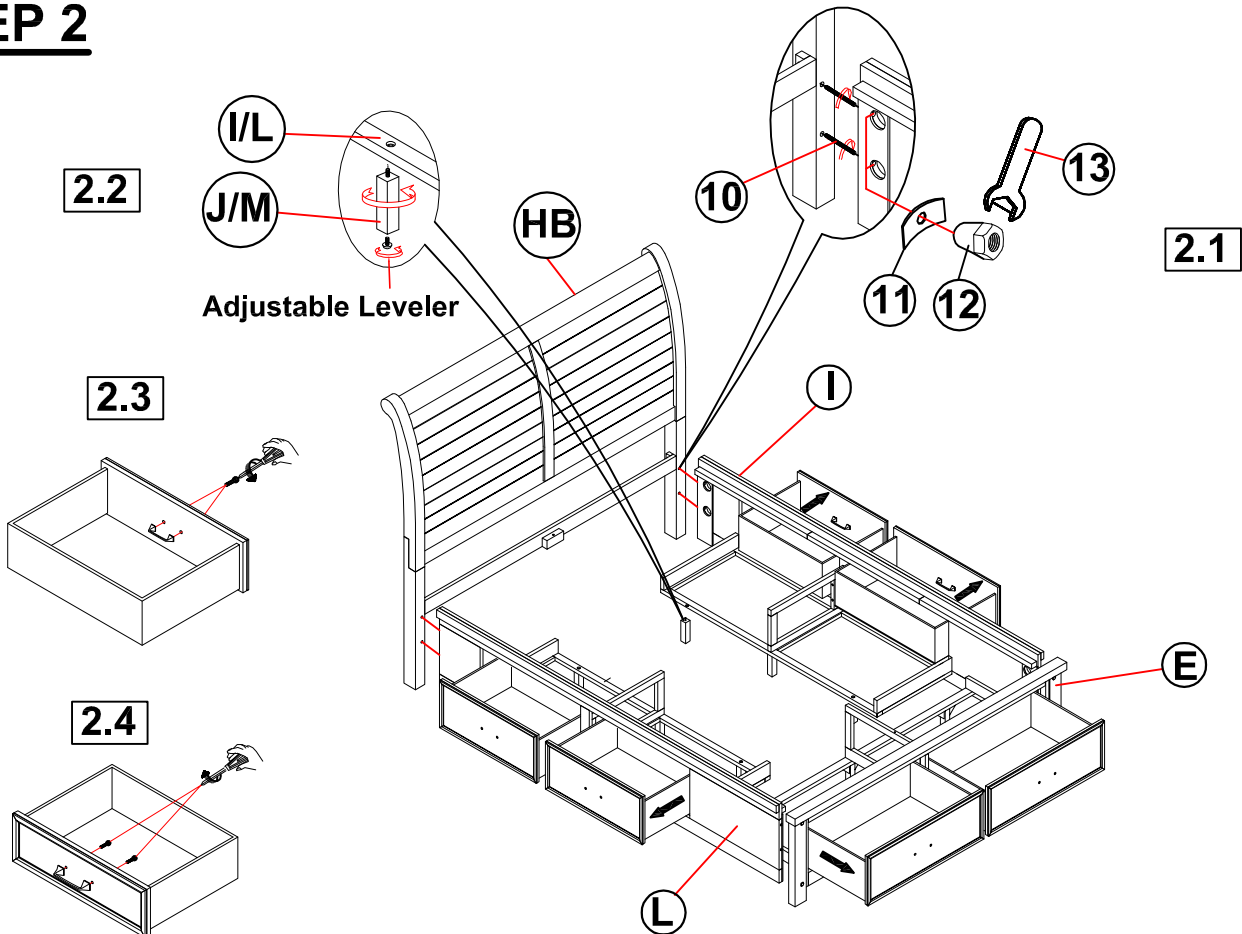

ITEM: 206430Q (B1-B4)

ASSEMBLY INSTRUCTIONS

STEP 3

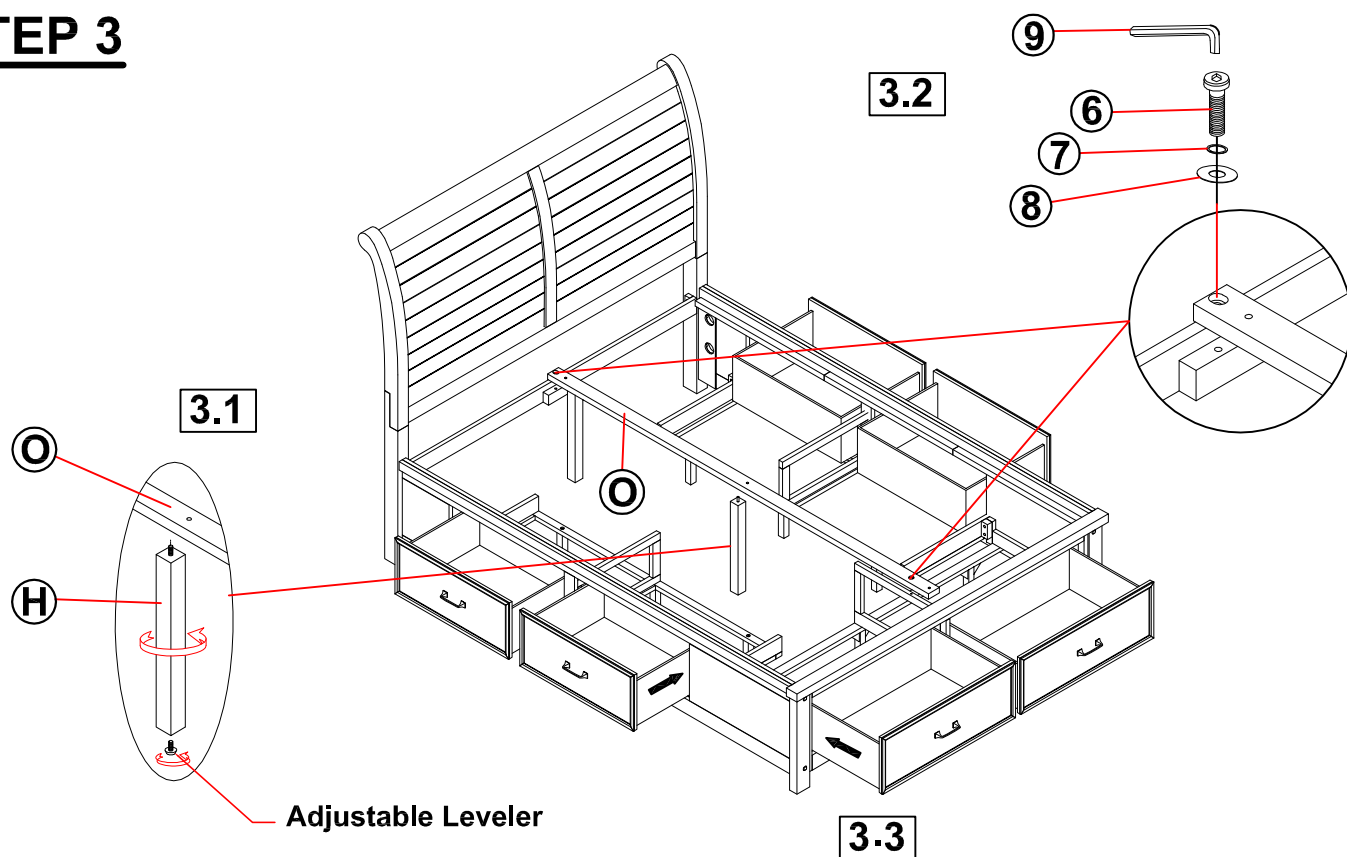

STEP 4

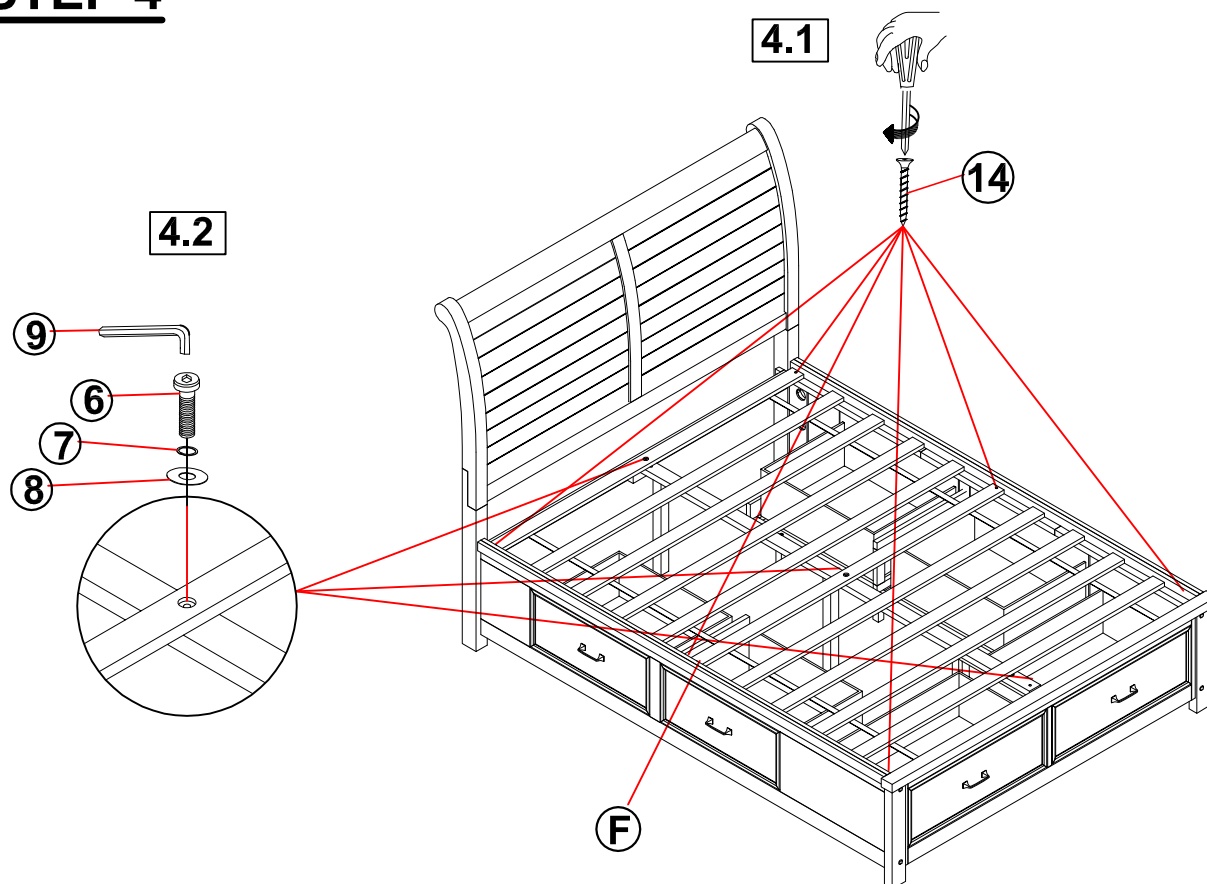

ITEM: **206430Q (B1-B4)**

ASSEMBLY INSTRUCTIONS



STEP 5

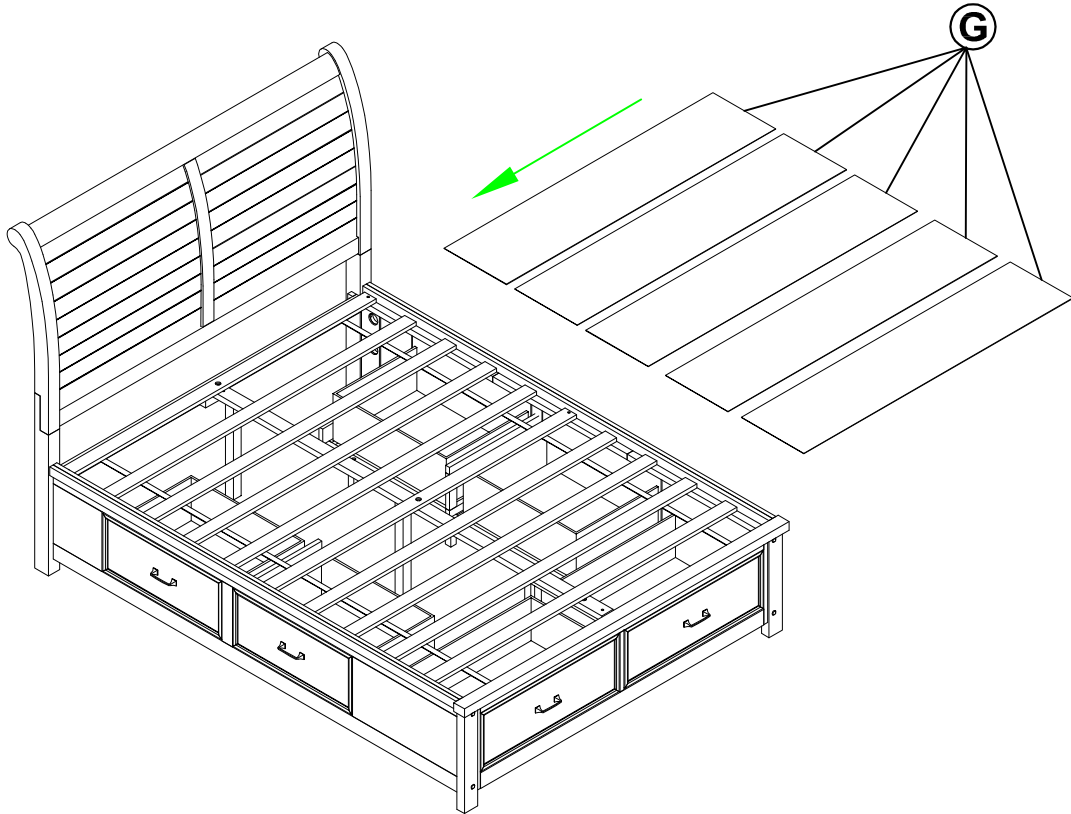

STEP 6
COMPLETE

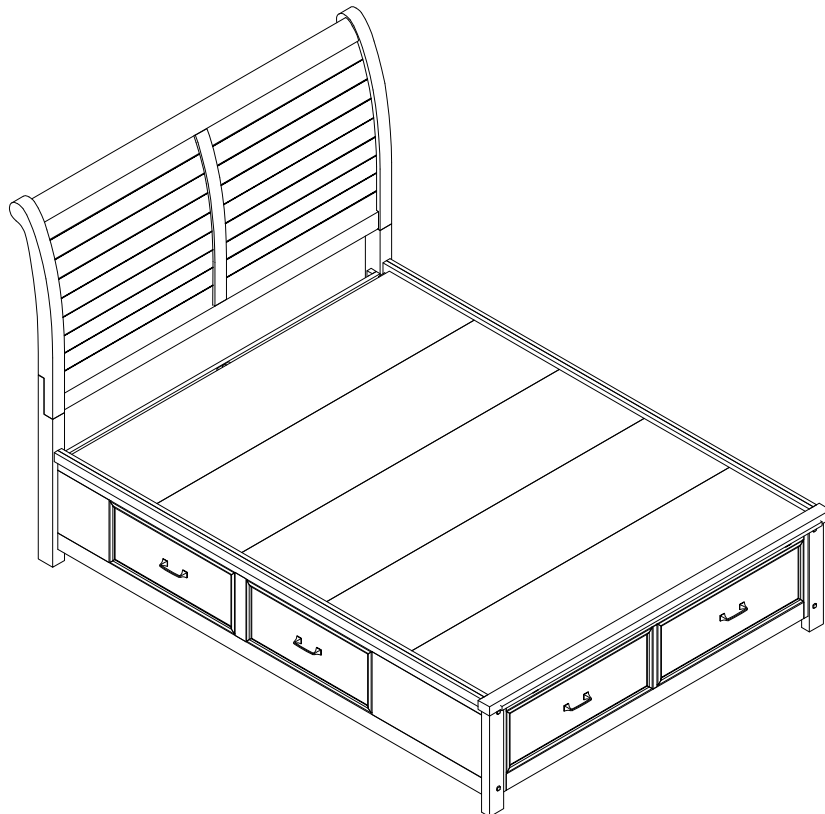

ITEM:206430Q (B1-B4)

COASTER
FINE FURNITURE

INNER SIZE OF DRAWER 1 : 25.9" x 15.9" x 7.4"

INNER SIZE OF DRAWER 2 : 22" x 15.9" x 7.4"

INNER SIZE: 60.7"x80.9"

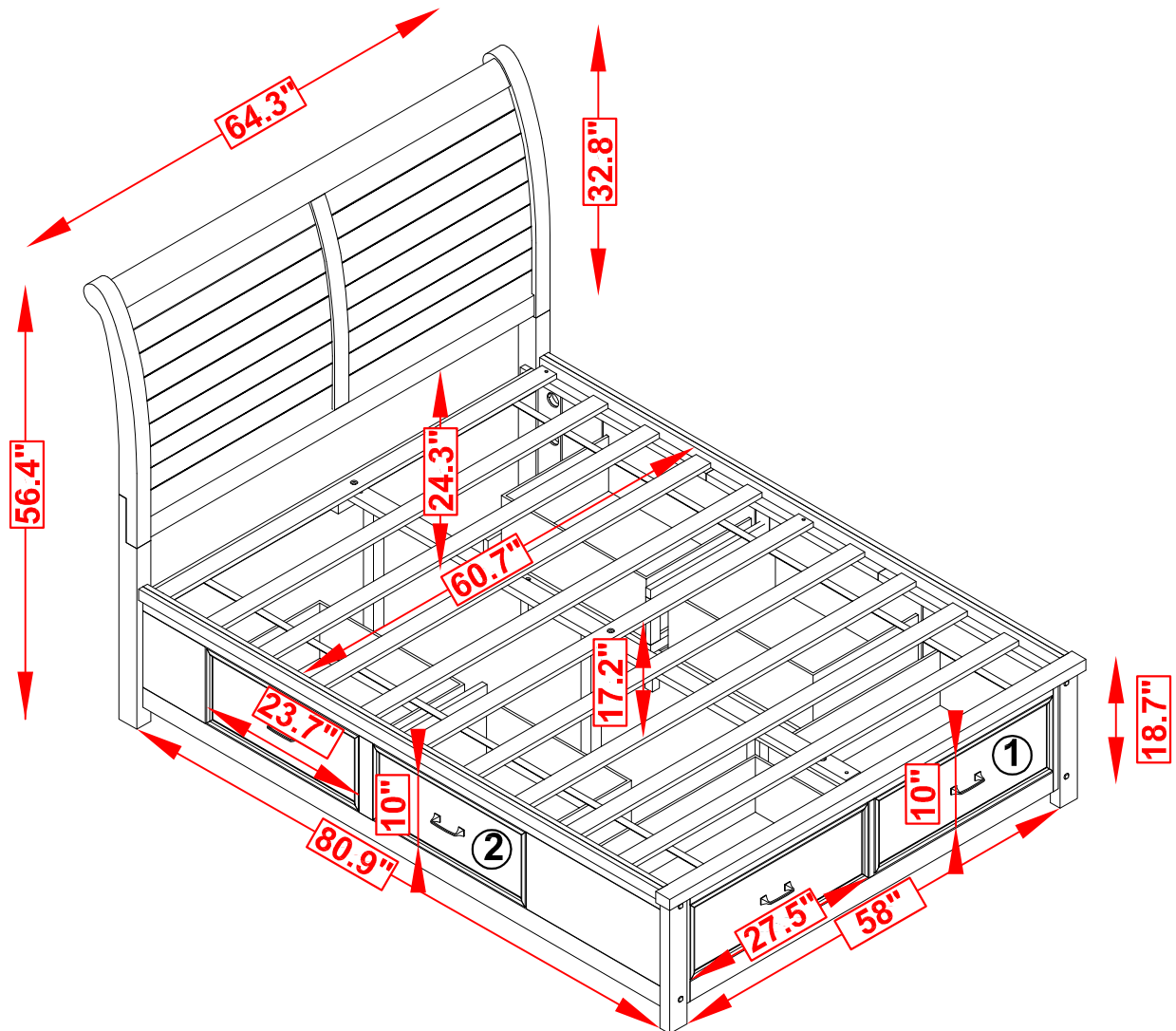

Note : Dimension tolerance $\pm 5\%$