

ASSEMBLY INSTRUCTIONS
COASTER FINE FURNITURE



Fine Furniture for every stage of life

991038
Writing Desk

ITEM: **991038**



ASSEMBLY INSTRUCTIONS

ASSEMBLY TIPS:

1. Remove hardware from box and sort by size.
2. Please check to see that all hardware and parts are present prior to start of assembly.
3. Please follow attached instructions in the same sequence as numbered to assure fast & easy assembly.



WARNING!

1. Don't attempt to repair or modify parts that are broken or defective. Please contact the store immediately.
2. This product is for home use only and not intended for commercial establishments.



ASSEMBLY TIME

15 MINUTES

PARTS IDENTIFICATION

A TOP

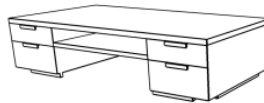

1PC

B LEG



4PCS

HARDWARE IDENTIFICATION

1 BOLT
(M8 x 20mm - BLK)



8PCS

2 FLAT WASHER
(M10 x 16mm - BLK)



8PCS

3 ALLEN WRENCH
(5mm - BLK)



1PC

ITEM: **991038**

ASSEMBLY INSTRUCTIONS
STEP 1

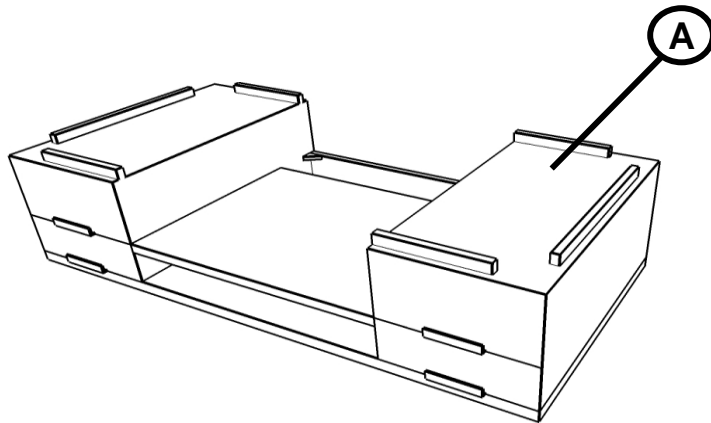

STEP 2

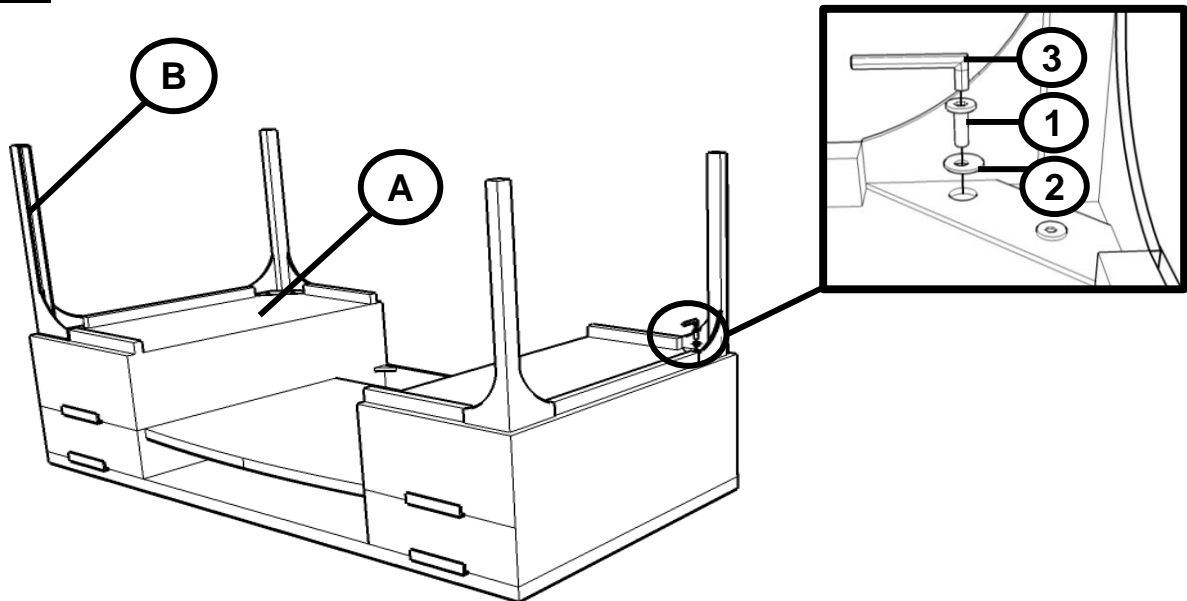

STEP 3
COMPLETE

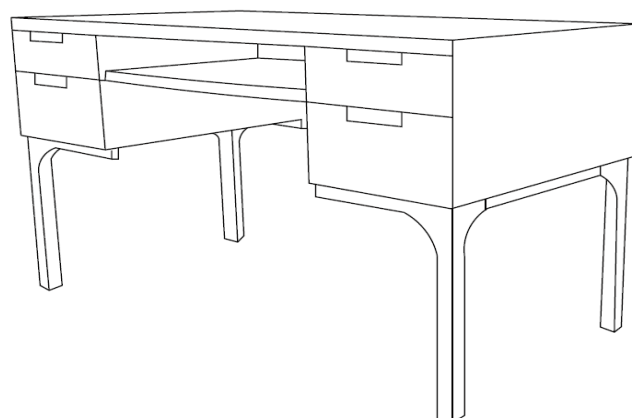

ITEM: 991038

COASTER
FINE FURNITURE

INNER SIZE OF DRAWER (A) : 10.5"X14.5"X2.5"
INNER SIZE OF DRAWER (B) : 10.5"X14.5"X4.25"

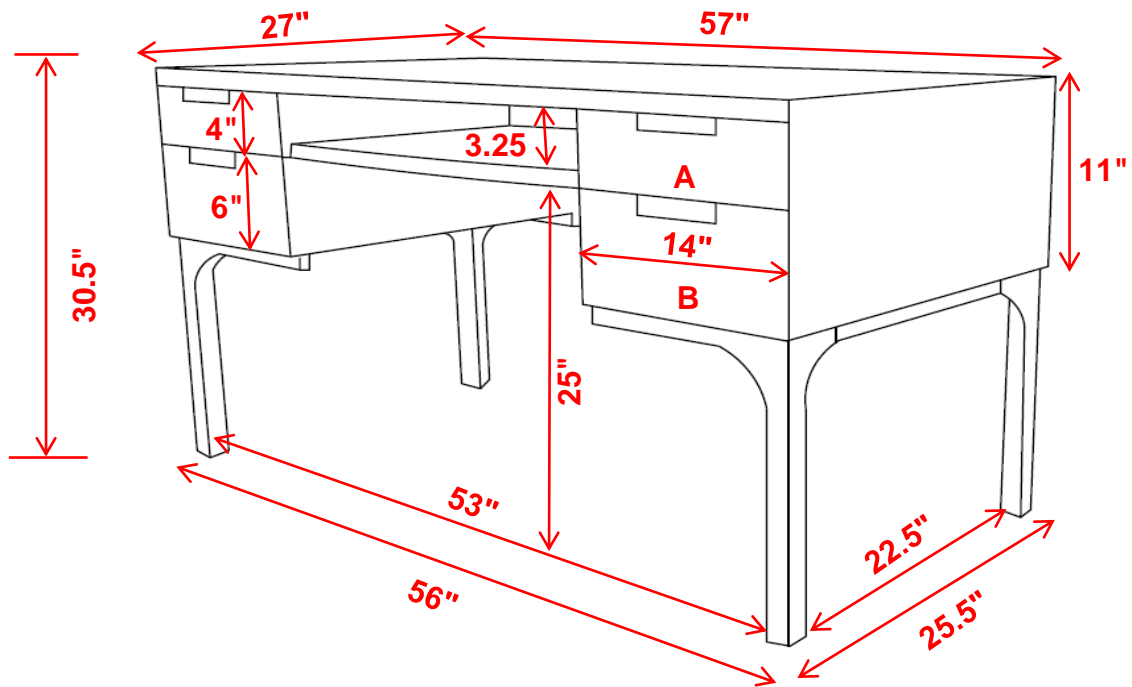

Note : Dimension tolerance $\pm 5\%$